

01-03

Transparent Factory

Schneider Electric

Transparent Factory®

The Future of Automation

Catalogue
January

2003

Transparent
Factory
Real Time

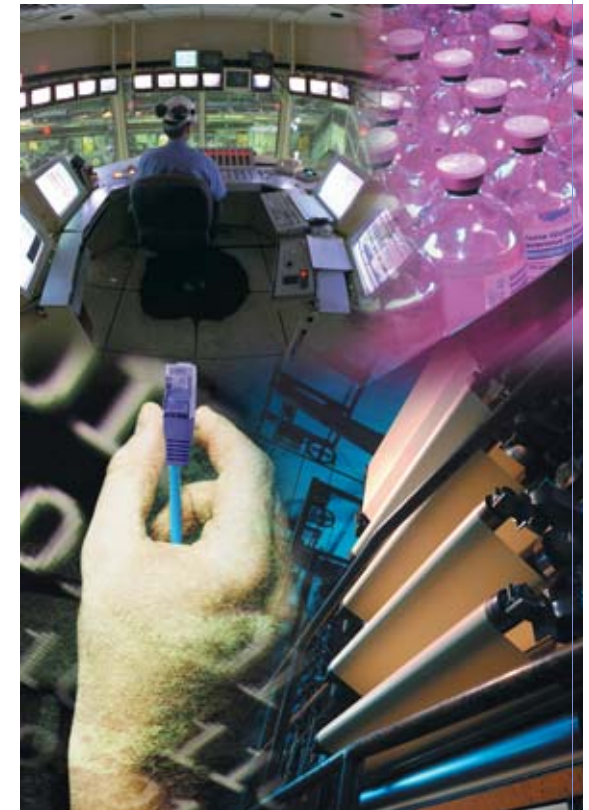

<http://www.schneider-electric.com>

Schneider Electric Industries SA
AUTC201108140EN

January 2003



Merlin Gerin
Modicon
Square D
Telemecanique

Schneider
 **Electric**
Building a New Electric World

Transparent Factory

- Introduction page 2
- Product table page 6
- Selection guides pages 8 to 25**
 - Quantum automation platform selection guide page 8
 - Premium automation platform selection guide page 10
 - Momentum automation platform selection guide page 14
 - Micro automation platform selection guide page 16
 - ConneXium industrial Ethernet page 18
 - Transparent Factory page 24
- Architecture page 26
 - Overview page 26
 - Ethernet TCP/IP standard services page 30
 - Ethernet TCP/IP enhanced service page 38
 - Network systems page 46
- Communications page 52
 - Quantum page 52
 - Premium page 54
 - Momentum page 57
 - Micro page 59
 - ConneXium page 60
 - Schneider Electric Ethernet page 65
- Customer reference notes page 70

Services

- Network certifications services page 98
- Community regulations and protective treatment page 101
- Automation product certifications page 102
- Schneider Electric worldwide page 104

Schneider Electric's Transparent Factory is an *open automation framework* based on *internet technologies* that provides *seamless communication* between plant floor and business systems.

Q: "Why do I need Transparent Factory?"

A: With Transparent Factory you can:

- *Use* a common Ethernet infrastructure from manufacturing to MES.
- *Gain* competitive advantage through proven real-time performance.
- *Reduce* downtime through Web-based diagnostics.
- *Create* secure inter-plant communication worldwide.
- *Cut* training cost with everyday tools.
- *Contain* cost through open standards.

Innovation network



**Computerworld
Smithsonian
Award Winner**

This catalog is specifically designed to introduce you to Transparent Factory a world where products are compatible, interoperable and easy to maintain.

Where performance is high and overall costs are low. The detailed information inside includes not only individual product specifications but selection guides, and sample architectures that demonstrate how Transparent Factory automation solutions harness the power of the Internet to optimize productivity in virtually any manufacturing application.



Over thirty years ago, Schneider Electric revolutionized manufacturing with the introduction of the first PLC, the Modicon 084.

Continued dedication to customer focused innovation once again places Schneider Electric at the forefront of the current revolution the Internet. With a clear vision of the future, Schneider Electric introduced Transparent Factory automation solutions and became the first automation supplier to bring Web-based technologies to the factory floor.

By exposing real-time information at the source, Transparent Factory eliminates proprietary barriers, allowing business systems to access real-time production data not just from anywhere on the plant floor, but from anywhere in the world.

Transparent Factory technology from Schneider Electric delivers seamless connectivity to the "multi vendor" environment of today's factory floor.



Quantum NOE Module



Premium ETY module



ConneXium 499 NOS 171 00



Momentum M1E

True standards

Ethernet

It's fast, cost effective and reliable. Designed for the factory floor, Industrial Ethernet has helped construct open networks that no longer face bandwidth restrictions, and bring the benefits of IP to the factory floor.

TCP/IP

TCP/IP is the Internet standard as well as the global networking standard for all computing needs. Its optimal flexibility allows it to act as a carrier for HTTP, Modbus, FTP and many other protocols.

Modbus

The industry's serial de facto standard since 1979, Modbus continues to enable millions of automation devices to communicate. Today, support for the simple and elegant structure of Modbus continues to grow. The Internet community has adopted Modbus by giving it a reserved port on the TCP/IP stack. Users can download the Modbus/TCP protocol specifications and source code free from Schneider Electric's Industrial Automation Business web site. (See URL below.)

Transparent Factory

When a versatile, scaleable physical network (Ethernet) is combined with a vendor-neutral data representation (Modbus), the result is a truly open, accessible network. A network so powerful it can exchange process data right down to the sensor level. Schneider Electric continues to pioneer open standards with the world's first automation embedded web server. New enhancements to the Transparent Factory platform provide critical new services including real-time publish/subscribe, faulty Device replacement, network management and resource monitoring.

www.schneiderautomation.com



Transparent Factory

Accessing information in the Transparent Factory

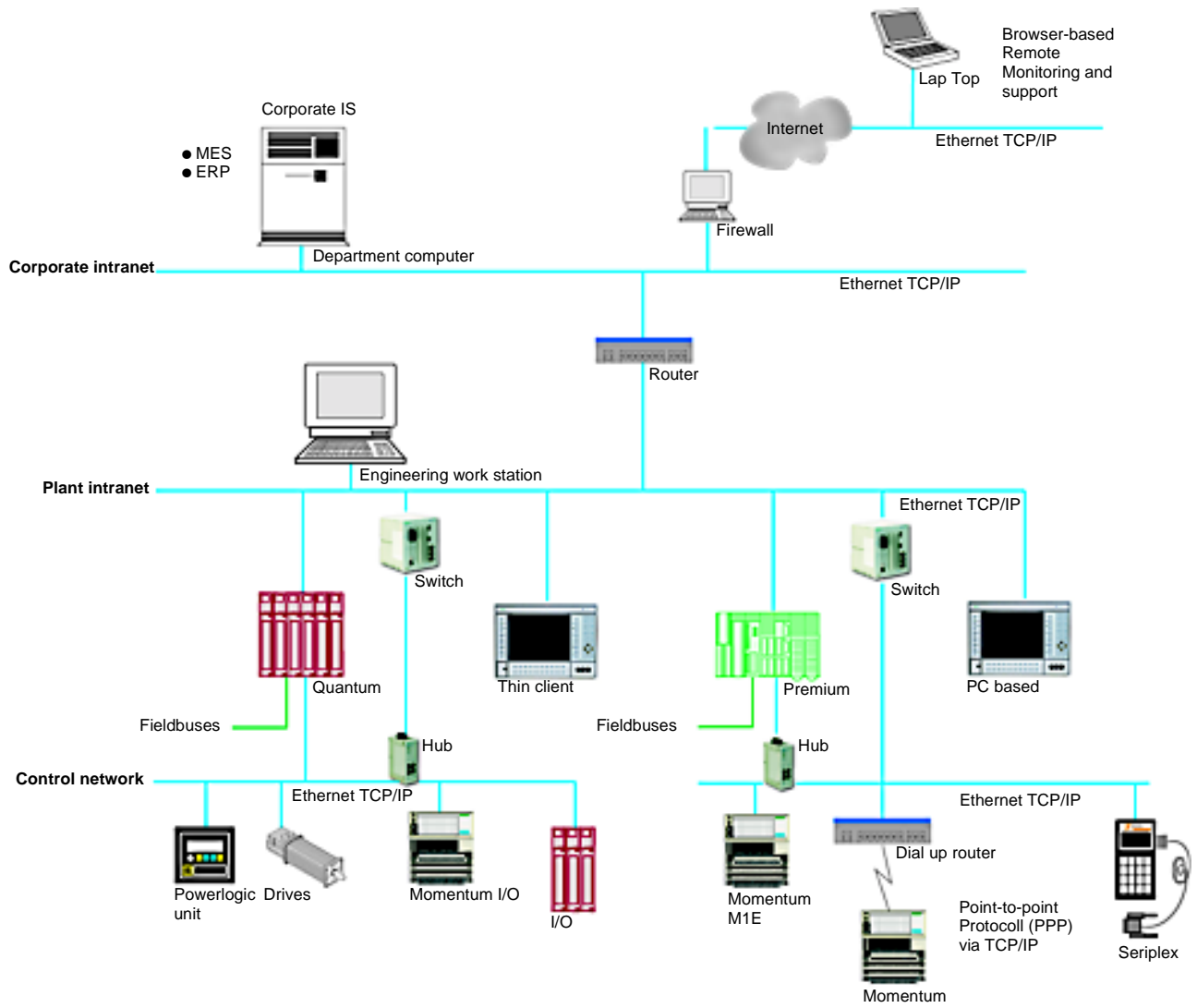

Transparent Factory

Product table

Model	170 NOE 771 00	170 NOE 771 10	170 NOE 771 01	170 NOE 771 11	TSX ETY 110	TSX ETY 110WS	TSX ETY 210
Description	Ethernet 10/100	FactoryCast	Ethernet 10/100	FactoryCast	Ethernet 10	Ethernet 10 FactoryCast	Ethernet 10
Modbus client/server							
Xway client/server							
Embedded web server							
User web pages							
I/O scanner							
FDR client							
FDR server							
SNMP							
Publish/subscribe							
Bandwidth monitor							
Hot swap							
Hot standby			Available in future release	Available in future release			
Warm standby							

Model	499 NEH 10410	499 NEH 14100	499 NOH 10510
Description	Hub	Hub	Hub
Ethernet 10			
Ethernet 100			
Fiber ring			

TSX ETY 4102	TSX ETY 5102	TSX P57 2623M	TSX P57 2823M	TSX P57 3623M	TSX P57 4823M	TSX ETZ 410	TSX ETZ 510	Momentum M1E	Ethernet Comm adapter 170 ENT 1100	Ethernet Comm adapter 170 ENT 1101
Ethernet 10/100	Ethernet 10/100 FactoryCast	Ethernet 10/100	Ethernet 10/100	Ethernet 10/100	Ethernet 10/100	Ethernet 10/100	FactoryCast	Ethernet 10baseT	Ethernet 10baseT	Ethernet 10/100

	499 NES 17100	499 NOS 17100	499 NES 18100	499 NTR 10010	499 NTR 10100
	Switch	Switch	Switch	Transceiver	Transceiver

Transparent Factory

Quantum automation platform
Communication modules

Product type	TCP/IP Modbus Ethernet
---------------------	------------------------



Module function	<p>Embedded web diagnostics, Modbus/TCP, Network management, I/O scanner</p> <p>FactoryCast custom web pages, embedded web diagnostics, Modbus/TCP, Network management</p>
------------------------	--

Interfaces	1 10BASE-T/100BASE-TX port and 1 100BASE-FX port
-------------------	--

Connection type	Twisted pair cable and fiber optic cable
------------------------	--

Connector type	Shielded RJ45 for 100BASE-TX and MT/RJ for 100BASE-FX
-----------------------	---

Power consumption	1000 mA
--------------------------	---------

Controller compatibility	All Quantum CPU controllers, executive 2.0 or higher
---------------------------------	--

Software compatibility	Concept version 2.0 or higher ProWORX NxT version 2.0 of higher
-------------------------------	---

Model	140 NOE 771 00	140 NOE 771 10
--------------	----------------	----------------

TCP/IP Modbus Ethernet



Embedded web diagnostics, Modbus/TCP, Network management, I/O scanner, global data, FDR



FactoryCast custom web pages, embedded web diagnostics, Modbus/TCP, Network management, I/O scanner, global data, FDR

140 NOE 771 01

140 NOE 771 11

Transparent Factory

Premium automation platform
Communication modules

Product type TCP/IP Modbus Ethernet



Module function Modbus/TCP, Network management, Ethway
FactoryCast, Modbus/TCP, Network management, TCPOpen, Ethway

Interfaces 1 10BASE (AUI) and 1 10BASE-T (RJ45)

Connection type Triaxial cable and double twisted-pair

Connector type Shielded RJ45 for 10BASE-T and DB-15S for AUI

Power consumption 800 / 1200 mA

Controller compatibility All types of Premium processors

Software compatibility PL7 version 3.3 or higher

Model TSX ETY 110 TSX ETY 110 WS



Modbus/TCP, Network management, Ethway, Premium warm standby

Embedded web diagnostics, I/O scanner, Modbus/TCP, Network management, global data, FDR

Embedded web diagnostics, I/O scanner, Modbus/TCP, Network management, global data, FDR, FactoryCast custom web pages

1 10BASE-T/100BASE-TX port

Twisted pair cable

Shielded RJ45 for 10/100BASE-TX

370 mA

PL7 version 4.0 or higher

PL7 version 4.1 or higher

TSX ETY 210

TSX ETY 4102
(replaces TSX ETY 410)

TSX ETY 5102
(replaces TSX ETY 5101)

Transparent Factory

Premium automation platform
Communication modules

Product type	TCP/IP Modbus Ethernet
---------------------	------------------------



Module function	Embedded web diagnostics, I/O scanner, Modbus/TCP, Network management, global data, FDR
------------------------	---

Interfaces	1 10BASE-T/100BASE-TX port
-------------------	----------------------------

Connection type	Twisted pair cable
------------------------	--------------------

Connector type	Shielded RJ45 for 10/100BASE-TX
-----------------------	---------------------------------

Software compatibility	PL7 version 4.3 or higher
-------------------------------	---------------------------

Model	TSX P57 2623M	TSX P57 3623M
--------------	---------------	---------------

Premium CPU with embedded Ethernet



Embedded web diagnostics, I/O scanner, Modbus/TCP, Network management, global data, FDR, embedded Fipio

TSX P57 2823M

TSX P57 4823M

Transparent Factory

Momentum automation platform
Communication modules

Product type	TCP/IP Modbus Ethernet
---------------------	------------------------



Module function	984LL CPU
------------------------	-----------

Interfaces	1 10BASE-T port
-------------------	-----------------

Connection type	Ethernet twisted pair cable, I/O bus	Ethernet twisted pair cable, RS485 Modbus
------------------------	--------------------------------------	---

Connector type	Shielded RJ45 for 10BASE-TX, 9Pin for I/O bus	Shielded RJ45 for 10BASE-TX, 9Pin for Modbus RS485
-----------------------	---	--

Operating voltage	-
--------------------------	---

Power consumption	-
--------------------------	---

Software compatibility	Concept version 2.5 or higher ProWORX NxT version 2.0 or higher
-------------------------------	--

Model	171 CCC 960 20	171 CCC 980 20
--------------	----------------	----------------



IEC and 984LL CPU

I/O Communication adapter

Enhanced I/O communication adapter

1 10/100BASE-TX port

Ethernet twisted pair cable, I/O bus

Ethernet twisted pair cable, RS485 Modbus

Twisted pair cable

Shielded RJ45 for 10BASE-TX, 9Pin for I/O bus

Shielded RJ45 for 10BASE-TX, 9Pin for Modbus RS485

Shielded RJ45 for 10/100BASE-TX

Supplied from the Momentum I/O base.

Supplied from the Momentum I/O base.

Concept version 2.5 or higher
ProWORX NxT version 2.0 or higher

-

171 CCC 960 30

171 CCC 980 30

170 ENT 110 00

170 ENT 110 01

Product type	TCP/IP Modbus Ethernet
---------------------	------------------------



Module function	Ethernet TCP/ICP, embedded web diagnostics, Network management
------------------------	--

Interfaces	1 10/100BASE-TX (RJ45), 1 RS-485 (RJ45), 1 RS-232 (DB-9)
-------------------	--

Connection type	Twisted pair cable
------------------------	--------------------

Connector type	Shielded RJ45 for 10/100BASE-TX, DB-9S, mini-DIN
-----------------------	--

Terminal block	1 x 3 pin pluggable
-----------------------	---------------------

Operating voltage	19.2 to 32 VDC (24VDC nominal)
--------------------------	--------------------------------

Power consumption	200 mA maximum
--------------------------	----------------

Controller compatibility	TSX-37-10/21/22 controllers
---------------------------------	-----------------------------

Software compatibility	PL7 version 4.2 or higher
-------------------------------	---------------------------

Model	TSX ETZ 410
--------------	-------------



Ethernet TCP/ICP, embedded web diagnostics, Network management, FactoryCast custom web pages

TSX ETZ 510

Product type	Hubs
---------------------	------



Module function	Network hub		
------------------------	-------------	--	--

Interfaces	4-10BASE-T ports	3 10BASE-T ports 2 10BASE-FL ports	4-100BASE-TX ports
-------------------	------------------	---------------------------------------	--------------------

Connection type	Twisted pair cable	Twisted pair cable and redundant fiber optic ring	Twisted pair cable
------------------------	--------------------	--	--------------------

Connector type	Shielded RJ45 for 10BASE-T	Shielded RJ45 for 10BASE-T and BFOC for 10BASE-FL	Shielded RJ45 for 100BASE-TX
-----------------------	-------------------------------	---	---------------------------------

Terminal block	1 x 5 pin pluggable		
-----------------------	---------------------	--	--

Operating voltage	18 to 32 VDC safe extra-low voltage	9.6 to 57.6 VDC safe extra-low voltage	
--------------------------	-------------------------------------	---	--

Power consumption	80 mA typical, 130 mA maximum at 24 VDC	160 mA typical, 350 mA maximum at 24 VDC	200 mA typical, 270 mA maximum at 24 VDC
--------------------------	--	---	---

Model	499 NEH 104 10	499 NOH 105 10	499 NEH 141 00
--------------	----------------	----------------	----------------

Switches



Network switches

5 10BASE-T / 100BASE-TX and
2 100BASE-TX ports

5 10BASE-T / 100BASEW-TX and
2 100BASE-FX ports

8 10BASE-T / 100BASE-TX ports

Twisted pair cable and redundant fiber-optic ring

Twisted pair cables

Shielded RJ45

Shielded RJ45 for 10BASE-T / 100BASE-TX and
SC for 100BASE-FX

Shielded RJ45 for 10BASE-T / 100BASE-TX

18 to 32 VDC safe extra-low voltage

800 mA maximum at 24 VDC

125 mA typical, 290 mA maximum at 24VDC

499 NES 171 00

499 NOS 171 00

499 NES 181 00

Product type	Transceivers
---------------------	--------------



Module function	Network transceiver	
Interfaces	1 10BASE-T port and 1 10BASE-FL port	1 100BASE-TX port and 1 100BASE-FX port
Connection type	Twisted pair cable and fiber optic cable	
Connector type	Shielded RJ45 for 10BASE-T and ST (BFOC) for 10BASE-FL	Shielded RJ45 for 100BASE-TX and SC for 100BASE-FX
Terminal type	1 x 5 pin pluggable	
Operating voltage	18 to 32 VDC safe extra-low voltage	
Power consumption	80 mA typical, 100 mA maximum at 24 VDC	160 mA typical, 190 mA maximum at 24 VDC

Model	499 NTR 100 10	499 NTR 101 00
--------------	----------------	----------------

Bridges



Modbus to Ethernet bridge

Modbus Plus to Ethernet bridge

1 10BASE-T port with shielded RJ45 connector and 1 serial RS 232/RS 485 port with RJ45 connector

1 10BASE-T, 10BASE-2, AUI port; 1 single/dual cable Modbus Plus port

Twisted pair cable

Twisted pair cable and redundant fiber optic ring

Shielded RJ45

1 RJ45, AUI, BNC Ethernet cable; 1/2 DB-9S Modbus Plus cable(s)

3 screw terminals, fixed

-

24 VDC

110/220 VAC (-15%to 10%) 47 to 63 Hz

125 mA maximum at 24 VDC

1000 mA maximum

174 CEV 300 10

174 CEV 200 30

Product type Optical cables



Cable type Standard glass fiber optic

Preassembled connector type MT/RJ-SC duplex MT/RJ-ST duplex MT/RJ-MT/RJ duplex

Cable length 5 m (16.4 ft)

Radiation susceptibility No radiation along the cable

Agency approvals Category 5 of cabling standard EIA/TIA-568; Class D of IEC 11801 / EN50173

Model 490 NOC 000 05 490 NOT 000 05 490 NOR 000 05

Electrical cables



Shielded and foiled twisted pair straight through cable

Shielded and foiled twisted pair crossed over cable

RJ45 (two per cable)

2, 5, 12, 40, 80 m (6.5, 16.4, 39.4, 131.2, 262.4 ft)

5, 15, 40, 80 m (16.4, 49.2, 131.2, 262.4 ft)

UL, CSA 22.1 and NFPA 70 approval indicated by "U" after part number (example: 490 NTW 00040U); Category 5 of international cabling standard EIA/TIA-568; Class D of IEC 11801 / EN50173; Low Smoke Zero Halogen (LSZH); flame retardant of NFC32 070 #1 (C2) and CEI 322/1

490 NTW 000 ●●

490 NTC 000 ●●

Product type	Drives
---------------------	--------

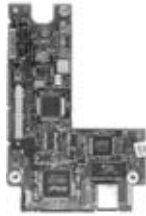

Module function	Ethernet communication
------------------------	------------------------

Interfaces	1 10BASE-T / 100BASE-TX port
-------------------	------------------------------

Connection type	Twisted pair cable
------------------------	--------------------

Connector type	Shielded RJ45
-----------------------	---------------

Terminal block	-
-----------------------	---

Operating voltage	-
--------------------------	---

Power consumption	-
--------------------------	---

Model	VW3A58310U
--------------	------------

Circuit monitor and gateways



Power meter

Modbus to Ethernet gateway

1 10BASE-T / 100BASE-TX port

1 10BASE-T / 100BASE-TX and 2 Modbus serial ports

1 10BASE-T / 100BASE-TX and 2 Modbus serial ports

1 x 3 pin pluggable

90-305 VAC, 100-300 VDC

21.6 to 26.4 VDC safe extra low voltage

50 mA maximum for VAC and 30 W maximum for VDC

300 mA maximum at 24 VDC

CM4000

EGX200

EGX400

Overview

TF Service selection guide

Transparent Factory services enables :

Communication between PLC stations, computers and other devices	■ Modbus TCP/IP
Configuration, diagnostics and HMI pages for Transparent Factory devices	■ HTTP web pages
Transfer of custom user web pages to a Transparent Factory device	■ FTP (file transfer protocol)
Management of the networking features of a Transparent Factory device using industry standard network management software	■ SNMP (simple network management)
Automatic network address allocation for devices on the network	■ BOOTP/DHCP
Automatic transfer of information between a PLC and other field devices such as Momentum input/output blocks, variable speed drives and any other Modbus compliant devices.	■ Input/output scanning
Real time data transfer between devices for data transfer and plant synchronization.	■ Global data
User customizable web pages to show live data from a Transparent Factory device.	■ FactoryCast
Automatic configuration and addressing of a replacement device to allow direct replacement of a failed device without user configuration.	■ Faulty device replacement (FDR)
Open TCP protocol implementation allowing users to implement a Transparent Factory device on any TCP protocol.	■ TCP open

Architecture (continued)

Presentation

Introduced by Schneider Electric, Transparent Factory provides seamless communication among automation, manufacturing and business systems. Networking technologies and new services make the sharing of information among sensors, controllers, workstations, third party and business systems more efficient than ever. Integrated web servers in automation controllers, networking components, and field devices provide transparent access to configuration information, remote diagnostic data, and integrated HMI features. The Transparent Factory cornerstone is industry standards and the heart of this foundation is the network Ethernet TCP/IP. Ethernet TCP/IP provides a single, uniform network capable of satisfying all the communication needs from automation sensors to factory management systems.

When many diverse systems are involved, Transparent Factory's use of standard technologies provides for important cost reductions in design, installation, maintenance and training.

Just as Ethernet TCP/IP has been built to fulfill all the needs of industrial systems, the physical Ethernet network has also been expanded to include products suited for harsh industrial environments.

The Transparent Factory offer consists of the following :

- **TF Ethernet services** - These services are built on Ethernet TCP/IP to meet the demands of the automation user in terms of functionality, performance and quality of service.
- **TF products for automation** - Schneider offers a full range of PLCs, distributed input/output, motor speed controllers, IPCs, gateways, and other devices that implement Transparent Factory services.
- **ConneXium, a complete Ethernet networking system** - ConneXium offers a robust range of hubs, switches, transceivers, and Ethernet cables well adapted to harsh factory environments.

Architecture (continued)

Nota : The numbers at the beginning of the following paragraphs refer to the corresponding numbers in the diagram at left.

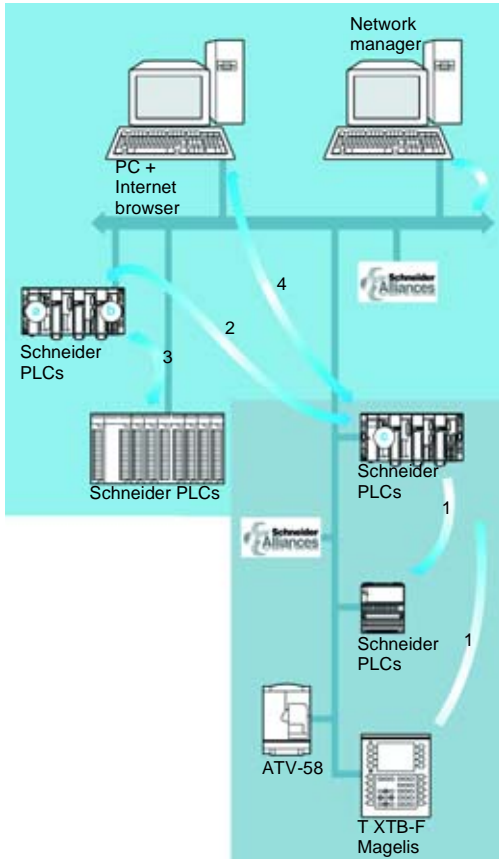

1. Vertical communication to the devices : PLC, PC fg peripheral devices

Application program is concerned with the control of input/output devices. Data must be transferred to and from a large number of different input/output devices in a fast, deterministic, repeatable manner. Response times are required to be in the range of 0.01 – 0.1 seconds.

Services available :

- input/output scanner
- Open Modbus TCP/IP messaging

1. Simple SCADA services : PC fg PLC, peripheral devices

A simple SCADA package is required to monitor or control a device or field equipment.

Services available :

- HTTP server – Custom web pages.

1. Automatic replacement of faulty devices : PLC fg peripheral devices

Assigning of Ethernet address and configuration parameters to a replacement device.

The system is required to automatically recognize and configure a replacement device that is installed without the need for user intervention or configuration.

Services available :

- FDR – Faulty device replacement

2. Horizontal communication : PLC fg PLC application synchronization, data transfer

Communication is required to transfer data between PLC applications and to synchronise several PLC applications. Data must be exchanged between several PLC stations in a time critical manner. Response times are required to be in the range of 0.01 – 0.5 seconds.

Services available :

- Global data

3. Horizontal communication : PLC fg PLC programming, diagnostic, data transfer

Simple communication interfaces are required to allow for the transfer of data between PLC applications. Data must be sent from one PLC station to another when required, but the frequency of the data transfer may vary. Response times are required to be in the range of 0.2 – 1 second.

Services available :

- Modbus TCPIP messaging

4. Vertical configuration of devices : PLC, PC fg peripheral devices

A device needs to have an IP address and associated parameters assigned automatically.

Services available :

- BOOTP
- DHCP

Architecture (continued)

4. PC to PLC communication : PLC fg computers MES, ERP

Communications of this type utilize standard networking infrastructure and protocols to exchange large data amounts with supervision or management systems. The PLC system may be required to implement a protocol that is custom to the connected system. Response time is not critical.

Services available :

- HTTP – Web pages and Java Applets
- OPC
- Open Modbus TCP/IP messaging
- TCP Open

4. PC to PLC communication : PLC fg computers SCADA

Communications of this type utilize standard networking infrastructure and protocols to exchange large data amounts with multiple PLC systems. Response times are required to be in the range of 0.5 – 2 seconds.

4. Configuration, monitoring and troubleshooting of devices : PC fg PLC, peripheral devices

A simple method is needed to configure, monitor or diagnose a device or PLC via a standard PC.

Standard services

Transparent Factory includes a comprehensive set of enhanced Ethernet services to customize Ethernet TCP/IP to the automation environment.

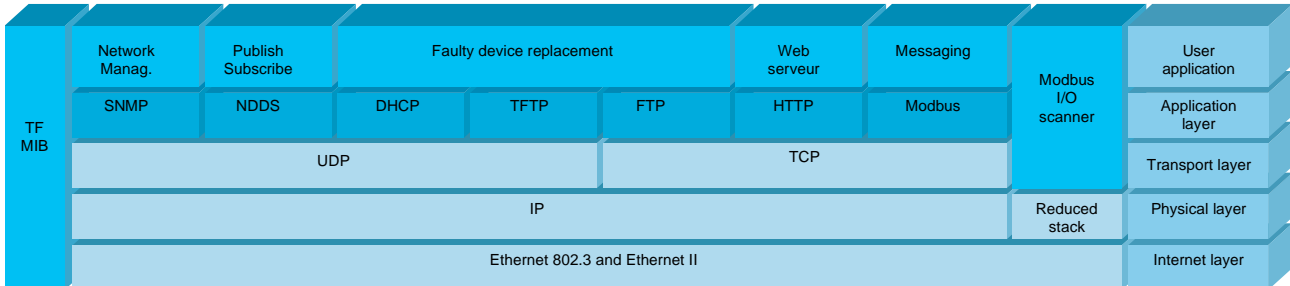

Modbus

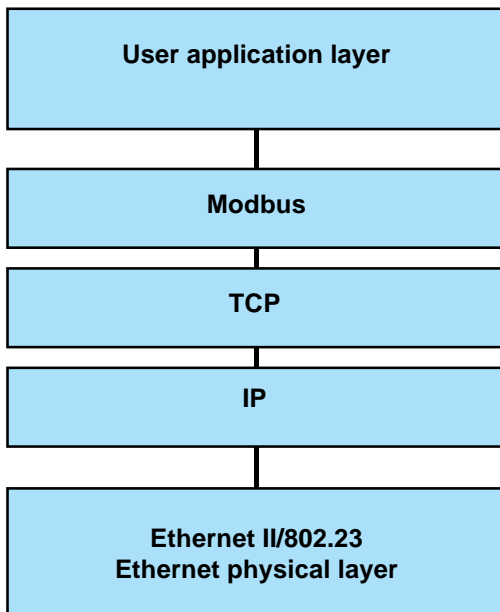

The open standard in the automation industry since 1979, Modbus has been combined with the backbone of the Internet revolution, Ethernet TCP/IP. Together these produce Modbus TCP/IP, a completely open, flexible Ethernet networking protocol. There are no proprietary chipsets or licensing fees required to develop a Modbus TCP/IP device. Modbus TCP/IP can be implemented on any device that supports a standard Ethernet TCP/IP stack. The Modbus TCP/IP protocol document can be downloaded from www.MOVBUS.org.

Modbus TCP is simple and open

The Modbus application layer is very basic, and well known. There are thousands of manufacturers currently implementing the Modbus standard, hundreds of these partners have already implemented Modbus TCP/IP as well as hundreds of new products that have chosen Modbus TCP/IP as the Ethernet standard. The simplicity of Modbus TCP/IP allows any simple field device like an input/output module to communicate on Ethernet, without a large amount of memory or high processing capacity. There are no proprietary chipsets or licensing fees required to develop a Modbus TCP/IP device.

The Modbus application protocol specification (that is used for both Ethernet and serial communications) is controlled by MODBUS.org, a group dedicated to developing the Modbus specification.

Modbus TCP is performance oriented

Due to the simplicity of the Modbus application layer, and the capacity of Ethernet 100 Mb, the performance of Modbus TCP is excellent. This allows the use of Modbus TCP/IP in time critical point to point applications like input/output scanning.

The Modbus application protocol is standard

The application protocol layer of Modbus is the same on Modbus serial line, Modbus Plus or Modbus TCP. This allows message routing from one network to another without the need for protocol conversion. Now that Modbus is implemented over TCP/IP, the additional benefits of IP routing become available to users. Modbus can now be routed between devices anywhere in the world, without regard for the distance or the different physical networks.

Schneider offers a full range of gateways to connect Modbus TCP/IP networks to existing Modbus Plus or Modbus serial networks.

Standard services (continued)

Modbus client/server messaging

All NOE 771 xx Quantum Ethernet TCP/IP modules provide the user with the ability to access data from the controller using the standard Modbus/TCP protocol. Any device – a PC, HMI package, another PLC, or any Modbus/TCP compliant device can access data from the PLC. The Modbus/TCP server also allows programming panels to log into the controller over Ethernet.

The Quantum and Premium Ethernet modules support up to 64 simultaneous Modbus/TCP client and server connections. They allow only one programming panel to be logged in at a time to guarantee consistency of changes to the controller configuration.

Momentum supports up to 14 simultaneous Modbus/TCP client and server connections and allows only one programming panel to be logged in at a time to guarantee consistency of changes to the controller configuration.

Assigned well known port

IANA (Internet Assigned Numbers Authority) has assigned well known port number TCP 502 to the Modbus protocol. Port 502 on the Ethernet TCP/IP stack is now dedicated to the Modbus protocol. This ensures compatibility to a wide variety of devices and the Modbus protocol. Today the Modbus protocol is the single most supported protocol among automation devices.

HTTP embedded web server (RFC 1945)

HTTP (Hypertext Transfer Protocol) is a protocol used to transmit web pages between a web server and a browser. HTTP has been used on the web since 1990.

The embedded web is one of the core elements of Transparent Factory and allows direct viewing of device information from anywhere in the world and from any level in an organization, all using a standard Internet browser such as Microsoft Explorer or Netscape Navigator.

Tasks that can be completed with a web browser include:

- View the devices configuration.
- Read data from the device.
- Modify the device configuration.
- Access embedded HMI pages for monitoring and control.
- View historical error logs.
- Configure additional user defined web pages.

BOOTP/DHCP (RFC 1531)

BOOTP/DHCP is used to dynamically provide IP addresses to devices. This removes the need to individually manage the IP address of each device and moves this management into a central IP address server.

The dynamic host configuration protocol (DHCP) provides internet hosts with configuration parameters. DHCP is an extension of BOOTP. DHCP consists of two components: a protocol for delivering host specific configuration parameters from a DHCP server to a host and a mechanism for allocation of network addresses to hosts.

Schneider devices can be:

- BOOTP clients, enabling the automatic assignment of an IP address to each device.
- a BOOTP server, enabling a Schneider Electric device to manage and assign IP addresses to other devices in the system.
- Schneider Electric builds on the BOOTP/DHCP protocol to implement faulty device replacement.

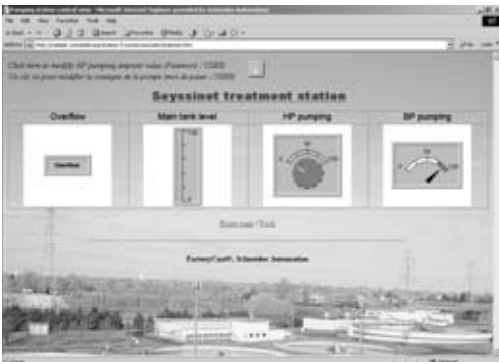

Standard services (continued)

FTP - File Transfer Protocol (RFC 959, 2228, 2640)

The File Transfer Protocol (FTP) provides the basic elements of file sharing. FTP is used by many systems to transfer files between devices.

Transparent Factory devices implement FTP as a standard method of transferring information to and from the device. This includes downloading new firmware and custom web pages.

SNMP - Simple Network Management Protocol (RFC 1155, 1156 and 1157)

The internet community developed the SNMP (Simple Network Management Protocol) standard to allow management of many diverse network devices using a single system. Network management systems can exchange information with SNMP compliant devices. This information allows the management system to monitor the state of the network and attached devices, to modify the configuration of devices, and to alarm failures of network devices.

Transparent Factory devices are SNMP compliant to allow them to fully integrate into a managed network.

Embedded web diagnostics

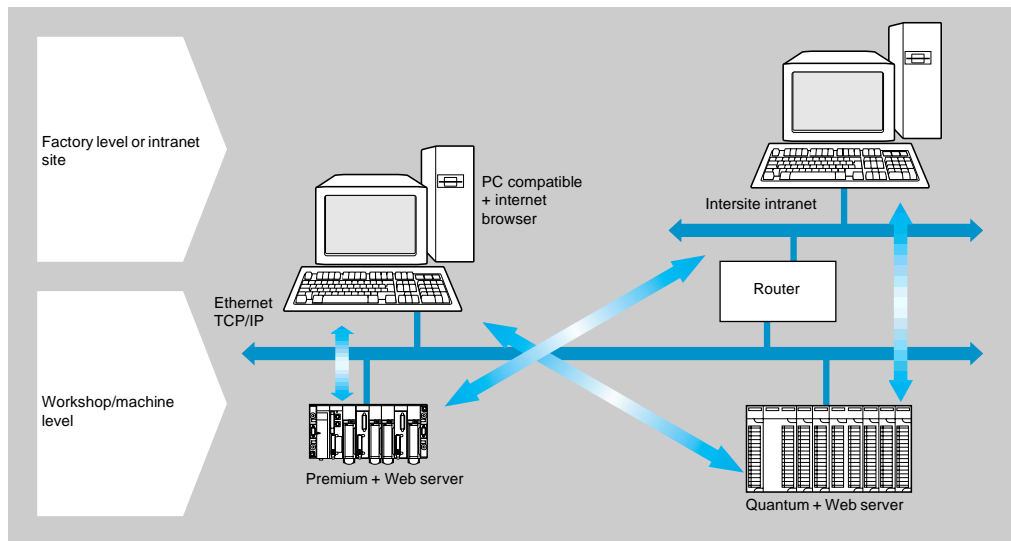

Schneider Automation controllers supporting Ethernet communication include an integrated, real time data web server. The embedded web diagnostics permit online access to Ethernet interface and controller configuration and diagnostics. None of the functions provided by the web server require any configuration or programming of either the Schneider controller or the PC supporting the internet browser. Moreover, this capability can be used in an existing application without any modification of the resident program.

The following device monitoring / diagnostic capability is provided by the integrated web server:

- Configuration menus for the DHCP server and SNMP.
- The Ethernet statistics for the interface.
- The configuration of the controller.
- The register values in the controller.
- The configuration, status and value of the remote input/output registers.
- The configuration, status and value of the distributed input/output registers.
- Interface crash log statistics.

Data from the integrated web server is presented as a standard HTML based web page. These web pages can be viewed across the internet using Microsoft Explorer or Netscape Navigator version 4.0 or greater and Sun JDK 1.1.4 or greater.

Standard services (continued)

Configured local rack - Premium rack viewer - Momentum input/output status

The local rack screen displays the current configuration of the local rack, including the controller, embedded server module and any input/output modules. The rack display can contain up to 16 slots.

Each module is displayed in its configured slot in the rack and the following information is provided:

- A label at the top of the Quantum module tells what type it is. Question marks indicate that the module type is unknown or the slot is empty. A vertical label displays the Premium module type and part number.
- An LED below the Quantum module label reports the module status:
 - Green indicates that the module is functioning properly,
 - Red indicates that the module is not functioning properly.
- The box in the upper left hand corner of the Premium module displays the slot number and module health:
 - A yellow box indicated the module is functioning properly,
 - A red box indicated the module is not functioning properly.

Click on a module icon to obtain detailed information about that module.

The Quantum CPU module icon contains two links. The top link leads to the controller status. The lower link leads to the distributed input/output display. The Premium CPU module icon (slot 1) contains two links. The top link leads to the FIP input/output module diagnostics page. The lower link leads to the PLC personality page.

A line leading down from the rack#0 icon (to the left of the rack) is a link to the next rack. When you place your mouse over this link, it turns into a red arrow. Each rack in the configuration may be viewed in turn. Upward links will take you back toward rack#0.

Controller status (Quantum - Premium - Momentum)

The CPU configuration page provides up to date information about the controller and its configuration. Access this page by selecting the CPU module or the hyperlink at the bottom of the page.

The Status message displays the operational status of the Quantum controller in a clear easy-to-read message display.

The LED indicators in the upper left-hand corner of the Premium screen provide a dynamic report on the controller status:

LED	Color if on	Meaning if on	Meaning if blinking	Meaning if off
Run	Green	Application running	Stopped	PLC error
ERR	Red	PLC error	Not configured	No error
Input/output	Red	Input/output event	–	No error
COM	Yellow	Communication error	–	No error

Some of the data provided on this page is dynamic. Dynamic data is constantly refreshed at a rate determined by the performance of the embedded server, network, and client CPU.



Standard services (continued)

Distributed input/output

Several web pages provide information about configured distributed input/output, including:

■ **Distributed input/output drops page**

Distributed input/output pages can be accessed by selecting either the CPU or a NOM from the configured local rack page assuming that distributed input/output is configured in the controller.

When you select a module on the configured local rack page configured for distributed input/output, you reach a page with detailed information about the distributed input/output networked drops controlled by that module.

The top half of the screen provides the current status (dynamic) and other data about the controller or NOM module running the distributed input/output network.

The bottom half of the screen displays an icon for each distributed input/output drop.

■ **Distributed input/output specific drop page**

When you click on a drop icon on the distributed input/output Network page, you reach a distributed input/output drop page with information about that drop.

The top part of the page reports the current status of the drop and the number of modules in the drop.

The bottom part of the page provides an icon for each module in the drop. A label at the top of the module identifies the module type.

- Green indicates that the module is functioning properly,
- Red indicates that the module is not functioning properly.

■ **Distributed input/output module pages**

When you click on a module icon on a distributed input/output drop page, you reach a distributed input/output module page with information about that module.

The top part of the screen provides information about the current status of the input/output module, its location, module type and input or output offset.

The LED panel in the lower part of the screen displays the status of the discrete input/output points:

- Green indicates the point is active,
- Off indicates the point is not active,
- It displays analog register values in integer format.

Ethernet statistics (Quantum - Premium - Momentum)

The Ethernet module statistics page provides information about the status, transmit and receive statistics and errors for the embedded server module. Access this page by selecting the NOE module from the local rack or use the hyperlink at the bottom of the page.

These statistics are for information only. To retain the information, it must be copied offline. The counters on the Quantum and Momentum Ethernet interface may be reset to zero by clicking the reset counter button.

The status message displays the operational status of the Quantum Ethernet interface in a clear easy-to-read message display.

The LED indicators in the upper left-hand corner of the Premium Ethernet statistics screen provide a dynamic report on the embedded server module status:

LED	Color if on	Meaning if on	Meaning if blinking	Meaning if off
Run	Green	Running normally	–	Power off
ERR	Red	Module default	Not configured	Running normally
ADR	Red	Network address fault or station out of range	–	No error

Some of the data provided on this page is dynamic. Dynamic data is constantly refreshed at a rate determined by the performance of the embedded server, network, and client CPU.

Standard services (continued)

Remote input/output

Several default web pages provide information about configured remote input/output, including:

- Remote input/output status page.

The remote input/output status page gives an overview of the status and health of the remote input/output network communications. Access this page by selecting the CRP drop down menu item, "remote input/output status".

Some of the data provided on this page is dynamic. Dynamic data is constantly refreshed at a rate determined by the performance of the embedded server, network, and client CPU.

- Configured remote input/output page.

The configured remote input/output page displays information about the remote input/output head processor and the number of remote input/output drops. This page can be accessed by selecting the CRP (RIO Head) module in the configured local rack page described previously.

The top half of the screen provides the current status (dynamic) and other data about the remote input/output head processor.

The bottom half of the screen displays an icon for each remote input/output drop and the drop number. Moving the cursor across the icons will display a text message in the browser status window indicating whether the drop is 800 series or Quantum input/output.

- Remote input/output drop page.

When you click on the icon for a remote input/output drop adapter on the configured remote input/output page, you reach a remote input/output drop page with detailed information about that drop.

The top part of the page reports the current status of the drop adapter and the number of modules in the drop.

The bottom part of the page provides an icon for each module in the drop. A label at the top of the module identifies the module type. Question marks indicate that the module type is unknown or the slot is empty. A colored LED reports module status:

- Green indicates that the module is functioning properly,
- Red indicates that the module is not functioning properly.

- Remote input/output drop module page.

When you click on a specific module on a remote input/output drop page, you reach a remote input/output module page with information about that module.

The top part of the screen provides information about the current status of the input/output module, its location, module type and input or output offset.

The LED panel in the lower part of the screen displays the status of the discrete input/output points:

- Green indicates the point is active,
- Off indicates the point is not active,
- It displays analog register values in integer format.

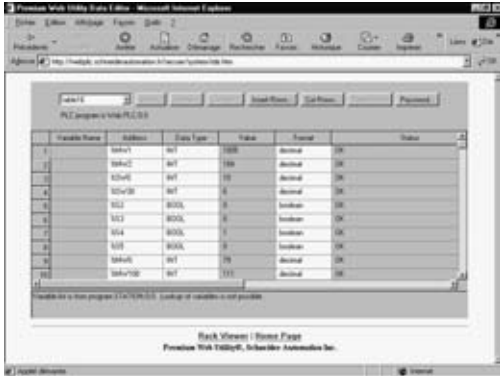

Standard services (continued)

Data monitor

The access to PLC variables is a predefined, password-protected function, which enables real-time read/write access to all PLC data.

These variables can be effectively entered and displayed in symbolic or physical reference formats. It is also possible to access unlocated variables. To modify these variables, they have to be declared «authorized» by the configuration software included with the web server module (Web Utility). To modify the values of these authorized variables, you have to enter an additional password.

Dynamic animation tables, containing the variables of the application to be monitored or modified, can be created by the user and saved in the module.

Configure NOE (Quantum)

The configure NOE web page provides configuration support information for SNMP, DHCP, and global data.

- The configure SNMP page allows the configuration of the SNMP agent database.
- The configure DHCP page allows the configuration of the IP address server database.
- The configure global data page allows the configuration of the publish/subscribe database.



Support (Quantum - Momentum)

The Support page provides information on contacting Schneider Automation and obtaining assistance regarding the 140 NOE 771 ●● Ethernet interface module.

Alarm Display

The Alarm Display is a predefined secure function (password-protected). Available with Premium controllers, it can be used to process alarms (display, acknowledgment and clear) managed at PLC level using monitoring function blocks known as Diagnostic Derived Function Blocks (DFB). These alarms are processed in exactly the same way as those for the “viewer” screens included in PL7 Pro and Monitor Pro software, CCX 17 operator panels or Magelis XBT F/T XBT F terminals.

Standard services (continued)

FactoryCast graphic object editor



The graphic object editor function can be used to create graphic views, which include animated graphic objects relating to PLC variables. These customizable views can be used in user Web pages (see "displaying predefined web pages" below). These views are created by simple copy/paste operations, and the object parameters are defined according to the user's requirements of color, PLC variables, name, etc. Views created in this way can be saved transparently to TSX ETY 110 WS/5101, 140 NOE 771 01, 140 NOE 771 11 Ethernet modules.

FactoryCast custom web pages

Both the Premium TSX ETY 110WS/5102 and Quantum 140 NOE 771 10/11 Ethernet embedded web server modules include a RAM based flash file system. This flash based file system provides storage for user defined web pages accessible via FTP.

User defined web pages can be created with any standard tool designed to create HTML pages (FrontPage, Word 97, PowerPoint, etc.). Web pages created in this manner allow the user to:

- Display all PLC variables in real time.
- Create hyperlinks with external servers (documentation creators, suppliers, etc.).

This feature is particularly suited to the creation of graphics and pictures for the eventual purposes of:

- Control, display, and diagnostics.
- Development of production reports in real time.
- Maintenance or operator guides.

FactoryCast configuration tool (Quantum - Premium)

The FactoryCast software supplied on a CD-ROM, with the Premium TSX ETY 110 WS/5102 and Quantum 140 NOE 771 10/11 modules, is the tool used to configure and administer the embedded web server. It is common to the Premium and Quantum automation platforms and is compatible with Windows 95/98 and Windows NT.

FactoryCast provides the following functions:

- Definition of user names and associated passwords.
- Definition of the variables to be modified by the user.
- Save/restore of the whole web site.
- Transfer web pages created locally by the user on a PC compatible system to or from the Premium TSX ETY 110 WS/5102 module and the Quantum 140 NOE 771 10/11 module.

Embedded web server configuration tools - Web page loader (Momentum)

The M1E web pages can be downloaded or updated via a web page loader.

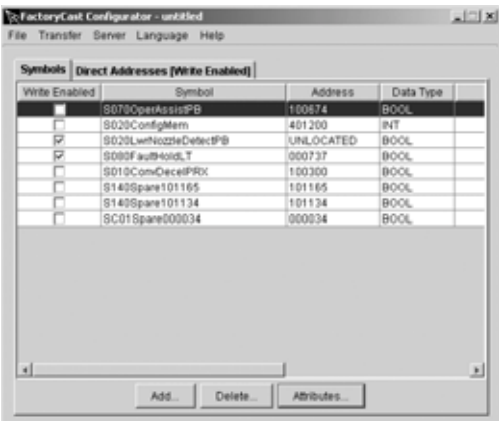

Overview input/output scanning

Input/output scanning

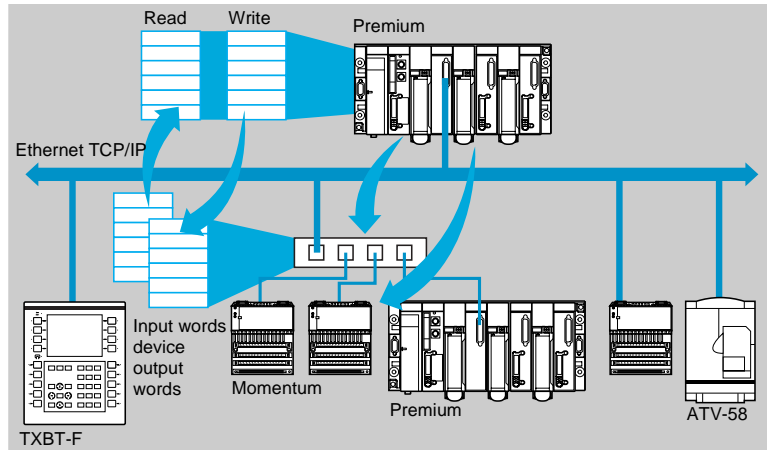

The input/output scanning service is used to exchange information between distributed input/output on the Ethernet Network. No special programming is required to utilize this service, only a simple configuration operation.

The distributed input/output modules are scanned transparently by means of Modbus/TCP read, write, or read / write requests. This principle of scanning via a standard protocol enables communication with any device, which supports a Modbus server on TCP/IP.

During operation, the input/output scanner service:

- Manages the TCP/IP connections with each of the distributed devices with the following input/output scanner limits: Quantum, 128 entries; Premium and Momentum, 64 entries.
- Scans the devices and copies the input/output to and from the configured local register/word zone.
- Provides service status words so that the PLC application can monitor the scanner operation.
- Applies pre-configured fallback values in the event of a communication problem.

Within the framework of the Schneider Alliances partnership program, Schneider Electric has developed an offer of hardware and software products which enable the input/output scanning protocol to be implemented on any type of product which can be connected to the Ethernet Network. Please consult your Regional Sales Office for details.

Input/output scanning diagnostics

Input/output scanning diagnostics are provided using 3 methods:

- To the PLC application program: diagnostics are provided using a data area inside the PLC.
- To the user via the programming packaged: diagnostics are provided using a graphical representation of the input/output scanning system in the programming package debug screen.
- To the user via a web page: diagnostics are provided to all users via a simple graphical web page that can be accessed with any standard web browser.



Faulty device replacement

Faulty device replacement combines BOOTP, DHCP, file storage and TFTP technologies to create a unique maintenance system for Ethernet devices.

Faulty device replacement creates a system where a replacement device is automatically detected, configured and brought into operation by the system, with no user intervention required.

The steps taken by FDR are outline below:

- A device that is configured as part of the FDR system fails.
- Another device is taken from the shelf, assigned the failed unit's role name and installed on the network.
- The FDR server (either a Quantum or Premium Ethernet module) will work together with the new device to configure its IP address and transfer necessary configuration settings, such as analog type and ranges, to the new device.
- The new unit will check that it is a compatible replacement with the configured device for this role and then commence operation.

Presentation

The Global data service is a real time publish/subscribe mechanism for distributing data among stations in a common distribution group. Global data permits the synchronization of PLCs, or the sharing of a common database between different applications.

The exchanges are based on a standard publish/subscribe protocol, which provides the best performance with a minimum network workload. This RTPS (Real Time Publish Subscribe) protocol is promoted by the IDA organization (Interface for Distributed Automation), and is already a standard, adopted by many other companies.

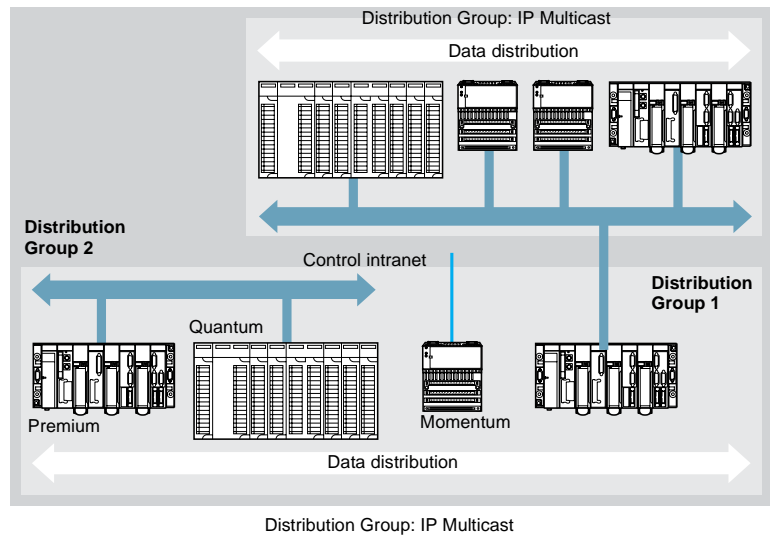

Characteristics

Up to 64 stations can participate in global data within the same distribution group.

Each station can:

- Publish 1 variable up to 1024 bytes. Publish period is configurable from 1 to n MAST scan.
- Subscribe to 1 to 64 variables. Refresh checking of each variable (health time-out from 50ms to 1s) is performed using health status bits. Total size of sub-scribed variables: up to 4 k contiguous bytes.
- The global data can be configured with the "multicast filtering option" which, when combined with ConneXium switches that support multicast filtering, will greatly enhance the Ethernet Network performance. Please refer to the ConneXium range selection guide for a list of compatible switches. If multicast filtering switches are not used, then multicast traffic will be treated as a broadcast.

Global data diagnostics

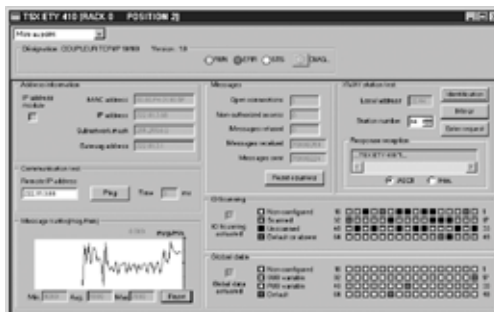

The diagnostics screens presents the status of the global data with different colors:

- Configured/not configured/In default.
- Publish/Subscribe.

Bandwidth monitoring

Bandwidth monitoring shows the loading of the Ethernet module. This allows users to monitor the load and anticipate problems before they occur. The load of an Ethernet module is shown in 3 ways:

- As an expected load in the programming software: (Premium).



- As a real-time graph via a web page.



- Via the SNMP interface to allow network management software to monitor the module load.

The bandwidth is displayed as a percentage of the module's available bandwidth that is dedicated to:

- Modbus messaging.
- Input/output scanning.
- Global data.
- Other.

SNMP - Simple network management protocol

Network management software allows a network manager to monitor and control network components and thus make it possible to isolate problems and find their causes. It allows a manager to:

- Interrogate devices such as host computers, routers, switches, and bridges to determine their status.
- Obtain statistics about the networks to which they attach.

Network management software follows the conventional client-server model. To avoid confusion with other network communication protocols that use the client/server terminology, network management software uses the terms:

- Manager for the client application that runs on the manager's computer.
- Agent for the application that runs on a network device.

Transparent Factory devices can be managed by any SNMP compliant network management system.

The simple network management protocol (SNMP) standard addresses the MIB objects basic issue regarding device management and configuration. The complexity of each device may require the device manufacturer to provide additional management objects not envisioned by the writers of the original SNMP specification.

The Schneider Electric Transparent Factory private MIB (Management Information Base) provides Schneider Automation specific management objects. These management objects facilitate the installation, configuration, and maintenance of Schneider Automation TF products in an open environment using standard, open platform SNMP management tools.

Transparent Factory devices implement 2 levels of SNMP network management.

Standard MIB II Interface – A basic level of network management is provided using a standard MIB II Ethernet interface MIB. This allows network management systems to identify the device on the network and gather general information about the configuration and operation of the Ethernet interface.

Transparent Factory Private MIB – Management of Transparent Factory devices is enhanced by the Transparent Factory private MIB. This MIB is a collection of information that allows network management systems to monitor the configuration and operation of all the Transparent Factory enhanced services.

The Schneider Electric Transparent Factory private MIB can be uploaded from the web server of any PLC Transparent Factory Ethernet communication module. Standard SNMP managers include HP openview and IBM netview.

	OS/Model	Ethernet TCP/IP profile
7	Application	Modbus
6	Presentation	Socket access
5	Session	
4	Transfer	TCP
3	Network	IP
2	Link	ISO 8802.2-ISO 8802.3
1	Physical	ISO 8802.3 (Ethernet) 10 Mbps

TCP Open access (for Premium)

The Premium Ethernet modules support a number of communication protocols based on the TCP/IP standard. Among these, the Modbus protocol has public specifications and its simplicity recommends it for the needs of communication with third-party devices. Consult the Schneider Alliance partners' program for details.

However, for certain applications, it may prove necessary to use other protocols. This is the case when, for example, users wish to integrate Premium platforms into existing architectures which use a particular communication protocol, possibly a proprietary one.

To meet these needs for open access, two interface levels are included in the Schneider Electric offer:

- A library of basic functions, which can be used in C language, enables direct access to the socket interface on TCP. Users can create their own communication functions using SDKC development software and take advantage of the ease of use this program offers in terms of development and debug.

Once generated, these function blocks are used in the application like any standard PL7 programming software function block.

- A library of basic function blocks known as EFs, which can be used directly in the application programs with PL7 language. These are the same as functions developed in C language described earlier, but are designed for use by non-computer specialists. These EF function blocks are not modifiable.

Functions

Operating in TCP connection client/server mode, the basic functions on the Berkeley socket interface enable:

- Management of 16 connections on the Open profile out of a maximum of 32.
- Creation of sockets and their attachment to any TCP port.
- Passage of these sockets to "listen for a connection request from a remote client" mode.
- Opening of a connection.
- Transmission and reception of data on these connections (240 bytes max.).
- Closing this connection.

Description

The TCP Open offer consists of a CD-ROM containing the TCP/IP function libraries. With open access on TCP, all the basic functions of TSX ETY 110 WS and TSX ETY 5102 modules can be used.

The TCP/IP TLX CD TCPA 33E function library comprises:

- The SDK C program enhancement library provides access to the module TCP/IP socket functions.
- The user manual in English (no printed version).
- EF elementary communication function blocks (Socket/Bind/Listen/Accept/Shutdown/Close/Send/Receive/Select/Set_Socket_Option/Connect) for installation using PL7 software (version 3 V3.3).
- Higher level EF function blocks, provided by way of example, which can perform more advanced functions such as the complete sequence for establishing or closing a connection, or sending or receiving data. The source files for all these EF blocks are also supplied.
- An example of a PL7 application communicating with a TELNET application on a PC.

If dedicated function blocks need to be created, the SDKC program for C language function development, version V3.3 should be installed on the development station.

TCP open access (for Premium) (continued)

Setup precautions

The development of C language functions requires compliance with certain setup precautions:

- To set up these services, the user should be familiar with the TCP/IP profile. In addition, since the SDK C program enables access to all the PLC internal resources, all the necessary precautions should be taken when developing EF communication blocks to avoid endangering the PL7 application, especially on the commonly fragile operating modes such as cold/warm restarts, response to a fault, etc.
- The user should also take care to maintain the requests from the different communication profiles at a level compatible with the performance required by the application.
- Finally, it is the responsibility of the client application software (PL7 or C program) to manage the operating modes for communication, which may be specific to the application. For example, what would be the result if a remote device failed to respond, or in the event of a break in a connection.

For these reasons, we recommend that you consult your Regional Sales Office to ensure that your TCP protocol open access project is feasible.

Protocol drivers

As Transparent Factory is based on open Ethernet standards there are no custom drivers that are required to operate a system.

A general summary of the drivers used and how they are supplied is shown below:

PC services - Drivers required

Modbus TCP/IP – Open Standard, supplied by each product vendor.
HTTP – Open Standard, included in common operating system such as MS Windows.
FTP – Open Standard, included in common operating system such as MS Windows.
DHCP/BOOTP – Open Standard, included in common operating system such as MS Windows.
SNMP – Open Standard, included in common operating system such as MS Windows.

PLC services - No drivers required for a PC

input/output Scanning – Implement on the Modbus TCP/IP Standard.
Global Data – Implemented using the NDDS Protocol, Driver included with each Ethernet module.
Faulty Device Replacement – Based on DHCP and FTP/TFTP.

Legacy drivers

Premium:
All the drivers for Premium are available on a single CD-ROM.
PL7 is delivered with Uni-Telway driver only.

Modbus Plus - Drivers are available on a single CD-ROM.
Modbus - No drivers required.

Network systems

Transparent Factory can be implemented using any standard Ethernet Network layout.

Transparent Factory networks can be constructed using any combination of network topologies or physical connections.

Schneider provides a complete range of industrially enhanced networking components.

An Ethernet Network can be constructed using any of the following layouts or a combination of several network layouts.

Line topology

The 499 N●S 171 00 ConneXium switch can be used to create a IEEE 802.3u twisted-pair or fiber-optic network. The connections are made via Port 6 and Port 7 of the ConneXium switch.

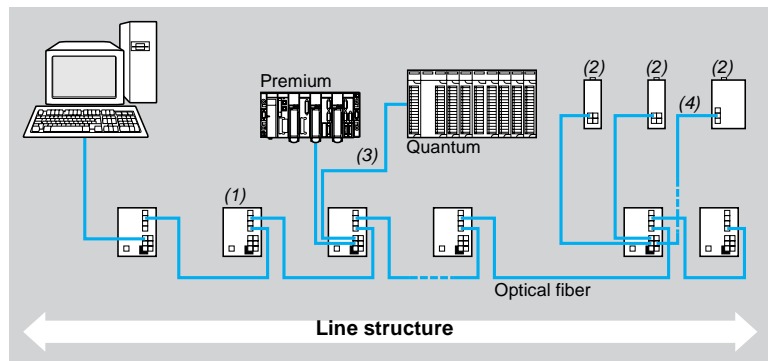

- (1) ConneXium 499 N●S 171 00
- (2) ConneXium 499 NEH 141 00
- (3) Shielded twisted pair crossed cord (499 NTW 000 ●●)
- (4) Shielded twisted pair cord (499 NTW 000 ●●)

Star topology

The 499 NEH 104 10 ConneXium hub allows the connection of up to four IEEE 802.3 data terminal devices or additional twisted-pair Ethernet segments via twisted-pair cable. The 499 NEH 141 00 ConneXium hub allows the connection of up to four IEEE 802.3u data terminal devices or one additional 499 NEH 141 00 ConneXium hub via twisted-pair cable.

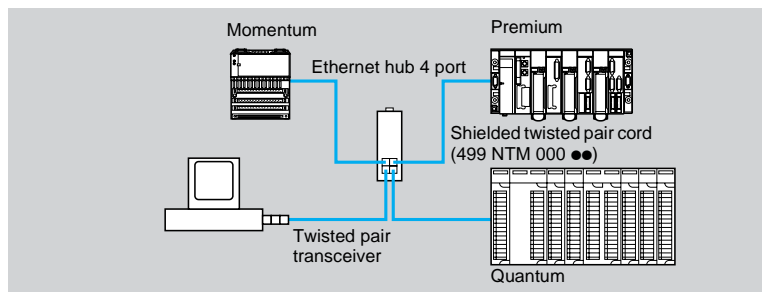

Ring topology

Transparent Factory network systems can be designed with higher availability using specific hubs or switches linked on a redundant copper or optical ring. If the ring is damaged, the communication will be maintained transparently in less than 500 ms.

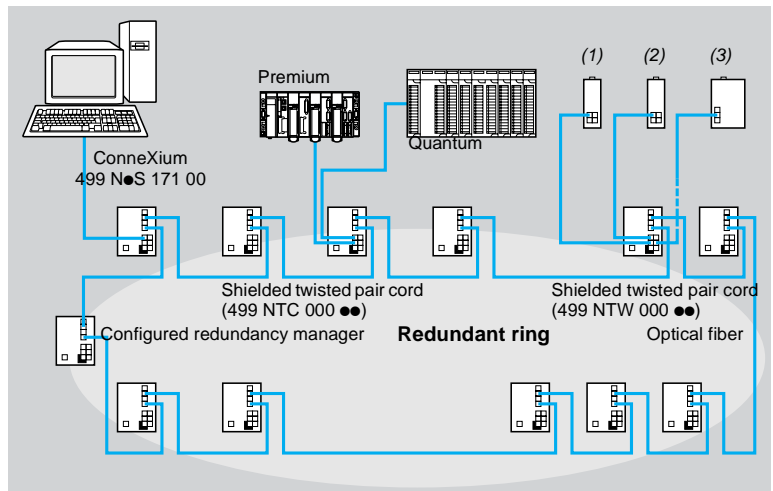
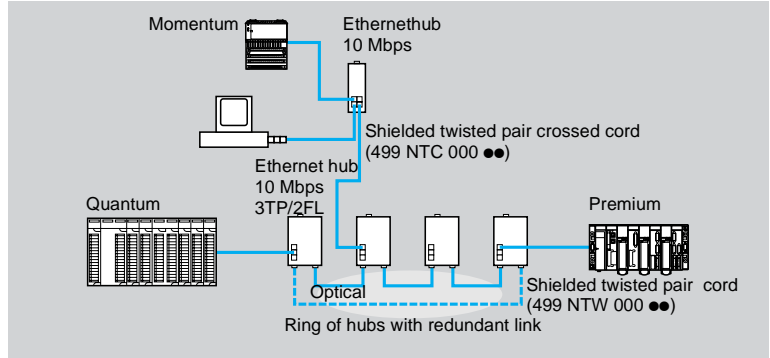

- (1) ConneXium 499 NEH 141 00
- (2) ConneXium 499 NEH 104 10
- (3) ConneXium 499 NOH 105 10

The NoS is integrated into the ring via the backbone ports (ports 6 and 7). If a line section fails, the ring structure of up to 50 NxS switches transforms back to a Bus type configuration within 0.5 seconds.

Nota : The function "Redundant ring" requires the following setting for ports 6 and 7: 100 Mbps, full duplex and auto negation (which is the factory default setting).

These products are available with the possibility to duplicate the power supply.

Together with Warm Standby or Hot Standby PLC offer, they will guarantee the maximum of availability to your automation installation.

Interconnected redundant rings topology

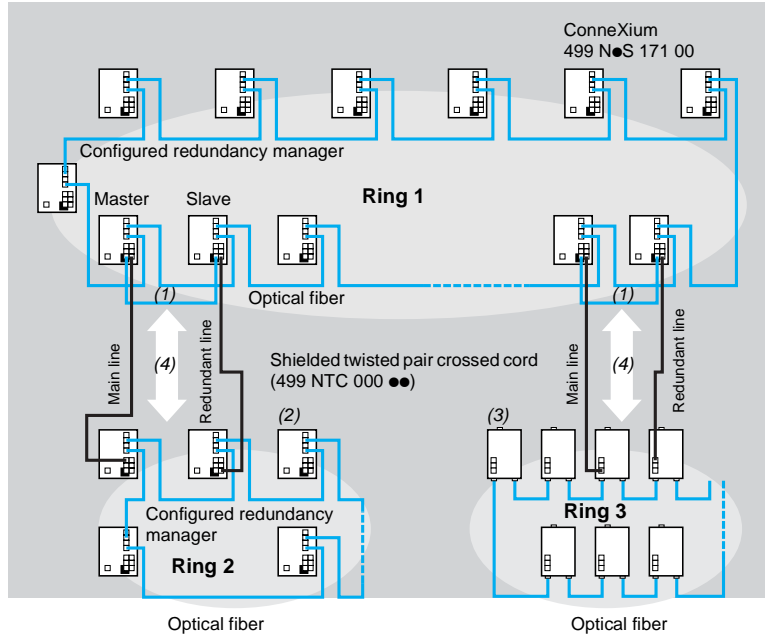

- (1) Control line
- (2) ConneXium 499 NoS 171 00
- (3) ConneXium 499 NOH 105 10
- (4) Redundant coupling of ring 1 and ring 2

Maximum switching time from normal to back up link line is 500 ms.

The collision domain

Layer 2 Ethernet protocol is based on a collision detection mechanism called CSMA/CD Carrier – Sense Multiple Access/Collision Detect. Each station sends a message when needed and listens to see if the message is interrupted by a message from another station. This interruption is called a collision. If a collision occurs, the station will retransmit the data after waiting an appropriate time. This results in an increased network load.

Due to the data transmission time from one end of the network to the other, there is a maximum network length beyond which undetected collisions may occur. For that reason, for each technology, a maximum network extension is defined. Considering the topology, we speak about "maximum network diameter" in the same collision domain. This maximum network diameter must be calculated for the worst-case distance, between the most distant stations in term of transmission time. This transmission time depends on:

- The physical distance between the stations.
- The number of intermediate stations (hubs, transceiver).

In order to extend a network beyond the limits of a collision domain, a switch or router is required.

Methods for reducing collisions include:

- Implement a full duplex network allowing simultaneous transmission and reception of data.
- Constructing a switched Ethernet Network with switches instead of hubs will remove collisions from the network.

Each Ethernet Network topology and physical layer are limited by several factors. Some limits are imposed by standard Ethernet design rules. Additional limits are imposed in the automation environment to ensure real time operation.

Network components

Hubs

Hubs are used to connect several 10BASE-T or 100BASE-TX devices together in a star configuration. Several hubs can be connected together to form a tree configuration, however all devices connected to a series of hubs belong to the same collision domain and hence the size of a hub-based network is limited.

Switches

Switches are used to connect several 10/100BASE-T devices together in a star configuration. Many switches can be connected together to form large tree structures. As a switch limits the collision domain they are used to increase network size and performance.

Transceivers

Connecting to existing networks – interference insensitive fiber optic cables can connect network end devices (controllers, drives, electric meters, etc.) in an industrial environment.

The 499 NTR 100 10 ConneXium Transceiver can be integrated into an existing 10 Mbit/s network with:

- 499 NEH 104 10 ConneXium 4 Port hub.
- 499 NOH 105 10 ConneXium 5 Port hub.
- 499 NXS 171 00 ConneXium 7 Port Switch.
- 499 NES 181 00 ConneXium 8 Port Switch.

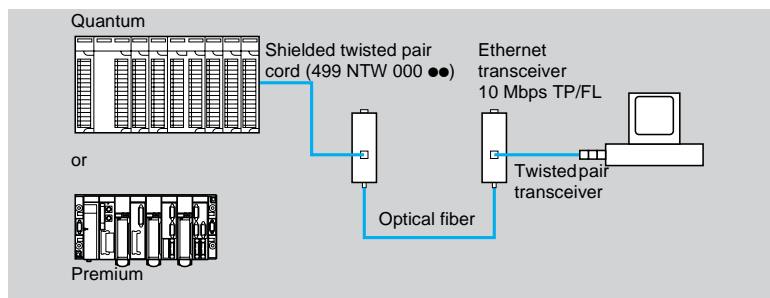

The 499 NTR 101 00 ConneXium Transceiver can be integrated into an existing 100 Mbit/s network with:

- 499 NEH 141 00 ConneXium 4 Port hub.
- 499 N●S 171 00 ConneXium 7 Port Switch.
- 499 NES 181 00 ConneXium 8 Port Switch.

The maximum number of cascaded ConneXium Transceivers between network end devices or repeaters is two.

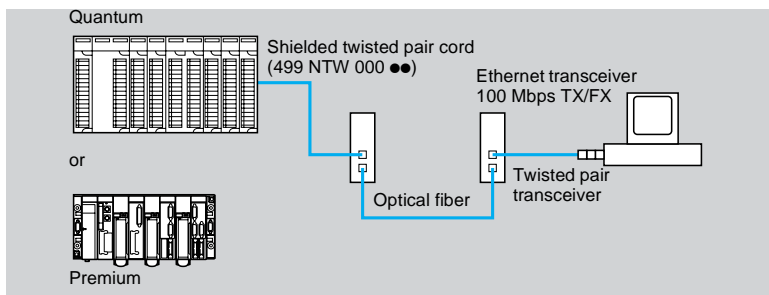

Routers

Routers are generally used at the enterprise backbone level, to link different departments or different sites. They are sometimes associated with functions like the firewall for filtering remote access. A router needs to be configured in order to route the messages to the appropriate destination. The routing mechanisms are based on the IP address. The stations are grouped on the same sub network according to their IP address. Any message to a remote network will be sent to the router which will route the message to the correct destination. All our Ethernet modules can be configured with a gateway default address and a subnet mask, to allow IP routing.

RAS servers

RAS Servers are designed to provide access to an Ethernet Network from a remote location. In general RAS servers are used to link either a remote device to an existing network or to join two Ethernet Networks via phone or ISDN lines.

General characteristics of physical Ethernet standards used in the automation industry

	Data Rate (Mbits/s)	Medium	Connector type	Duplex	Advantage
10BASE-T	10	Twisted pair (SFTP)	RJ45	–	Cost
10BASE-FL	10	Optical fiber (generally 62.5/125 multimode 1300 nano meter)	ST or BFOC	–	Immunity, security
100BASE-TX	100	Twisted pair (SFTP)	RJ45	Full	Data Rate (x50)
100BASE-FX	100	Optical fiber (Multi mode or Single mode)	SC or MT-RJ	Full	Noise immunity, security

Nota : For additional information regarding network design and installation, consult: Network Design Services Team in North Andover, Transparent Factory User Guide (available on Enterprise), Network Design and Installation Guide (available on Enterprise)

Redundancy

Transparent Factory network systems can be designed with higher availability using specific hubs or switches linked on a redundant copper or optical ring. If the ring is damaged, the communication will be maintained transparently in less than 500 ms.

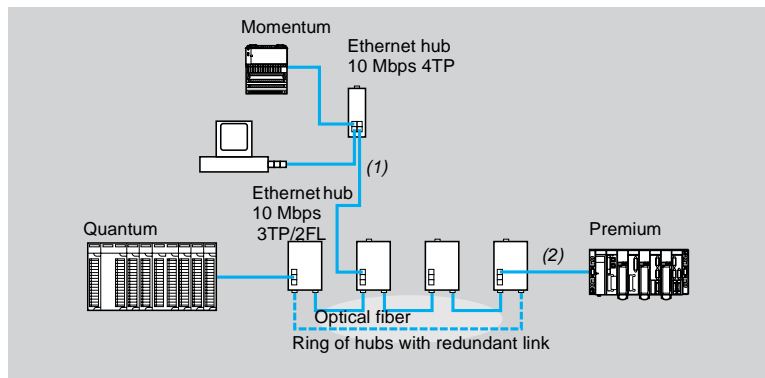

(1) Shielded twisted pair cord crossed (499 NTC 000 ●●)
 (2) Shielded twisted pair cord (499 NTW 000 ●●)

Redundancy (continued)

These products are available with the capability of duplicating the power supply.

Together with Warm Standby or Hot Standby PLC offer, they will guarantee the maximum availability to your automation installation.

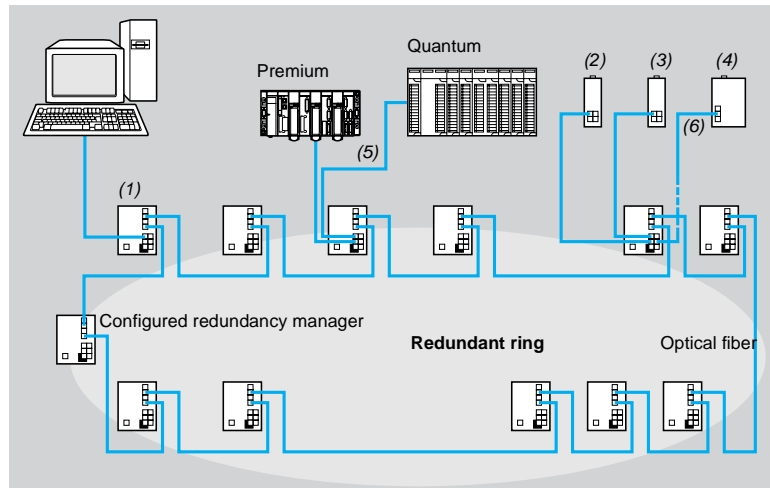

- (1) ConneXium 499 N●S 171 00
- (2) ConneXium 499 NEH 141 00
- (3) ConneXium 499 NEH 104 10
- (4) ConneXium 499 NOH 105 10
- (5) Shielded twisted pair cord (499 NTW 000 ●●)
- (6) Shielded twisted pair cord (499 NTC 000 ●●)

The N●S is integrated into the ring via the backbone ports (ports 6 and 7). If a line section fails, the ring structure of up to 50 N●S switches transforms back to a Bus type configuration within 0.5 seconds.

Nota : The function "Redundant Ring" requires the following setting for ports 6 and 7: 100 Mbps, full duplex and auto negation (which is the factory default setting)

Description

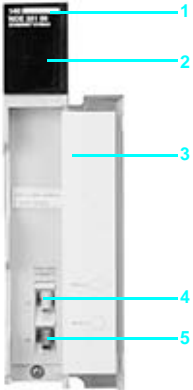

The module 140 NOE 771 00/10 comprises on the front panel:

- 1 Model number and color code.
- 2 LED array.
- 3 Removable, hinged door and customer identification.
- 4 Fiber optic transmit cable port.
- 5 Fiber optic receive cable port.

Mechanical construction

Model	140 NOE 771 00	140 NOE 771 10
Operating temperature	°C (F) 0 to 60 (32 to 140)	
Relative humidity	0 ... 95% (non condensing)	
Dimensions (W x H x D)	mm (in) 250 x 103.85 x 40.34 (9.84 x 4.09 x 1.59)	
Weight	g (lb) 345 (0.76)	
Enclosure	IP 20	
Agency approvals and compliance	UL 508, CSA 22.2-142, FM Class 1 Division 2, CE	

Characteristics

Module type	I/O scanner	Embedded web server
Technology	Ethernet 100 Mbit/s	
Interfaces	1 100BASE-TX port with shielded RJ45 connectors, 1 100BASE-FX with MT/RJ connector	
Connection types	Twisted pair cable and Fiber optic cable	
Power consumption	mA	750 typical, 1000 maximum
Maximum range	m (ft)	100BASE-TX – 100 (328) and 100BASE-FX – 100 (326)
LED indicators	Active, ready, fault, run, collision, link, transmit active, receive active, kernel, 10MB, 100MB, Fduplex, appl.	

Description

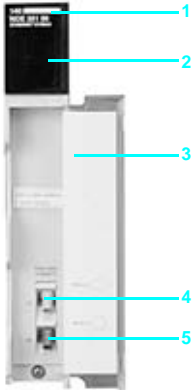

The module 140 NOE 771 01/11 comprises on the front panel:

- 1 Model number and color code.
- 2 LED array.
- 3 Removable, hinged door and customer identification.
- 4 Fiber optic transmit cable port.
- 5 Fiber optic receive cable port.

Mechanical construction

Model		140 NOE 771 01	140 NOE 771 11
Operating temperature	°C (F)	0 to 60 (32 to 140)	
Relative humidity		0 ... 95% (non condensing)	
Dimensions (W x H x D)	mm (in)	250 x 103.85 x 40.34 (9.84 x 4.09 x 1.59)	
Weight	g (lb)	345 (0.76)	
Enclosure		IP 20	
Agency approvals and compliance		UL 508, CSA 22.2-142, FM Class 1 Division 2, CE	

Characteristics

FactoryCast supported		No	Yes
Technology		Ethernet 100 Mbit/s	
Memory size	MB	8	
Interfaces		1 100BASE-TX port with shielded RJ45 connectors, 1 100BASE-FX with MT/RJ connector	
Connection types		Twisted pair cable and Fiber optic cable	
Power consumption	mA	750 typical, 1000 maximum	
Maximum range	m (ft)	100BASE-TX and 100BASE-FX - 100 (326)	
LED indicator		Active, ready, fault, run, collision, link, transmit active, receive active, kernel, 10MB, 100MB, Fduplex, appl.	

Description

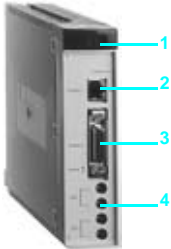

The TSX ETY 110/110 WS modules are single format modules, which are installed in a rack slot of a Premium PLC station.

The front panel on the TSX ETY 110/110 WS module comprises:

- 1 A display block indicating the state of the module.
- 2 A standard connector for 10BASE-T interface (RJ45).
- 3 A standard connector for 10BASE-5 interface (AUI).
- 4 Four thumbwheels for defining the station number and network number.

The maximum number of modules permitted (1 to 4) per configuration depends on the type of processor.

Mechanical construction

Model	TSX ETY 110	TSX ETY 110 WS
Operating temperature	°C (F) 0 to 60 °C (32 to 140)	
Relative humidity	30% to 95% (non condensing)	
Dimensions (W x H x D)	mm (in) Single format module	
Weight	g (lb) 370 (0.8)	
Enclosure	IP 20	
Agency approvals and compliance	UL 508, CSA 22.2-213, FM Class 1 Division 2, CE	

Characteristics

Technology	CSMA/CD	
FactoryCast supported	No	Yes
Interfaces	1 10BASE-T interface (RJ45) and 1 10BASE-5 interface (AUI)	
Connection types	Twisted pair cable and AUI cable	
Power consumption	mA	800 typical, 1200 maximum
Maximum range	m (ft)	RJ45 = 100 (328), AUI = 50 (164)
LED indicator	RUN, ERR (Error), STS (Status)	

Description



The TSX ETY 4102/5102 modules are single format modules, which are installed in a rack slot of a Premium PLC station.

The front panel on the TSX ETY 4102/5102 module comprises:

- 1 A display block indicating the state of the module.
- 2 A standard connector for 100BASE-TX interface (RJ45).

The maximum number of modules permitted (1 to 4) per configuration depends on the type of processor.

Mechanical construction

Model	TSX ETY 4102	TSX ETY 5102
Operating Temperature	°C (F) 0 to 60 (32 to 140)	
Relative Humidity	30% to 95% (non condensing)	
Dimensions (W x H x D)	mm (in) Single format module	
Weight	g (lb) 370 (0.8)	
Enclosure	IP 20	
Agency Approvals and Compliance	UL 508, CSA 22.2-213, FM Class 1 Division 2, CE	

Characteristics

Technology	CSMA/CD	
FactoryCast Supported	No	Yes
Interfaces	1 10/100BASE-TX interface (RJ45); I/O scanner	
Connection Types	Twisted pair cable	
Power Consumption	mA	360
Maximum Range	m (ft)	100 (328)
LED Indicator	RUN, ERR (Error), STS (Status)	

Description

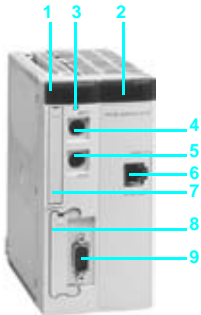

The TSX P57 2623M / 2823M / 3623M / 4823M modules are double format modules, which are installed in a rack slot of a Premium PLC station.

The front panel on the TSX P57 2623M / 2823M / 3623M / 4823M module comprises:

- 1 Display block with 5 indicator lamps:
 - RUN lamp (green): on if the processor is operating (program execution).
 - ERR lamp (red): signals faults relating to the processor and its on board devices (PCMCIA memory card and PCMCIA communication card).
 - I/O lamp (red): signals faults on another station module or a configuration fault.
 - TER lamp (yellow): signals activity on the terminal port.
 - FIP lamp (red): when flashing, it signals activity on the integrated Fipio bus.
- 2 Display block for integrated Ethernet port with 5 indicator lamps:
 - RUN lamp (green): Ethernet port ready.
 - ERR lamp (red): fault Ethernet port.
 - COL lamp (red): detection of collision.
 - STS lamp (yellow): Ethernet link diagnostic.
 - Two lamps TX and RX (yellow): transmission or reception of data.
- 3 RESET button causing a cold restart of the PLC when it is activated.
- 4 A 8 way female mini-DIN connector (TER): for connecting a programming or adjustment terminal.
- 5 A 8 way female mini-DIN connector (AUX): for connecting a peripheral device.
- 6 A RJ 45 connector for connection to Ethernet network.
- 7 Slot for a type 1 PCMCIA format memory extension card.
- 8 Slot for a type 3 PCMCIA format communication card.
- 9 A 9 way SUB-D connector (on TSX P57 2823/4823M only) for Fipio bus manager communication.

The maximum number of modules permitted (1 to 4) per configuration depends on the type of processor.

Mechanical construction

Model	TSX P57 2623M / 2823M / 3623M / 4823M	
Operating temperature	°C (F)	0 to 60 (32 to 140)
Relative humidity		30% to 95% (non condensing)
Dimension W x H x D	mm (in)	Double format module
Weight	g (lb)	560 (1.233)
Enclosure		IP 20
Agency approvals and compliance		CE, UL, CSA, IEC 61131-2

Characteristics

Technology		CSMA/CD
Interfaces		1 10/100BASE-TX interface (RJ 45)
RAM memory		2623 - 48K; 2823 and 3623 - 64K; 4823 - 96K
Maximum extended memory		2623 and 2823 - 160K; 3623 - 384K; 4823 - 512K
Fipio support		2823 and 4823 only
Number of third-party Fieldbuses supported		2623 and 2823 - one; 3623 and 4823 - two
Connection types		Twisted pair cable
Maximum range	m (ft)	100 (328)
LED indicator		RUN, ERR (Error), COL (Collision), STS (Status), TX (Transmission), and RX (Reception)

Description

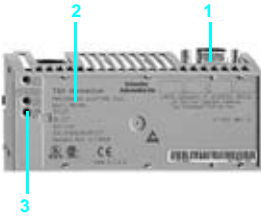

The 170 ENT 110 00/01 Ethernet communication adapter comprises on the front pane:

- 1 Ethernet network connector interface (RJ 45)
- 2 Area for label (label shipped with I/O base).
- 3 LED status indicators comprising:
 - RUN (green), module health.
 - LAN ACT (green), Ethernet network status.

Mechanical construction

Model		170 ENT 110 00	170 ENT 110 01
Operating temperature	°C (F)	0 to 60 (32 to 140)	
Relative humidity		5...95% (non condensing)	
Dimensions (W x H x D)	mm (in)	125 x 61.02 x 25.9 (4.86 x 2.37 x 1.01)	
Weight	g (lb)	42.5 (0.0938)	
Enclosure		IP 20 conforming to IEC529	
Agency approvals and compliance		UL, CE, CSA, FM Class 1, Division 2	UL, CE, CSA

Characteristics

Technology		Ethernet 10 Mbit/s	Ethernet 10/100 Mbit/s
Interfaces		1 10BASE-T port with shielded RJ45 connectors	
Connection types		Twisted pair cable	
Power consumption	mA	Power supplied by Momentum I/O base	
Maximum range	m (ft)	10BASE-T - 100 (328)	
LED indicator		RUN, LAN, ACT	

Description

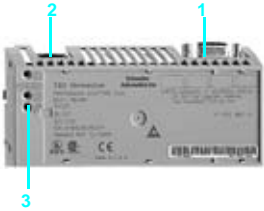

The 171 CCC 960 20/30 and 171 CCC 980 20/30 Momentum controller comprises on the front panel:

- 1 Ethernet network connector interface (RJ 45).
- 2 Optional second port (Modbus or I/O bus).
- 3 LED status indicators comprising:
 - RUN (green): controller health.
 - LAN STS (green): Ethernet network status.
 - LAN ACT (green): detected Ethernet traffic.

Mechanical construction

Model	171 CCC 960 20	171 CCC 980 20	171 CCC 960 30	171 CCC 980 30
Operating temperature	°C (F) 0 to 60 (32 to 140)			
Relative humidity	5 ... 95% (non condensing)			
Dimensions (W x H x D)	mm (in) 125 x 61.02 x 25.9 (4.86 x 2.37 x 1.01)			
Weight	g (lb) 42.5 (0.0938)			
Enclosure	IP 20 conforming to IEC529			
Agency approvals and compliance	UL, CE, CUL, FM Class 1 Division 2, NEMA 250 Type , and IP20 conforming to IEC52			

Characteristics

Technology	Ethernet 10 Mbit/s			
Interfaces	1 10BASE-T Ethernet port with shielded RJ 45 connector	1 10BASE-T Ethernet port with shielded RJ45 connector, 1 RS 485 port	1 10BASE-T Ethernet port with shielded RJ 45 connector	1 10BASE-T Ethernet port with shielded RJ45 connector, 1 RS 485 port
Memory	512K	512K	1Mb	1 Mb
Connection types	Twisted pair cable			
Power consumption	mA	Power supplied by Momentum I/O base		
Maximum range	m (ft)	10BASE-T – 100 (328)		
LED indicator	RUN, LAN ACT, LAN STS			

Description

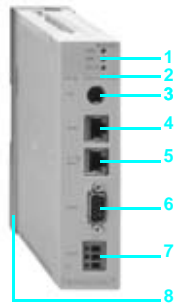

The Ethernet TSX ETZ 410/510 modules are autonomous and thus do not fit into a Micro PLC rack, but fit onto a DIN profile or on an AM1 PA perforated mounting plate.

The front of the TSX ETZ 410/510 modules are arranged as follows:

- 1 Three display LEDs indicating the module's status (RUN, ERR, RX/TX).
- 2 A screened on label indicating the module's MAC address (default address set in the factory).
- 3 A mini-DIN connector for terminal port (TER address).
- 4 An RJ 45 connector for Uni-Telway auxiliary port RS 485 serial link (RS 485 address).
- 5 An RJ 45 normalized connector for connecting to the Ethernet network (10/100BASE-TX address).
- 6 A 9 pin male SUB-D connector for RS 232 serial link (modem).
- 7 A screw terminal block for connecting to the external 24 VDC power supply.
- 8 A support plate enabling it to be fixed to the module.

Mechanical construction

Model		TSX ETZ 410	TSX ETZ 510
Operating temperature	°C (F)	0 to 60 (32 to 140)	
Relative humidity		30% to 95% (non condensing)	
Dimensions (W x H x D)	mm (in)	34.63 x 150 x 116.7 (1.36 x 5.91 x 4.59)	
Weight	g (lb)	280 (0.65)	
Enclosure		IP 20	
Agency approvals and compliance		CE, UL508, CSA 22.2-213 Class 1 Division 2	

Characteristics

Technology		CSMA/CD	
Ethernet capability		I/O scanner	I/O scanner and embedded web server
Interfaces		1 10/100BASE-TX interface (RJ 45), RS 485 (RJ 45), RS 232 (DB 9M), mini-DIN (Uni-Telway)	
Connection types		Twisted pair cable	
Power consumption	mA	200 @ 24 VDC	
Maximum range	m (ft)	100 m (328) Ethernet, 10 m (33) TER/AUX port, 16.6 m (50) RS 232 serial, 2.5 m (7.6) Uni-Telway	
LED indicator		RUN, ERR (ERROR), RT/TX	

Description



Mechanical construction

Model		499 NEH 104 10	499 NEH 141 00	499 NOH 105 10
Operating temperature	°C (F)	0 to 60 (32 to 140)		
Relative humidity		10 ... 95% (non-condensing)		
Dimensions (W x H x D)	mm (in)	40 x 125 x 80 (1.57 x 4.92 x 3.15)	47 x 135 x 111 (1.85 x 5.31 x 4.37)	80 x 140 x 85 (3.15 x 5.51 x 3.35)
Weight	g (lb)	530 (1.167)	240 (0.529)	900 (1.982)
Enclosure		IP 30	IP 20	IP 30
Agency approvals and compliance		cUL 1950, FM 3810, FM 3611 Class 1 Division 2, CE, Germanischer Lloyd, IEC 61131-2		

Characteristics

Technology		Ethernet 10 Mbit/s	Ethernet 100 Mbit/s	Ethernet 10 Mbit/s
Interfaces		4 10BASE-T ports with shielded RJ45 connectors	4 100BASE-TX ports with shielded RJ45 connectors	3 10BASE-T ports with shielded RJ45 connectors and 2 10BASE-FL with BFOC (ST) connectors
Connection types		Twisted pair cable		Twisted pair cable and redundant fiber optic ring
Terminal block		1 x 5 pole mountable terminal block		
Operating voltage	VDC	18 to 32 Safe Extra-Low Voltage (SELV)		
Redundancy		Power supply		Power supply and fiber optic ring
Power consumption at 24 VDC	mA	80 typical, 130 maximum	210 typical, 270 maximum	160 typical, 350 maximum
Maximum range	m (ft.)	10BASE-T – 100 (328)	100BASE-TX – 100 (328)	10BASE-T – 100 (328) 10BASE-FL – 3100 (10170)
Number of cascade hubs		4	2	4
Number of hubs in a ring		–		11
Link budget		–		11.5 db for 50/125 and 62.5/125 μm fiber
Fault indicator		One of the two power supplies has failed, permanent fault in hub, faulty link status of at least one TP port, or at least one port has auto-partitioned.		
LED indicator		P1, P2 : power, DA/STAT 1 to DA/STAT 4 : data, collision, segmentation, and link status per port		P1, P2 : power, DA/STAT 1 to DA/STAT 5 : data, collision, segmentation, and link status per port

Description



Mechanical construction

Model		499 NES 181 00	499 NES 171 00	499 NOS 171 00
Operating temperature	°C (F)	0 to 60 (32 to 140)	0 to 55 (32 to 131)	
Relative humidity		10 ... 95% (non-condensing)		
Dimensions (W x H x D)	mm (in)	47 x 135 x 111 (1.85 x 5.31 x 4.37)	110 x 131 x 111 (4.3 x 5.2 x 4.4)	
Weight	g (lb)	230 (0.507)	850 (1.87)	
Enclosure		IP 20		
Agency approvals and compliance		cUL 1950, cUL 508, cUL1604 Class 1 Division 2, CE, Germanischer Lloyd, IEC 61131-2		

Characteristics

Technology		Ethernet 10/100 Mbit/s		
Interfaces		8 10BASE-T/100BASE-TX ports with shielded RJ45 connectors	5 10BASE-T/100BASE-TX ports with shielded RJ45 connectors and 2 100BASE-TX ports with shielded RJ45 connectors	5 10BASE-T/100BASE-TX ports with shielded RJ45 connectors and 2 100BASE-FX ports with SC fiber optic connectors
Connection types		Twisted pair cable		Twisted pair cable and redundant fiber optic ring
Terminal block		1 x 5 pole mountable terminal block		
Operating voltage	VDC	18 to 32 Safe Extra-Low Voltage (SELV)		
Redundancy		Power supply	Power supply and copper or fiber optic ring	
Power consumption at 24 VDC	mA	125 typical, 290 maximum	800 maximum	
Maximum range	m (ft)	100 (328)	100 (328)	100BASE-TX – 100 (328) 100BASE-FX – 3100 (10170)
Number of hubs in a ring		–	50	50
Link budget		–		8 db for 50/125 μm fiber 11 db for 62.5/125 μm fiber
Fault indicator		One of the two power supplies has failed, permanent fault in switch, faulty link status of at least one TP port, or at least one port has auto-partitioned.	One of the two power supplies has failed, permanent fault in switch, faulty link status of at least one TP port, at least one port has auto-partitioned, self-test error, or ring monitoring not possible.	
LED indicator		P1, P2 : power, DA/STAT 1 to DA/STAT 8 : data, collision, segmentation, and link status per port	P1, P2 : power, port 1 to 7 status, redundancy manager, and standby	

Description



Mechanical construction

Model		499 NTR 100 10	499 NTR 101 00
Operating temperature	°C (F)	0 to 60 (32 to 140)	
Relative humidity		10 ... 95% (non-condensing)	
Dimensions (W x H x D)	mm (in)	40 x 134 x 80 (1.7 x 5.28 x 3.35)	47 x 135 x 111 (1.9 x 5.3 x 4.4)
Weight	g (lb)	520 (1.15)	230 (0.51)
Enclosure		IP 30	IP 20
Agency approvals and compliance		cUL 1950, FM 3810, FM 3611 Class 1 Division 2, CE, Germanischer Lloyd, IEC 61131-2	cUL 1950, cUL 508, cUL 1604 Class 1 Division 2, CE, Germanischer Lloyd, IEC 61131-2

Characteristics

Technology		Ethernet 10 Mbit/s	Ethernet 100 Mbit/s
Interfaces		1 10BASE-T port with shielded RJ45 connector and 1 10BASE-FL port with BFOC (ST) connector.	1 100BASE-TX port with shielded RJ45 connector and 1 100BASE-FX port with SC connector
Connection types		Twisted pair cable and fiber optic cable	
Terminal block		1 x 5 pole mountable terminal block	
Operating voltage	VDC	18 to 32 Safe Extra-Low Voltage (SELV)	
Redundancy		Power supply	
Power consumption at 24 VDC	mA	80 typical, 100 maximum	160 typical, 190 maximum
Maximum range	m (ft)	10BASE-T 100 (328) 10BASE-FL 3100 (10170)	100BASE-TX 100 (328) 100BASE-FX 3100 (10170)
Link budget		11.5 db for 50/125 and 62.5/125 μm fiber	8 db for 50/125 μm fiber 11 db for 62.5/125 μm fiber
Fault indicator		One of the two power supplies has failed, permanent fault in transceiver, faulty link status on TP port or FO port.	
LED indicator		P1, P2 : power, DA STAT 1 status and DA STAT 2 status.	

Description



Mechanical construction

Model		174 CEV 200 30	174 CEV 300 10
Operating temperature	0 C (F)	0 to 50 (32 to 122)	0 to 60 (32 to 140)
Relative humidity		10 to 95% (non-condensing)	20 to 90% (non-condensing)
Dimensions (W x H x D)	mm (in)	122 x 229 x 248 (4.8 x 9 x 9.8)	35 x 95 x 60 (1.4 x 3.7 x 2.4)
Weight	g (lb)	4263 (9.4)	500 (1.0)
Enclosure		IP 20	
Agency approvals and compliance		UL, CSA, CE	

Characteristics

Technology		Ethernet 10 Mbit/s	
Interfaces		1 10BASE-T, 10BASE-2, AUI port; 1 single/dual cable Modbus Plus port	1 10BASE-T port with shielded RJ45 connector and 1 Serial RS-232/RS-485 port with RJ45 connector
Connection types		1 RJ45, AUI, BNC Ethernet cable; 1/2 DB-9S Modbus Plus cables	Twisted-pair cable
Operating voltage		110/220 VAC (-15% / 10%), 47 to 63 Hz	24 VDC
Redundancy		–	Power supply
Power consumption at 24 VDC		1 A typical	125 mA maximum
Maximum range	M (ft)	10BASE-T 100 (328) 10BASE-2 100 (328) 10BASE-5 100 (328) Modbus Plus 450 (1500)	10BASE-T 100 (328)

Description



Electrical cables

Model	490 NTW 000 xx	490 NTC 000 xx
Cable type	Shielded and foiled twisted pair straight-through cable	Shielded and foiled twisted pair crossed cable
Available cable lengths	m (ft) 2, 5, 12, 40, 80 (6.5, 16.4, 39.4, 131.2, 262.4)	5, 15, 40, 80 (16.4, 49.2, 131.2, 262.4)
Pre-assembled connector type	RJ45 (two per cable)	
Agency approvals and compliance	UL, CSA 22.1 and NFPA 70 approval indicated by "U" after part number (example : 490 NTW 000 40U); category 5 of international cabling standard EIA/TIA-568; Class D of IEC 11801 / EN50173; Low Smoke Zero Halogen (LSZH); flame retardant of NFC32 070 #1 (C2) and CEI 322/1	



Optical cables

Model	490 NOC 000 05	490 NOT 000 05	490 NOR 000 05
Cable type	Standard glass fiber optic		
Available cable lengths	m (ft) 5 (16.4)		
Pre-assembled connector type	MT/RJ-SC duplex	MT/RT-ST duplex	MT/RJ-MT/RJ duplex
Radiation susceptibility	No radiation along the cable		

Description

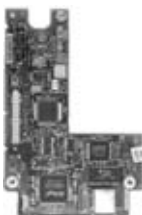

Mechanical construction

Model		VW3A58310U
Operating temperature	°C (F)	-10 to 50 (14 to 122)
Relative humidity		0 ... 95% (non-condensing)
Dimensions (W x H x D)	mm (in)	101.6 x 152.4 x 12.7 (4.0 x 6.0 x 0.5)
Enclosure		Determined by the drive
Agency approvals and compliance		UL 508c, CSA 22.2, No. 14, CE, NEMA ICS, NFPA, IEC and ISO9001

Characteristics

Technology		Ethernet 10/100 Mbit/s
Interfaces		1 10BASE-T ports with shielded RJ45 connectors
Connection types		Twisted pair cable
Maximum range	m (ft)	10BASE-T/100BASE-TX – 100 (328)
Fault indicator		Provided by the drive
LED indicator		Collision Detected, Data Transmit, Data Receive, 10 Mbit/s, 100 Mbit/s

Description



Mechanical construction

Model		CM4000
Operating temperature	°C (F)	-20 to 70 (-4 to 158)
Relative humidity		5 ... 95% (non condensing)
Dimensions (W x H x D)	mm (in)	231.4 x 202.9 x 133.1 (9.11 x 7.99 x 5.24)
Weight	g (lb.)	1900 (4.2)
Enclosure		IP 20
Agency approvals and compliance		UL 508, CSA 22.2-2-4-M1987, CE (EN61010)

Characteristics

Technology		Ethernet 10/100 Mbit/s
Interfaces		8 10BASE-T/100BASE-TX ports with shielded RJ 45 connectors
Connection types		Twisted pair cable
Terminal block		1 x 3 pole mountable terminal block
Operating voltage		90 – 305 VAC or 100 – 300 VDC
Power consumption		50 mA at 90 – 305 VAC, 30 W at 100 – 300 VDC
Maximum range	m (ft)	100 (328)
LED indicator		RS 485 (COM1) TX, RX; RS-232 (COM2) TX, RX; power; maintenance

Description



Mechanical construction

Model	EGX200	EGX400
Operating temperature	°C (F) -30 to 80 (-22 to 176)	
Relative humidity	5 ... 95% (non condensing)	
Dimensions (W x H x D)	mm (in) 200.2 x 122.2 x 27.2 (7.88 x 4.81 x 1.07)	
Weight	g (lb.) 680 (1.5)	
Enclosure	IP 20	
Agency approvals and compliance	UL 508, cUL (complies with CSA 22.2, #14-M91)CE	

Characteristics

Technology	Ethernet 10/100 Mbit/s	
Interfaces	1 10BASE-T port with shielded RJ 45 connector and 1 10BASE-FL port with BFOC (ST) connector.	1 100BASE-TX port with shielded RJ 45 connector and 1 100BASE-FX port with SC connector
Connection types	Twisted pair cable and fiber optic cable	
Terminal block	1 x 5 pole mountable terminal block	
Operating voltage	VDC	21.6 to 26.4
Redundancy	Power supply	
Power consumption	mA	300 maximum at 24 VDC
Maximum range	m (ft)	10BASE-T 100 (328) 10BASE-FL 3100 (10170)
LED indicator	Ethernet LK, TX, RX; Power; COM1 TX, RX; COM2 TX, RX; RS 485	
Technology	Ethernet 10/100 Mbit/s	



171 CCC980 30



170 ENT 110 0



499 NEH 104 10



499 NES 171 00



499 NTR 100 10

References

Memory	Communication ports	Clock speed	Reference	Weight kg (lb)
512 K	1 Ethernet, 1 I/O bus	50 MHz	171 CCC 960 20	0.043 (0.0938)
512 K, IEC Exec	1 Ethernet, 1 Modbus	50 MHz	171 CCC 980 20	0.043 (0.0938)
1 Mb	1 Ethernet, 1 I/O bus	50 MHz	171 CCC 960 30	0.043 (0.0938)
1 Mb, IEC Exec	1 Ethernet, 1 Modbus	50 MHz	171 CCC 980 30	0.043 (0.0938)

Description	Reference	Weight kg (lb)
Ethernet TCP/IP Communication adapter – Basic	170 ENT 110 00	0.043 (0.0938)
Ethernet TCP/IP Communication adapter – Enhanced	170 ENT 110 01	0.043 (0.0938)

Hubs

Description	Reference	Weight kg (lb)
Ethernet Hub 10 Mbps, 4 10BASE-T ports	499 NEH 104 10	0.530 (1.167)
Ethernet Hub 10 Mbps, 3 10BASE-T ports, 2 10BASE-FL port	499 NOH 105 10	0.900 (1.982)
Ethernet Hub 100 Mbps, 4 100BASE-TX ports	499 NEH 141 00	0.240 (0.529)
Ethernet Hub 10 Mbps, 4 10BASE-T ports	499 NEH 104 10	0.530

Switches

Description	Reference	Weight kg (lb)
Ethernet Switch 10/100 Mbps, 7 100BASE-TX ports	499 NES 171 00	0.850 (1.87)
Ethernet Switch 10/100 Mbps, 5 100BASE-TX ports, 2 100BASE-FX ports	499 NOS 171 00	0.850 (1.87)
Ethernet Switch 10/100 Mbps, 8 100BASE-TX ports	499 NES 181 00	0.230 (0.507)

Transceivers

Description	Reference	Weight kg (lb)
Ethernet Transceiver 10 Mbps, 1 10BASE-T port, 1 10BASE-FL port	499 NTR 100 10	0.520 (1.15)
Ethernet Transceiver 100 Mbps, 1 100BASE-TX port, 1 100BASE-FX port	499 NTR 101 00	0.230 (0.507)



174 CEV 300 10



490 NTW 000 ●●



490 NOC 000 05



140 NOE 771 11



TSX ETY 510 2

References (continued)

Bridges

Description	Reference	Weight kg (lb.)
Modbus Plus to Ethernet Bridge	174 CEV 200 30	4.263 (9.4)
Modbus to Ethernet Bridge	174 CEV 300 10	0.500 (1.0)

CE Approved cables

Description	Length m (ft)	Reference	Weight kg (lb.)
Shielded and foiled twisted pair cable	2 (6.5)	490 NTW 000 02	–
	5 (16.4)	490 NTW 000 05	–
	12 (39.3)	490 NTW 000 12	–
	40 (131.2)	490 NTW 000 40	–
	80 (262.4)	490 NTW 000 80	–
Shielded and foiled twisted crossed over cable	5 (16.4)	490 NTC 000 05	–
	15(9.2)	490 NTC 000 15	–
	40 (131.2)	490 NTC 000 40	–
	80 (262.4)	490 NTC 000 80	–
Fiber optic cable, MT/RJ-SC Duplex connectors	5 (16.4)	490 NOC 000 05	–
Fiber optic cable, MT/RJ-ST connectors	5 (16.4)	490 NOT 000 05	–
Fiber optic cable, MT/RJ-MT/RJ connectors	5 (16.4)	490 NOR 000 05	–

UL and CSA approved cables

Description	Length m (ft)	Reference	Weight kg (lb.)
Shielded and foiled twisted pair cable	2 (6.5)	490 NTW 000 02U	–
	5 (16.4)	490 NTW 000 05U	–
	12 (39.3)	490 NTW 000 12U	–
	40 (131.2)	490 NTW 000 40U	–
	80 (262.4)	490 NTW 000 80U	–
Shielded and foiled twisted crossed over cable	5 (16.4)	490 NTC 000 05U	–
	15(9.2)	490 NTC 000 15U	–
	40 (131.2)	490 NTC 000 40U	–
	80 (262.4)	490 NTC 000 80U	–

Platform	Description	Reference	Weight kg (lb.)
Quantum	TCP/IP Ethernet module with I/O Scanner	140 NOE 771 00	0.345 (0.76)
	TCP/IP Ethernet module with Embedded Web Server	140 NOE 771 10	0.345 (0.76)
	TCP/IP Ethernet module with I/O Scanner	140 NOE 771 01	0.345 (0.76)
	TCP/IP Ethernet module with Embedded Web Server	140 NOE 771 11	0.345 (0.76)
Premium	TCP/IP Ethernet module with MODBUS/TCP	TSX ETY 110	0.370 (0.8)
	TCP/IP Ethernet module with Embedded Web Server	TSX ETY 110 WS	0.370 (0.8)
	TCP/IP Ethernet module with Warm Standby	TSX ETY 210	0.370 (0.8)
	TCP/IP Ethernet module with I/O Scanner	TSX ETY 4102	0.370 (0.8)
	TCP/IP Ethernet module with Embedded Web Server	TSX ETY 5102	0.370 (0.8)
	TCP/IP Ethernet CPU with Embedded Web Server	TSX P57 2623M	0.56 (1.233)
	TCP/IP Ethernet CPU with Embedded Web Server	TSX P57 2823M	0.56 (1.233)
	TCP/IP Ethernet CPU with Embedded Web Server	TSX P57 3623M	0.56 (1.233)
	TCP/IP Ethernet CPU with Embedded Web Server	TSX P57 4823M	0.56 (1.233)

Customer Reference Notes

Schneider Electric operates in over 130 countries. Our automation customers include original equipment manufacturers (OEMs), who use our products in their equipment and systems. Our customers include both the end users of our products, who often specify Schneider Electric in their orders for new equipment, and the manufacturers who directly specify our products.

The application of Internet and Ethernet technologies on the factory floor has been nothing short of revolutionary. Schneider Electric's Automation Business is proud to have pioneered the use of these revolutionary technologies in the automation industry with Transparent Factory®.

Read on and discover examples of how Transparent Factory is helping Schneider Automation customers be more productive, cost-efficient and competitive.



Manufacturing Great Dane



Status Quo

Great Dane's North American manufacturing plants are located in Georgia, Tennessee, Indiana, Nebraska, Illinois and Mississippi. Motion engineering headquarters are in Savannah, Georgia, making for long trips to the outlying plants.

The plants lacked qualified technicians who could address complex motion control issues, forcing them to rely heavily on their Savannah-based motion engineers. For many years, the plants used identical motion control systems based on traditional architecture, separate motion controllers, and an existing automation platform. Neither motion suppliers nor their motion engineers had remote access to the equipment.

A motion-related problem at any of these facilities had a significant impact on operations, as downtime accumulated during hours of "blind" troubleshooting over the telephone. Particularly serious problems required emergency travel while unrecoverable manufacturing time slipped away. Even incremental process improvements were problematic because they required costly, time-consuming travel by a limited staff.

It was clear Great Dane had a variety of challenges. They had been unable to identify a practical wide-area engineering solution, until they learned of Schneider Electric's motion control system integrated into a full-featured programmable logic controller (PLC) platform.

Status Quo (continued)

Schneider Electric's web-based solution provides Great Dane Trailer Truck Company with easy access to their control network while maintaining maximum security. The Schneider solution does all this WITHOUT additional support software and WITH only minimal training. The key to the solution is the "openness" of the system architecture. This openness allows Great Dane to leverage significant benefits from Internet and TCP/IP technology.

Wide-area engineering

Great Dane installed Modicon Telemecanique Quantum PLCs and SERCOS-compliant Lexium® Servo drives to create a motion system that was a natural extension of the existing automation platform. With a Modicon Sercos module added to the PLC, Great Dane's servo drive system integrates motion control into the PLC architecture.

The system's programming software, working in tandem with an Modicon Motion Framework (MMF) Start library, made programming complex motion profiles as easy as configuring and arranging graphical "movement" function blocks. This architecture simplified development and diagnostics as motion and automation programming were merged into a single application program for each PLC.

To get the most from their new open architecture, Great Dane augmented the new motion control system with Schneider's Transparent Factory® technology. Web servers within the PLCs tie into Great Dane's existing Ethernet-based Intranet. That interface allows them to use any Web connection to diagnose the cause of system failures at any plant, and to get the plant running again in record time. The system allows Great Dane to monitor processes for red flags, pre-empt downtime and adjust motion profiles and machine sequences easily and instantly.

Using a wireless Ethernet card to dial into an Internet service provider and then into the plants over Ethernet speeds transmissions that once moved more slowly through modems and over telephone lines. Remote access for diagnostics and data collection has proven invaluable to Great Dane.

Seamless integration

The concept of transparency applies not just to remote monitoring but also to system integration. Open component hardware and software products allow seamless integration with equipment from different suppliers. For example, bridges from several vendors can be used to connect older machines to Ethernet.

Using an open Ethernet network is a nice fit for plants that have no common manufacturing network, but whose Intranet provides an existing fiber backbone. Great Dane already had an existing Token Ring network for their office systems. Like Ethernet, Token Ring is a Modbus TCP/IP network, but in order to bridge the two networks and allow them to "see" each other, a router was installed.

The open nature of Schneider's solution allowed Great Dane to use the existing wire and cable structure to collect manufacturing data through a common secondary protocol, Modbus TCP/IP. Plant floor data now runs through an OPC server to office systems, where it can be monitored and archived.

By basing the system on standard, off-the-shelf hardware and software that was already in place with the current office network, Great Dane avoided having to purchase special routers, bridges, switches, hubs and cables. Costs were contained by eliminating the need to buy, maintain, and repair new equipment.

Transparent Factory allows Great Dane to use the existing Ethernet firewall to monitor and control access to their manufacturing operation. They can also use existing industrial switches to control network traffic. Switching Ethernet traffic off their Intranet avoids delays that result from too much communication over our Ethernet cable. As switches have become more affordable, Ethernet has become cost effective for industrial control.

Web-enabled motion control provides Great Dane with a wide-area engineering network that saves time and money. It's a unique capability that's relatively simple to implement and undeniably practical. It is a long-term solution that works





Automotive Ford Motor Company



The solution

Ford Motor Company's Sharonville, Ohio, plant chose Schneider Electric to provide a unique, low-cost, open-architecture material call system for a transmission gearset assembly line.

Working on the new Model 4F27E automatic transmission for the 2000 Ford Focus™, the PLC-based material call system permits operators on the assembly line to quickly and reliably call for pallet-loads of gearset components.

This Transparent Factory® solution uses 23 Momentum CPUs with Seriplex™ distributed input/output bases that serve material call pushbuttons and pilotlights. Rather than individual channels, each base has an open Seriplex device-level network for the input/output function.

For the controller, there is one distributed input/output base fitted with a processor adapter that serves as the system PLC. The processor adapter also includes an integral Ethernet communications port and an optional Modbus Plus® communications port.

For the network, special Ethernet communication adapters on the 23 Seriplex input/output bases serve as the input/output. An open 10BaseT TCP/IP network with Modbus® open data representation links the PL base to the input/output bases.

The project was relatively inexpensive because a full size PLC was not necessary. The network could be piggybacked on an existing plant Ethernet backbone. Conventional field-device parallel wiring and input/output module channels were eliminated.

Transparent Factory

Ford picks Schneider Electric
for a material call system



Picking gerset components

Pushbuttons call for parts

The material call system alerts forklift drivers to deliver pallets of parts to 27 locations along the automated gerset assembly line. At each location, an operator can call for a replacement pallet by pushing an illuminated button that is mounted on, or close to, a nearby assembly machine control cabinet.

Each illuminated button is connected to a short run of Seriplex cable wired back to a Momentum Seriplex field input/output base. The compact base and its power supply are mounted on the inside of the control cabinet door to simplify installation. The Momentum Ethernet adapter snaps into the Seriplex base and one of four existing Category 5 Ethernet cables in the cabinet connects to the adapter. Of the three other Ethernet cables available in each cabinet, one networks Quantum controllers running the assembly machines, and another is for PC-based HMIs. The remaining cable is a spare.

The Ethernet cable from the Momentum Seriplex base connects to one of six existing roof beam-mounted Ethernet intermediate distribution facilities (IDFs). Each IDF in turn is linked to a main distribution facility (MDF) in a computer room near the center of the plant. The Momentum input/output base/processor adapter unit that serves as the PLC is also located in the computer room and is likewise connected to the MDF. The plant's Ethernet backbone consists of a combination of fiber optic and Category 5 cables, depending on the distances covered.

Fast response

Each call system pushbutton is individually addressed by the PLC. Communications with the input/output over Ethernet is through direct mapping of references (cyclic data exchange), allowing all 23 input/output bases to be serviced in a single PLC scan. This Peer Cop Ethernet architecture, coupled with the bit level architecture of Seriplex, makes for fast, real time response.

When the controller notes the closing of a pushbutton, it pushes the address to a PC-based OPC factory server via a 1.0 Mbps Modbus Plus RS485 link. The server matches the address to a lineside location, part number, part description, pallet storage location, date, and time. This information is forwarded to a plantwide, minicomputer-based Ford Smart database server to request a new pallet. At the same time, the OPC factory server issues a signal to the PLC to turn on the pushbutton's confirmation light to inform the operator that the parts request has been received. Response is about 1/8 second from button pushing to light activation. There is no need for the line operator to depress the pushbutton until the confirmation light appears.

The SMART Server sends a signal via the OPC factory server to a PC that prints a picking-ticket in the parts storage area. A call request is then displayed on a touch screen. The forklift driver acknowledges the request, which erases the request from the display and prints a picking ticket. The driver's action is also relayed back to the PLC, which turns off the confirmation light to indicate that parts are on the way. To eliminate the need for the driver to constantly check the monitor for requests, the PLC also flashes multiple overhead beacons via Seriplex relays as parts requests are posted and acknowledged on the monitor. The beacons can be seen from anywhere in the Gear Department.

Transparent Factory

Ford picks Schneider Electric
for a material call system



Line operator activates pushbutton

Useful in other plants, application

The material call system's architecture is flexible and can be used anywhere that parts must be delivered to a machining or assembly line. The relative contributions of the Ethernet and Seriplex communications technologies can easily be varied. In an engine plant, for instance, overhead conveyors may permit the low-level Seriplex cable to run along rails and thereby serve as the backbone of the system.

Plants with fieldbus communications other than Ethernet, such as Modbus Plus, FIPIO, Interbus, and Profibus DP, could also be mated to the Seriplex I/O bases.

Sharonville's hybrid Ethernet/Seriplex call system was implemented quickly and has proved rugged and reliable. Programming the system was accomplished by a Ford engineer in less than two days because basic material call system software was already available and could be configured and mapped to suit the Sharonville application. Seriplex is easy to use, and its single four-wire cable means adding or moving button boxes is also easy.

This new material call system fit nicely into an existing facility where control cabinet space is at a premium. It also makes use of the plant's existing investment in communications, control, and computer equipment, which reduced the cost of implementing and bringing the system on line.

Transparent Factory

Hooper Engineering says, Schneider solution lets them "see through the walls"



Packaging Hooper Engineering



Remote monitoring of processing operations

When Hooper Engineering told Schneider Electric they wanted the ability to "see through walls" from a central control room or remote computer, Schneider responded with a customized Transparent Factory® solution. The solution enables Hooper to prevent machinery breakdowns, respond to glitches practically in real time and manage energy costs more shrewdly.

To Hooper Engineering customers who package food, pharmaceuticals or medical devices, being able to remotely monitor an environmentally controlled processing operation is extremely valuable.

Sarasota, Florida-based Hooper Engineering uses Schneider technology in the newest version of its N2500 packaging machine. The machine is designed to package convenience foods, medical supplies and consumer products.

Transparent Factory

Hooper Engineering says, Schneider solution lets them "see through the walls"

A nice neat package

Hooper Engineering touts the NC2500 as the world's first Web-enabled packaging machine. It integrates a Schneider Electric Premium PLC with an embedded Web server. The result gives an OEM and its customer Transparent Factory capabilities for programming the machine, reducing system downtime, troubleshooting and accessing real-time production data.

Transparent Factory is Schneider's open automation strategy that combines the universal and open Modbus TCP/IP Internet protocol with a web server embedded in the PLC. This vendor-neutral architecture allows a company to easily transmit factory floor data to its business systems. It also allows the user to remotely perform remote diagnostics on a single machine or an entire production operation.

Hooper Engineering's N2500 forms product holding pockets from roll stock such as formable film, foil, paper or synthetic protective material. The machine has a loading area where the product is placed in the pockets manually or by pick-and-place machines. The machine covers the pockets with a top sheet of film, then seals the pocket using heat and pressure. Automatic knives then cut the pockets into individual packages. Hooper's equipment allows adjustable index lengths and package widths, reducing material waste and enabling a single machine to package products of different sizes.

Affordable real-time access

"Although the machine has been automated for some time, it's the integration of the Web server in the PLC that makes remote data collection economically feasible," said Hooper Engineering's Michael Wilmshurst. The Web-enabled controller lets packagers with Internet access monitor the machine's performance from anywhere, determining if the machine is on or off, how many pieces it is producing, how many cycles it is running and how efficiently it is operating. "Web-enabled automation gives our customers distinct benefits," he explained. "They have access to information they couldn't get in a timely way before and it helps them use that information in a more efficient manner. The most important benefit is that the PLC's built-in web pages allow performance data to be viewed by everyone in the organization, without any additional software," Wilmshurst added. Wilmshurst said web-enabled control also means safer and more flexible work conditions, because machines can be monitored and in some cases maintained remotely.

Maximizing "up time"

The ability to monitor machine performance remotely is critical for Hooper customers. "We can assist them on-line in the case of a stoppage. For example, if a sensor has been knocked out of position we can assist in realigning it," Wilmshurst said. Remote access also benefits Hooper customers who maintain modified atmospheres in their plants. For instance, packaging of pharmaceutical and medical devices takes place in so-called "clean" rooms, while food packaging often takes place in "cold" rooms. In either case, being able to diagnose system status remotely helps maintain the atmosphere.

Controlling programming costs

Wilmshurst said Schneider's Transparent Factory architecture also helps control the costs of machine data integration into plantwide supervisory control and data acquisition systems. This is accomplished by providing the data in an open format. "All the information the customer needs to control the equipment can be accessed using the web browser already built into his PC," said Wilmshurst. "There's no need to call in high level programmers – just go in and build a little PCML (Program Call Markup Language) screen and the basics are already there. Our customers can usually perform their own enhancements very quickly. We can give them the first course of building blocks, then they build onto their system as they like," he added. The web-enabled Hooper packaging machines can also be linked into the common database from a customer's other facilities.

Simplified motion control

Another advantage of the Schneider Electric PLC is built-in motion control programming software that allows the Hooper machine to simulate, validate and manage a number of packaging operations along a range of axes. The pre-programmed motion software manages Schneider's servo drive system. These application-specific routines enable a wide variety of sophisticated multi-axis packaging operations. By integrating hardware and software functions, including motion control and loop control, Schneider has enabled Hooper Engineering and its customers to shorten application development and start-up time by several months.

"The software, using modular function blocks in a single programming package, simplifies system design and replication," Wilmshurst said. "A common user interface is employed for entering and adjusting parameters and performing diagnostics, which makes programming easier for everyone on the project design team," he explained.

Easy maintenance

When downtime occurs, or in preparation for scheduled maintenance, the Premium PLC also provides a hyperlink to the operator manual for the machine. From there, embedded Web pages including the N2500's actual Auto CAD drawings in PDF format can be read from the customer's PC.

Web-enabled automation technology from Schneider Electric is now part of the N2500's standard offering. "Sometimes an application is simply a matter of fulfilling the customer's specifications," said Wilmshurst. "Other times, they tell us what they want to do but don't know how to do it. We tell them there's an excellent controller that allows us to slip an embedded web module into the rack. Our customers have been quick to recognize the advantages of that capability."



Food and beverage Bethel Grain



Intelligent motor control center

The goal is optimized productivity

When Bethel Grain Company in Benton, Illinois decided to diversify into a new market that required the company's first automated production line, they turned to Schneider Electric for a fast-track solution. That solution, a web-enabled multi-network OMNI Motor Control Center, allowed Bethel Grain to take a quick first step toward becoming a fully integrated, Transparent Factory®.

Bethel Grain moves fast. The company grew rapidly from its start in 1997, expanding from 30 to 70 employees in two years. It buys dry grain from nearby farms in southern Illinois, grinds it into meals and flours, then processes it into food ingredients. Initially, the business focused entirely on supplying U.S. government contracts for a corn-soy meal blend used for foreign food aid. Bethel Grain made its mark quickly, winning the United States Department of Agriculture's 1999 award as Commodity Operation Small Business of the Year.

The thriving young company had its sights set on diversifying to grow its business domestically. To enter the market for breakfast cereal ingredients, Bethel Grain needed to expand. Specifically, they needed a new hammer mill to grind corn meal and an extruder to modify it into pre-gelatinized corn flour. With quality control the top priority, Bethel Grain sought out an intelligent motor control system that would help improve process performance and allow optimum in-line processing control.

Consulting engineers advised Bethel Grain on conceptual electrical layout and design and later handled software programming. But it was Bethel Grain's own engineers who zeroed in on a supplier. They saw a Schneider Electric OMNI Motor Control Center at work in a colleague's North Carolina mill, liked the layout and contacted Schneider Electric about a system to fit their own needs.

Transparent Factory

Web-enabled MCC moves Grain mill into new market

Teamwork is the key

Working out of his St. Louis office, Schneider Electric Field Engineer John Maue became the liaison between the consultants and the engineers at the motor control center manufacturing plant in Seneca, S.C. He supplied data to the engineering team at the plant, enabling them to expedite the order to fit a tight deadline.

"There was a consensus that Schneider Electric could provide a rugged, reliable solution that was customized but wasn't over-engineered," said Brian Anderson, Bethel Grain's operations director. "The OMNI Center was pre-wired, assembled and tested at the factory and came in as a complete unit," Anderson said. "We could bolt it to the floor and get it going right away."

Transparent Factory at work

The Omni Center for Bethel Grain embodies what Schneider Electric calls its Transparent Factory automation architecture. It combines a versatile, scalable and widespread physical network with a universal networking standard and a vendor-neutral data protocol. The result is a truly open, Web-accessible network for the exchange of process data between the factory floor and the company's business systems.

The Schneider solution supports a TCP/IP-compatible Ethernet backbone and boasts best in-class products from three Schneider Electric master brands including Modicon, Telemecanique and Square D. The web-enabled Modicon Telemecanique Quantum PLC communicates and controls the Square D Altivar 66 AC drives, remote analog and digital input/output, and the Motorlogic Plus solid state overload relays. The system gives Bethel Grain technicians real-time information on current loading, voltage, power factor, trip indication and history, as well as thermal capacity and ground fault through the system's Schneider's MonitorPro SCADA software.

"The advanced protection we get through the Motorlogic Plus relay simplifies preventive maintenance, which is real important to us. Maintaining a consistent process flow is critical," Anderson said. "The system also helps us be more productive because we can detect and correct process problems before they become serious."

Schneider's Concept programming software inside the Quantum PLC tells the motor starters when to turn on and turn off. The software provides easy-to-use interfaces, power search functions, and on-line help that simplifies writing, documenting and maintaining Bethel Grain's control system.

The Quantum PLC is connected to color graphic terminals that display process data on a control room PC. The system also uses MonitorPro software to retrieve the data and display it on the monitor.

Transparent Factory

Web-enabled MCC moves Grain mill into new market

Ethernet/TCP/IP key to data access

Besides automating motor control on the plant floor, Ethernet TCP/IP capability built into the Quantum PLC allows Bethel Grain to easily analyze and share process data in real time. Access to that data is available throughout the company over a secure Extranet link, even from offsite PCs and laptops. That kind of instant access is designed to help the company boost its processing uptime and, ultimately, its bottom line.

Designing, manufacturing, delivering, and installing the system within a few short months presented challenges that Schneider Electric met. Engineers designed the system based on raw data from the customer and Schneider Electric representatives, without the usual detailed layout from a consulting engineer.

"Instead of a consulting engineer providing detailed specifications to the plant, our engineers in Seneca had to do it," said Schneider Electric's Maue. "The timing factor further complicated the task of supplying a large, complex lineup. The engineers at the plant played key roles and really performed like heroes to get the job done."

Up and running fast

Schneider Electric got the OMNI Center up and running on schedule. It's an upgrade Bethel Grain needed to remain competitive and to grow. In terms of sound capital investment, Anderson said the web-enabled Omni Center already adds value, with the flexibility to help Bethel easily move forward toward full integration in the future.

"This system is working out for us," Anderson said. "Anytime you automate, it will really help with quality control and give you much more in-line processing control. That helps us achieve the diversification we need for the company's long-term stability."

In choosing the Omni Motor Control Center, Bethel Grain found a custom-designed solution. Quick delivery and installation time added value to their choice. Equipped with an automated production line augmented with an Ethernet TCP/IP open architecture network, Bethel Grain is a better, stronger mill. It is a "Transparent Factory" poised for continued success.

Transparent Factory

Schneider Electric solution is the right recipe for a South African brewery upgrade



SOUTH AFRICA

Food and beverage South Africa breweries



Introduction

The South African Breweries (SAB) is one of the largest breweries in the world. Their facility in Chamdor, Gauteng, South Africa was in need of an upgrade. E'nI Projects, an authorized System Integrator for Schneider Automation South Africa, was contracted by SAB for the job. The brew-houses were controlled by Modicon 984 PLCs and a proprietary DOS-based sequence control software system called Magus. The project covered malt intake, silo block, malt conveying, milling and the brew-houses. The Magus system was the logic sequence controller executing the recipe-based control and management of the brewing process. The PLC system consists of three Modicon 984-785E CPU's, was used for the plant input/output control. The PLCs were running Modsoft programs which were only used for register transfers to and from the Magus system.

The Magus system was not Y2K compliant and was only supported by one vendor in the country. Maintenance had become extremely difficult for the SAB personnel and they were anxious to replace it with a new user-friendly system.

Transparent Factory

Schneider Electric solution is the right recipe for a South African brewery upgrade



The objective

The objective of the project was to implement an open, state-of-the-art control system in order to relieve the client of their dependence on the Magus system and improve plant operation. The client however was reluctant to replace the 984 PLC input/output cards, because of the cost associated with installing new input/output, and also because of the downtime that would result from rewiring new input/output cards. The brewery is a 24 hour operation and the requirement from SAB was to strictly adhere to pre-planned shutdown periods for the implementation of the new control system. The brewery needed a solution that would accommodate a change-over with only a few shutdowns.

The solution

The solution was based on the existing 984 input/output cards but replacing the 785E processors with Quantum processors. The Quantum processors were installed in separate 4 slot racks with remote input/output communication to the existing racks. Modicon's Concept software replaced the Magus sequence logic and controls the plant via the Quantum processors.

A commissioning schedule was drawn up to accommodate the brewery's production requirements. The schedule was made up of a number of short shutdowns to test the new programs section by section. At the end of each commissioning period, the brewery was placed back on the existing control systems. The commissioning periods were done using water brews to test each section of the plant. After final testing on water brews, the plant was placed on full production utilizing the new Quantum processor and Concept software system.

During the testing phases the existing input/output ran using Modbus Plus to connect the new Quantum processor to the existing 984 system. This ensured a quick return path to the existing system after testing because no hardware changes had been made to the existing systems. When final testing was completed, the plant ran from the Quantum processors still using the Modbus Plus / Peer Cop system. This would allow us to rapid return to control the existing system if it became necessary. The plant was run on this system for a one month verification period to ensure the integrity of the new system.

After the verification period the final shutdown involved removing the 984 CPUs and installing the remote input/output communications between the Quantum processor racks and the 984 input/output racks.

Transparent Factory

Schneider Electric solution is the right recipe for a South African brewery upgrade

Food and beverage South Africa breweries (continued)

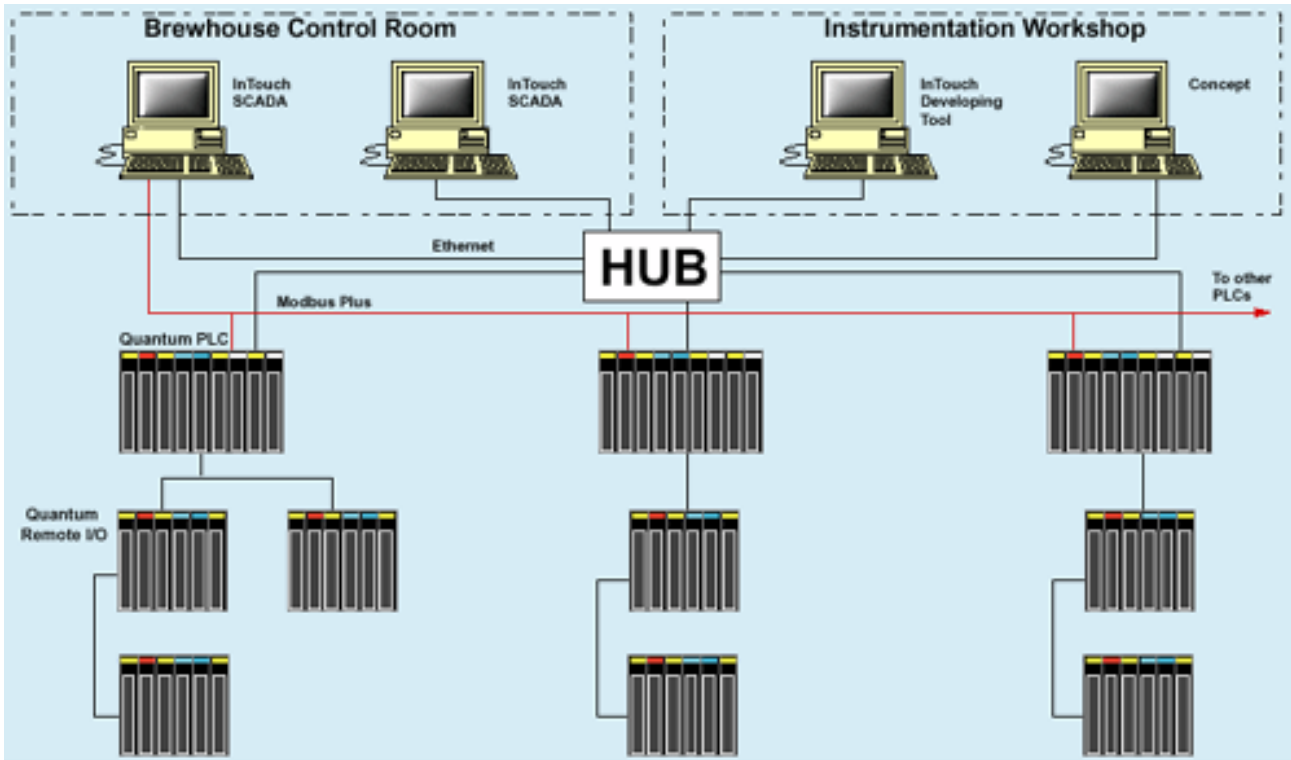

The control architecture for the South African Breweries' Chamdor facility

The benefits

- Y2K compliance
- Removal of the Magus system.
- Vast improvement in plant maintenance from the ease of understanding of the new Concept programs.
- The new Quantum racks were fitted with Ethernet cards and there was a great improvement in the communications to the InTouch SCADA system.
- The Modbus Plus and Ethernet communications effectively provide a redundant communications system.
- Concept software enables internal maintenance and modifications and can now maintain and modify the system internally (i.e. no more dependence on outside software vendors).
- Modifications to the control system are now possible doing very short shutdowns, whereas previously lengthy shutdowns and testing procedures were necessary.
- The new Quantum PLCs support open Ethernet communications for data transfers to an MES system.
- Reliability and production efficiencies have improved significantly.



Pharmaceutical Cargill nutri-products



An issue of connectivity

Cargill's Eddyville, Iowa plant turns out natural Vitamin E from co-products of soybean oil. Cargill Foods soybean processing plants throughout the United States supply feedstock. The plant sells all its output to its pharmaceutical partner, which targets the growing worldwide market for antioxidant vitamins.

When the plant opened in 1997, Cargill Nutri-Products committed to achieving supply chain efficiency and to employing state of the art technology to optimize productivity. Ensuring that this commitment became reality fell, in part, to automation manager Tom Shaw and his four-person team. They contacted Schneider Electric.

One of the team's primary goals was interfacing the plant's power meter and eight heat trace controllers, which were not connected to the plant's distributed control system (DCS). The heat trace controllers use electric heating cables to keep liquid process ingredients from solidifying in piping systems and holding vessels and prevent stagnant water from freezing during winter.

Making the upgrade would eliminate the laborious task of manually recording power data. But to interface devices from different vendors was cost-prohibitive when the plant first opened.

For more than three years, Cargill electricians and engineers took clipboards and pens in hand and trekked around the plant, recording data from its power meter and heat trace controllers. They recorded voltage, current, power factor and energy usage at the meter. At the heat trace controllers they monitored the temperatures of all 40 circuits in each panel. One of Shaw's team would then pour over the heat trace figures and issue work orders if they found problems with circuits. They manually entered power meter data into a spreadsheet for internal billing

Transparent Factory

Now Cargill's talking with Modbus to Ethernet connectivity from Schneider Electric

OPC is the answer

"We were looking for an economical solution," Shaw said. "But when the plant was built, I would have had to do a custom interface because nothing standard existed OPC didn't exist. I'd have had to buy a whole CPU to do what we can now do with OPC software. Just a few mouse clicks collects that data, compiles it into a spreadsheet and feeds it to our data historian for tracking."

Shaw installed OFS (OPC Factory Server) software from Schneider Electric to interface simple Modbus devices. OPC software is designed to provide business applications with common local or remote access to industrial plant floor data. Using the OPC open standard, software and hardware manufacturers, as well as system integrators, will spend less time on communication and database integration issues.

Pushing the envelope

It was our first experiment with OPC and a bit of a gamble to get dissimilar systems talking to each other over OPC. We talked to our Schneider account rep and he said it was doable with the technology I had in mind. From Schneider, we purchased OFS software and Square D Powerlogic[®] circuit monitors and away we went," said Shaw.

Powerlogic is a power quality analysis system that includes power meters, circuit monitors, software and hardware for managing power. In Cargill's application, circuit monitors talk on Ethernet through a gateway. The OPC server seeks out the register values in the power meter, and then serves these Circuit Monitor values up to Cargill's batch control system. The OPC server is essentially a conduit between the two devices. It lets the Circuit Monitor be communicated in a standard format that the DCS can understand.

Bridging Modbus to Ethernet was a key step for Shaw's team. "The uniqueness of our installation comes from the way we communicate with the Modbus devices," Shaw said. "Instead of using a PLC and a Modbus network, we used a simple and inexpensive Modbus-to-Ethernet bridge from Schneider Electric." The bridge converts Modbus to Modbus/TCP, an Ethernet-based network.

Having used the bridge to convert to Modbus/TCP, Shaw's team then connected their equipment using standard Ethernet cabling to an Ethernet switch. "Using the OFS software, we were able to easily configure the Modbus/TCP devices and test the configuration," Shaw explained. "After we completed those steps, the remaining steps were a breeze."

Those steps entailed configuring communication software points in the plant's DCS and using OPC mirror software to pipe the Modbus/TCP registers to the communication software points. "The actual configuration was simple," Shaw said. "When you start the mirror software, the program asks you to define a pipe. We configured the pipe by selecting OFS as the source OPC server and our other server as the destination server."

After completing that step, Shaw's team browsed the Modbus/TCP registers and the communication software point attributes, then dragged and dropped the pipe from the correct Modbus/TCP register to the correct communication software point attribute. Finally, they configured the points in the plant's data historian.

"We could have bought a third party OPC but the comfort factor of working with Schneider Electric trumped all that," said Shaw. "I felt that if we needed any technical help, we could count on Schneider."

With a conservative initial investment, Cargill Nutri-Products now can interface more than 7,000 Modbus/TCP registers. Shaw's team also can enhance the plant's OPC interface at a fraction of the initial investment.

"We had all these devices that communicate via Modbus and expected that if we could use OPC/Ethernet technology to interface them, we could get a wealth of information very inexpensively," Shaw said. "We can just call that information up from our data historian just like the rest of our process data. That's where the real savings is doing with software what we used to need hardware to do. To achieve that in 1997, there wasn't enough money in a bank."



Piping system for liquid process ingredients



Oil & gas - Versatruss Americas LLC

The installation

Versatruss Americas LLC, Belle Chasse, Louisiana, designs and manufactures “one of a kind” offshore heavy lift systems primarily for use in the installation and removal of large offshore oil production facilities. To ensure structural soundness and personnel safety during this installation/ removal process, the object being lifted must be kept level and planar with the barge(s).



The Magelis interface on board a Versatruss lifting barge

The current installation consists of two inclinometers on each barge and lift subject and a wireless Ethernet network. Schneider Electric was chosen by the customer to develop a low-cost method of remotely monitoring the attitude (pitch/roll) of the two barges and lift subject, and to provide a visual interface for the system operator which accurately depicts this information.

The objective

The project objective was to provide a functional control system, operating without downtime, at the least possible cost, installed within a six week time-frame.

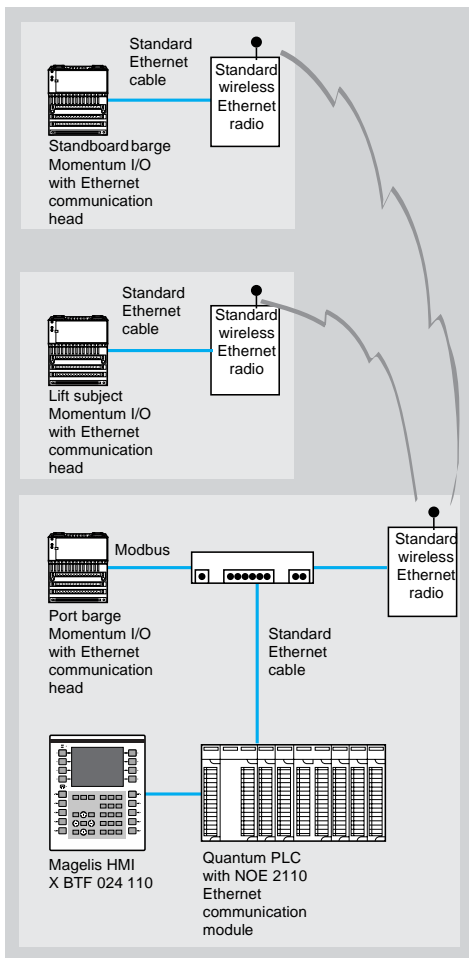

The solution

Designed by Bill Thrift and Jim Lester, Versatruss Americas, LLC; Bill Wang, TEST Inc.; and Steven Wetzel, NU-LITE Electrical Wholesalers, LLC, the Schneider Electric solution includes a Modicon Telemecanique Quantum PLC with three remote Modicon Telemecanique Momentum I/O modules, each equipped with an Ethernet adapter for data collection and a Magelis operator interface.

Pitch and roll data is gathered by each Momentum I/O module, transmitted over the Ethernet network, and read by the Quantum PLC. This data is in turn given to the Magelis HMI to provide the system operator with an accurate and graphical depiction of the attitude at each location.

Customer benefits

- Speed of communications.
- Low cost of each unit.
- High degree of accuracy.
- Ease of upgrading Momentum.



Versatruss America LLC designs and builds offshore heavy lift systems



Australia

Zinc refinery - Sun Metals Corporation



When the Sun Metals zinc refinery decided to embark on the largest investment in Australia by a Korean company, they knew an open architecture control system would need to be implemented, providing constant access to data to minimize downtime and operation costs. The new \$350 million zinc refinery was projected to generate estimated export revenues of \$225 million per year.

Schneider Electric was chosen to supply Modicon Telemecanique Quantum PLCs, including hot standby redundant processors, a Monitor Pro SCADA system, PLC cubicles, control desks and UPS equipment.

The entire Schneider Electric solution includes: design of the communication and control system, development of the PLC and SCADA software, as well as installation and commissioning of the system.

Sun Metals Corporation is a wholly owned subsidiary of Korea Zinc Company Limited, one of the world's largest zinc producers.

Transparent Factory

Sun Metals zinc refinery is "open for business"



The refinery

This particular refining process is modeled after the world's most modern operation that encompasses roasting, leaching, purification, electrolysis, and melting and casting. The plant will use some 400,000 tons per year of zinc concentrate primarily from North West Queensland. Other products generated by the process include sulphuric acid and cadmium (from the purification process).

The refinery is expected to be a catalyst for additional projects in the area, including power generation and other downstream metal product industries.

The control system

System availability is critical for the plant. To offer the high levels of redundancy required, the control system employs hot standby systems on crucial processes and a dual Ethernet and dual fiber optic self-healing ring.

Linked on the dual TCP/IP Ethernet network, the 15 Quantum PLCs control the roasting, gas cleaning sulphuric acid, concentrate leaching, utilities, purification, electrolysis, zinc dust and water treatment processes. There are a total of 6000 input/output points throughout the plant.

In the roasting plants, a Quantum Hot Standby system ensures uninterrupted transfer from one PLC to another (in less than 45 msec) should one PLC fail. The dual Ethernet is linked via hubs to the 100MHz dual fiber optic self-healing ring the communication network for the SCADA system. The system can withstand four breaks without any downtime. For extra durability, dual redundant cabling is used for all remote input/output.

Schneider Electric's Concept PLC programming software uses derived function blocks on repetitive functions such as motor control centers and alarming.

The Quantum Ethernet modules will also allow Sun Metals to monitor the plant from anywhere in the world via the Internet.



Transparent Factory

Pharmaceutical manufacturer meets tough FDA standards with Schneider Electric solution



CANADA

Pharmaceutical - Glaxo Smith-Kline



The existing installation

Glaxo Smith-Kline's new 215,000 sq. ft. product development and manufacturing center located at its Canadian headquarters in Mississauga, Ontario, may well be a world first: a high-rise automated storage retrieval system (AS/RS). This big-league AS/RS serves as a spine for the various production processes and packaging lines, as well as a direct link to the shipping and receiving areas of an FDA-validated manufacturing control system.

Transparent Factory

Pharmaceutical manufacturer meets tough FDA standards with Schneider Electric solution

Keeping things moving

Having 3,400 storage slots, each with 15 height levels of storage, the AS/RS handles loads in all production stages, from raw material to the finished product. Loads enter and exit at various levels along the sides, not at pick-up and delivery points at the ends. Raw materials arriving on wooden pallets are transferred to dedicated aluminum pallets. The repalletized loads are deposited onto a chain-drive pallet roller conveyor, and travel to a sizing station. From here, loads pass through an automated door and into the AS/RS. In the AS/RS section, two cranes capable of traveling 600 ft. per min. horizontally and 200 ft. per min. vertically patrol the aisles, one on each side of the back-to-back racks. Storage within the AS/RS is random, but zoned. A nightly optimization program shifts loads around so they will be in the best position for the next day's production.

The objective

Production activities and support operations occur on five levels in various "suites" located in the building surrounding the AS/RS. Communications between each area and the AS/RS is critical. Glaxo Smith-Kline required a fully automated PLC system for storage and retrieval of material, as well as a fully integrated suite of software packages to control manufacturing procedures. The project was also driven by the need for efficiency, productivity and reduced cycle time. The goal was to install a comprehensive system, capable of monitoring and communicating between all processes, increasing efficiency and productivity.

The solution

Schneider Electric's Automation Business provided the PLCs, programming software, and training required to develop a system that could be validated to FDA standards. Approximately 150 Modicon PLCs are installed at the facility, working in conjunction with other control devices via Modbus Plus communications. The PLCs collect information from numerous sources and maintain the batch record for all processes, from raw material to finished product. Schneider Canada played a key role in helping Glaxo Smith-Kline achieve the levels of consistency and conformity required by the strict validation audits of the FDA.

There are 52 manufacturing cells, each containing at least two PLCs from Schneider Electric. Packaging cells are also equipped with PLCs, as is an automated bin washer.

Schneider Electric's Telemecanique sensors are installed on automated doors, conveyors and other machinery to sense bin and pallet position, and then send a signal to the PLC to initiate the next stage. Most of the automated controls were provided by Schneider Canada, including inductivity devices, proximity sensors, photoelectric controls, motor starters and emergency stops. Movement of material through the building's six floors and 52 cells is handled by a completely automated material handling system, which includes numerous conveyors, two AS/RS cranes, through-floor feeders and receivers.

Transparent Factory

Pharmaceutical manufacturer meets tough FDA standards with Schneider Electric solution

Schneider has things under control

The doors linking the production and packaging suites with the AS/RS are fully automated, opening only for the loads passing through. The crane software signals a door to open and sensors confirm the action. There are either one or two pickup-and-delivery stands per door, and the original relay logic for door control has been replaced by Schneider Electric PLCs.

Communication is facilitated via five Modbus Plus networks which gather data from 2700 input/output points. The interface supplied by Schneider allows delivery of data to Glaxo Smith-Kline's MIS Ethernet network. Because packaging and production occur under strict environmental conditions, building management systems are subject to close control. The Schneider Electric solution also included PLCs to control the low voltage power distribution throughout the building.

Customer benefits

Schneider Canada cooperated closely in the design of the logic control network, providing assistance in the Modbus Plus technical design, and proving very responsive to service needs, including emergency repairs and technical expertise. The end result was the installation of a PLC-based manufacturing system with an easily validated, state-of-the-art networking capability.

Software for the new installation offers the flexibility to upgrade from small to large PLCs, and to connect them to the same Modbus Plus network.

The open architecture and common processing language used for all Schneider Electric PLCs is an added benefit, especially for the international OEMs with whom Glaxo Smith-Kline regularly does business.



Telecommunication - Large telephone company



The existing installation

This massive telephone network is comprised of 1,340 phone switch buildings called Central Offices or "C.O.s." The C.O.s are distributed over a six-state area. The telephone system is powered by a 48 VDC battery located at the Central Office the connection point for all phones from the surrounding community. If local utility power fails, the battery continues to power the system for several minutes, until a genset or generating unit that supplies off-grid electricity starts automatically to maintain AC power feed to the charge system. The remote capability is provided by a dial-up 1200 baud modem link to the battery charging control system. Although it provides formatted ASCII text reports of battery system status, alarms, and operating statistics, the 1980's technology interface is slow and incapable of presenting large amounts of near real-time current and voltage information. The data it provides is limited to the DC part of the battery system. There are no capabilities for monitoring the genset, for running its required monthly test, or for monitoring/controlling of the AC power circuit breakers in the main switchboard.

Transparent Factory

PLC-based monitoring provides peak power to phone systems

The objective

- Provide more detailed, real-time and historical data to power engineers for maintaining and designing upgrades to the DC system.
- Track AC power, voltage, current and harmonic content.
- Deliver a complete overview of alarm status and power trends of all central offices in a multi-state operating region for central control room operators, engineers and managers.
- Provide manual load shedding capabilities to reduce utility power costs.
- Reduce engineering costs via remote testing of the genset.
- Provide on-line coordination with purchasing and equipment databases to simplify tracking and scheduling the purchase and installation of DC power components.
- Offer easy expansion options that include monitoring for other central office components (security, HVAC, etc.).

The solution

The Schneider Automation Industrial Applications Group (IAT) was chosen to design the new monitoring/control system. The PC system monitors all aspects of the power supply for the phone switch network utilizing the following equipment and instrumentation :

- Quantum PLC with Remote input/output and Momentum input/output modules.
- Power meters for monitoring and analyzing the utility and emergency AC bus.
- Current transformers for monitoring the AC branch circuits.
- Current transducers for monitoring AC and DC branch circuits.
- Voltage transducers for monitoring AC and DC branch circuits.
- Temperature probes for environmental and engine temperature monitoring.
- Pressure transducers for engine pressure monitoring.
- Serial ASCII interface for communicating with existing rectifier controller.
- Ethernet module for network access.
- Assorted discrete input/output for monitor and control.

The solution has three major components in each central office :

- The AC panel monitors circuit breaker status in the main switch board and AC and emergency bus power using circuit monitors to measure power and 31 harmonic values for all three phases of current and voltage. It also provides supervisory control for the circuit breakers.
- The DC panel reads battery string voltages and currents directly, and collects historical and current data from the battery controller, which is a microprocessor system manufactured by Bell Labs.
- The genset panel monitors the status of the generator starter battery, operating parameters, such as cooling water and exhaust temperatures, oil pressure, fuel level and status points from the genset controller. It also provides supervisory control for running the generator.

The solution (continued)

All controls are manually entered from the HMI. The new system interfaces with the hard-wired control circuits from the current system. For example, the genset is started by interrupting the Utility Voltage Present signal and activating automatic failover relay logic. All control circuits connected to the PLC are wired through a local override switch. If a local user overrides the PLC controls, all controls revert to the original phone company configuration.

Communications occur via an Ethernet card in the PLC to a router connected to the phone company frame relay network allocated for monitoring the systems. The control application was developed using FactoryLink software and an add-on package to manage log-on security and user access, which is set by the system administrator in the log-on database. The HMI is any PC connected to the phone company's dedicated power monitoring system frame relay network and running the FactoryLink WebClient software. The displays are downloaded from the server(s) running the phone company application. After a graphic display is downloaded, only dynamic data is passed over the network to keep the display up to date.

The application includes links to Excel spreadsheets and ACCESS databases. Data obtained from the PLCs can be saved to Excel spreadsheets for off-line analysis. In future applications, ACCESS data will be used to update certain operating parameters and/or alarms.

A power modeling tool enables the power engineer to evaluate the adequacy of existing battery strings to support current peak load and to analyze the operation with different numbers of batteries.

Customer benefits

- More varied and complete information - Power engineers can better analyze the operation of their assigned central offices.
- Comprehensive, graphic representation of the health of all central offices being monitored with easy access to any particular office, resulting in more efficient operation and more timely maintenance.
- Expansion possibilities to include the addition of servers supporting FactoryLink software.

Network Certification Services



Why Network certification services ?

Network Certification Services provide Microsoft/Cisco Certified Design Engineers to customers seeking optimized performance design for mission-critical industrial networks.

Benefits of Network certification services

Feature	Benefit
<ul style="list-style-type: none"> ■ Industrial Ethernet network designs are performed by Microsoft/Cisco Certified Design Engineers with years of Ethernet experience. These engineers are also trained in automation products and industrial control over Ethernet. 	<ul style="list-style-type: none"> ■ Optical network performance through certified designs using correct application of the latest network technology and automation equipment.
<ul style="list-style-type: none"> ■ Available Lab Services allow customers to conduct critical performance testing. 	<ul style="list-style-type: none"> ■ Optimizes and establishes the customers network performance before installation of the system.
<ul style="list-style-type: none"> ■ Online certification of Ethernet Networks 	<ul style="list-style-type: none"> ■ Customer receives verification that network is properly installed and the system will achieve maximum throughput.

Network Certification Services (continued)

Network certification services has four main service offerings that are billable on a time and materials basis :

- 1 Ethernet Network Design.
- 2 On-site troubleshooting and data throughput enhancement.
- 3 Field certification of installed networks.
- 4 Network laboratory use.

Questions and answers

Q. Why is there a group in Schneider Electric Automation handling Ethernet network designs ?

A. Customers have been requesting network design assistance, or help with trouble shooting existing problem networks.

Q. Why do customers use Schneider Network Certification Services rather than a local System Integrator ?

A. We would suggest the customer use both the local Systems integrator and Network Certification Services. The local Systems integrator can hire Network Certification Services as a subcontractor and get the Ethernet design expertise for their customers' needs. Customers benefit from using our Schneider Network Certification Services because of our in-depth knowledge of both our automation products and Ethernet networks. Our Certified Engineers are experts in both Schneider Automation Products and industrial Ethernet network designs.

Q. What is typically the most important aspect of designing industrial control Ethernet networks ?

A. High performance indicated through maximum data throughput, and fastest deterministic response times.

Q. How do I get more information ?

A. Either go to the support website at <http://eclipse.modicon.com> and click on the Ethernet Network Design link or contact Schneider Automation Technical support at 888-266-8705 or +1 978-794-0800 and ask for Network Certification Services.

Ordering procedure

Contact Schneider Automation Technical Support at : 888-266-8705 or +1 978-794-0800 and ask for Network Certification Services.

Network Certification Services works directly with customers and the Schneider country sales force to create a quote. The customer must place the order for network certification services through Schneider country sales organization.



Schneider Alliances

The **Schneider Alliances Partnership Program** is both an industrial and commercial program between Schneider Electric and its partners. It provides hardware and software automation products, system integration and services complementary to the offering of Schneider Electric's Industrial Automation Business.

Thanks to **Schneider Alliances**, customers are able to choose among the best in class products with an assurance of seamless integration within Schneider architectures. Partners also have access to a network of system integrators that specialize in a wide variety of industries and applications to fit the requirements of a broad base of customer requirements.

The **Schneider Alliances** partners network is a win-win association, that brings to everyone, product vendor or system integrator, a distinct competitive advantage.

The Transparent Factory Partners Program within Schneider Alliances has enjoyed tremendous growth. Capitalizing on Schneider Electric's pioneering role in bringing Internet and Ethernet technologies to the factory floor, the Transparent Factory Partnership Program offers members the opportunity to develop products complementary with leading technologies including the Modbus TCP/IP standard. This program also offers members access to MODBUS.ORG, 'the Community for Modbus users created by Modbus users'.

To learn more about Schneider Alliances and its Transparent Factory Partnership Program, please visit us at : <http://www.Modicon.com>

Transparent Factory

Community regulations and protective treatment

Community regulations

European Directives

The opening of European markets implies a harmonization of regulations in the various European Union member states.

European Directives are documents used to remove obstacles to the free movement of goods and their application is compulsory in all states of the European Union.

Member states are obliged to transcribe each Directive into their national legislation and, at the same time, to withdraw any conflicting regulations.

The Directives, particularly those of a technical nature with which we are concerned, only set objectives, called "general requirements".

The manufacturer must take all necessary measures to ensure that his products conform to the requirements of each Directive relating to his equipment.

As a general rule, the manufacturer affirms that his product conforms to the necessary requirements of the Directive(s) by applying the **CE** label to his product. **CE** marking is applied to Telemecanique products where relevant.

The significance of CE marking

■ **CE** marking on a product means that the manufacturer certifies that his product conforms to the relevant European Directives ; it is necessary in order that a product which is subject to a Directive(s) can be marketed and freely moved within the European Union.

■ **CE** marking is intended solely for the national authorities responsible for market regulation.

For electrical equipment, only conformity of the product to standards indicates that it is suitable for use, and only a guarantee by a recognised manufacturer can ensure a high level of quality.

One or more Directives, as appropriate, may apply to our products, in particular :

■ The Low Voltage Directive 72/23/EEC amended by Directive 93/68/EEC : **CE** marking under the terms of this Directive could not be applied before 1 January 1995 and is compulsory as of 1 January 1997.

■ The Electromagnetic Compatibility Directive 89/336/EEC, amended by Directives 92/31/EEC and 93/68/EEC : **CE** marking on the products covered by this Directive has been compulsory since 1 January 1996.

Protective treatment of equipment

Premium and Quantum PLCs meet the requirements of "TC" treatment (1).

For installations in industrial production workshops or in an environment which corresponds to "TH" treatment (2), Premium PLCs should be enclosed in casings with a minimum of IP 54 protection as prescribed by standards IEC 664 and NF C 20 040.

Premium and Quantum PLCs are supplied with an IP 20 protection index. They can therefore be installed without enclosure in locations with restricted access which do not exceed pollution degree 2 (control room which does not contain a machine or dust-producing activity).

(1) "TC" treatment : all climate treatment.

(2) "TH" treatment : treatment for hot and humid environments.

© Copyright Schneider Automation 2002.

All rights reserved. No part of this work may be translated and/or reproduced or copied in any form or by any means - graphic, electronic or mechanical including photocopying, recording, taping or storage in an information retrieval system.

All software quoted in this document is the property of Schneider Automation, or a third party which has granted rights to Schneider Automation. The supply of such software confers a non-exclusive licence on the recipient to use such software solely for the purpose for which it was supplied.

Any copying of such software, etc. (except solely for the purpose of producing back-up and security copies) is totally forbidden.

All products, hardware, software and services shown in this document are subject to modification and change without notice. Any descriptions or specifications given herein shall not be capable as being interpreted as part of or a condition of any contract relative to such product, software or service.

Concept, Lexium, PL7 are registered trademarks of Schneider Automation.

Modicon, NUM, Telefast, Telemecanique, XBT are registered trademarks of Schneider Electric.

All other products and brands quoted in this document are registered trademarks of their respective holders.

Transparent Factory

Automation Product Certifications









Product certifications and marine classification authorities

In some countries, certification of certain electrical components is enforced by law. A standard conformity certificate is then issued by the official organization. Each certified product must carry approval symbols when enforced.

Use on board merchant navy vessels generally requires prior approval (= certification) of an electrical device by certain marine classification authorities.

Key	Certification body	Country
CSA	Canadian Standards Association	Canada
C-Tick	Australian Communication Authority	Australia
UL	Underwriters Laboratories	USA
Key	Classification authority	Country
ABS	American Bureau of Shipping	USA
BV	Bureau Veritas	France
DNV	Det Norske Veritas	Norway
GL	Germanischer Lloyd	Germany
GOST	Institut de recherche Scientifique Gost Standardt	C.I.S.
LR	Lloyd's Register	United-Kingdom
RINA	Registro Italiano Navale	Italy
RRS	Register of Shipping	C.I.S.

The table below shows the situation as of the 01.05.2002 for certifications obtained or pending from organizations for base PLCs. Further information regarding certified modules can be obtained from your Regional Sales Office.









	Certifications				Others		
	 CSA Canada	 ACA Australia	 SIMPARS Australia	 UL USA	 Class 1 Div 2 Hazardous locations Etats-Unis	 BG Germany	 AS-i Europe
Normal execution							
							
							
ABE-7				E164866			
CCX 17				E95257			
Lexium MHD/BPH							
Magelis IPC				E95257			
Magelis TXBT-F	LR 44087-77	N998					
Magelis XBT-F/FC	LR 44087-77	N998					
Magelis XBT-H/P/E/HM/PM	LR 44087-77			E95257			
Micro	LR 58905-30	N998	NI97/0039 Ex2314X	E95257	LR 58905-30	(1)	(2)
Momentum		N998					
Nano	LR 58905-42	N998		E95257			
Premium	LR 58905-32S	N998	NI97/0039 Ex2314X	E95257	LR 58905-32S	(3)	(4)
Quantum							
TBX	LR 58905-21 LR 58905-21 (S)	N998		E95257			
TSX/PMX 47 to 107	LR 58905-00			E95257			(5)

- (1) TSX DPZ 10D2A safety module
 (2) TSX SAZ 10 AS-i bus master module and TSX SUP A02/A05 AS-i bus power supplies
 (3) TSX PAY 262/282 safety modules
 (4) TSX SAY 100 AS-i bus master modules
 (5) TBX SAP 10 Fipio/AS-i gateway

Transparent Factory

Automation Product Certifications

Product certifications and marine classification authorities (continued)

	Sociétés de classification des navires							
	 ABS ABS USA	 BV BV France	 DNV DNV Norway	 GL GL Germany	 GOST GOST CEI	 LR LR United-Kingdom	 RINA RINA Italy	 RRS RRS CIS
ABE-7				99155-96HH				
CCX 17								
Lexium MHD/BPH								
Magelis IPC								
Magelis TXBT-F								
Magelis XBT-F/FC								
Magelis XBT-H/P/E/HM/PM								
Micro		45016846A001	A7961	99086-96HH		97/00114	ELE/48896/1	
Momentum								
Nano		45017055A001	A7773			Temporary MSL/99/0159		
Premium	00MS14569-X 00-LD186857- PDA	4501H07135/B0	A7957	99405-97HH		98/00088	ELE/35897/1	
Quantum								
TBX		45037058A001	A7952	99405-97HH			ELE/43795/2	
TSX/PMX 47 to 107		45015106D001	A7952	94511HH			ELE/43795/3 (TSX P107)	96089250 (TSX 47)

Conformity to European Directives: CE marking

All products are conformed to CE marking. See Community regulations page 101.



Schneider Electric worldwide

Up-dated: 22-03-2002

Algeria	■ Schneider Electric	15 chemin Poirson 16030 El-Biar Alger	Tel. : +213 21 92 97 02 à 09 Fax : +213 21 92 97 00 à 01	
Argentina	■ Schneider Argentina	Viamonte 2850 - 1678 Caseros (provincia Buenos Aires)	Tel.: +54 1 716 88 88 Fax: +54 1 716 88 77	www.schneider-electric.com.ar
Australia	■ Schneider Electric (Australia) Pty. Limited	2 Solent Circuit Norwest Business Park Baulkham Hill _ NSW 2153	Tel.: +61 298 51 28 00 Fax: +61 296 29 83 40	www.schneider.com.au
Austria	■ Schneider Austria Ges.m.b.H.	Birostrasse 11 1239 Wien	Tel.: +431 610 540 Fax: +431 610 54 54	www.schneider-electric.at
Bahrain	■ Schneider Electric	Floor 1 - Juma Building Abu Horaira Avenue PO Box 355 - 304 Manama	Tel.: +97 322 7897 Fax: +97 321 8313	
Belarus	■ Schneider Electric Industries SA	Prospect Macherova 5, of. 202 220004 Minsk	Tel. : +375 172 23 75 50 Fax : +375 172 23 97 61	
Belgium	■ Schneider Electric nv/sa	Dieweg 3 B - 1180 Brussels	Tel.: +3223737711 Fax: +3223753858	www.schneider-electric.be
Brazil	■ Schneider Electric Brasil Ltda.	Avenida Das Nações Unidas 23223 Jurubatuba - CEP 04795-907 São Paulo-SP	Tel.: +55 55 24 52 33 Fax: +55 55 22 51 34	www.schneider-electric.com.br
Bulgaria	■ Schneider Electric	Expo 2000, Boulevard Vaptzarov 1407 Sofiav	Tel.: +3592 919 42 Fax: +3592 962 44 39	www.schneiderelectric.bg
Cameroon	■ Schneider Electric Cameroun	16, rue de l'Hôtel de Ville BP12087 - Douala	Tel.: +237 42 69 30 Fax: +237 43 11 94	
Canada	■ Schneider Canada	19, Waterman Avenue M4 B1Y2 Toronto - Ontario	Tel.: +1 416 752 8020 Fax: +1 416 752 4203	www.schneider-electric.ca
Chile	■ Schneider Electric Chile S.A.	Avda. Pde Ed. Frei Montalva, 6001-31 Conchali - Santiago	Tel.: +56 2 444 3000 Fax: +56 2 423 9335	www.schneider-electric.co.cl
China	■ Schneider Beijing	Landmark bldg-Room 1801 8 North Dong Sanhuan Rd Chaoyang District 100004 Beijing	Tel.: +86 10 65 90 69 07 Fax: +86 10 65 90 00 13	www.schneider-electric.com.cn
Colombia	■ Schneider Electric de Colombia S.A.	Calle 45A #102-48 Bogota DC	Tel.: +57 1 426 97 00 Fax: +57 1 426 97 40	
Costa Rica	■ Schneider Centroamérica Ltda.	1.5 kmts oeste de la Embajada Americana, Pavas, San José, Costa Rica C.A. Apartado: 4123-1000 San Jose	Tel.: +506 232-60-55 Fax: +506 232-04-26	www.schneider-ca.com
Côte d'Ivoire	■ Schneider Electric Afrique de l'Ouest et Centrale	Rue Pierre et Marie Curie 18 BP 2027 Abidjan 18	Tel.: +225 21 75 00 10 Fax: +225 21 75 00 30	
Croatia	■ Schneider Electric SA	Fallerovo Setaliste 22 HR - 10000 Zagreb	Tel.: +385 1 367 100 Fax: +385 1 367 111	
Cuba	■ Schneider Electric	Bureau de Liaison de La Havane Calle 36- N°306-Apto1 Entre 3ra y 5ta Avenida Miramar Playa Habana	Tel.: +53 724 15 59 Fax: +53 724 12 17	
Czech Republic	■ Schneider Electric CZ, s.r.o.	Thámová 13 Praha 8 - 186 00	Tel.: +420 2 810 88 111 Fax: +420 2 24 81 08 49	www.schneider-electric.cz
Denmark	■ Schneider Electric A/S	Baltorpbakken 14 DK-2750 Ballerup	Tel.: +45 44 73 78 88 Fax: +45 44 68 5255	www.schneider-electric.dk
Dominican Republic	■ Schneider Electric	Calle Jacinto Manon Esq. Federico Geraldino Edificio D' Roca Plaza Suite 402, Ens. Paraiso - Santo Domingo	Tel.: +1 809 334 66 63 Fax: +1 809 334 66 68	
Ecuador	■ Schneider Ecuador	Av. de los Shyris y Rio Coca Esq. Edificio Eurocentro Segundo Piso 6466 Quito	Tel.: +593 2 25 03 23 Fax: +593 2 43 49 40	
Egypt	■ Schneider Electric Egypt	68, El Tayaran Street Nasr City, 11371 - Cairo	Tel.: +20 24 01 01 19 Fax: +20 24 01 66 87	www.schneider.com.eg
Estonia	■ Lexel Electric	Ehitajate tee 110 EE 12618 Tallinn	Tel. : +372 650 97 00 Fax : +372 650 97 22	
Finland	■ Schneider Electric Oy	Sinikalliontie 16 02630 Espoo	Tel. : +358 9 5270 0359 Fax : +358 9 5270 0376	www.schneider-electric.fi
France	■ Schneider Electric SA	5, rue Nadar 92500 Rueil Malmaison	Tel.: +33 (0)1 41 29 82 00 Fax: +33 (0)1 47 51 80 20	www.schneider-electric.fr
Germany	■ Schneider Electric GmbH	Gothaer Straße 29 D-40880 Ratingen	Tel.: +49210 240 40 Fax: +492 10 240 49 256	www.schneider-electric.de
Ghana	■ Schneider Electric	Private Mail Bag - Kotoa Airport Accra	Tel. : +23321 70 10 842/11 687 Fax : +233 21 77 96 22	
Greece	■ Schneider Electric AE	14th km - RN Athens-Lamia GR - 14564 Kifissia	Tel.: +3016 29 52 00 Fax: +3016 29 52 10	www.schneider-electric.com.gr



Schneider Electric worldwide

Up-dated: 22-03-2002

Haiti	■ Schneider Electric	Calle Jacinto Manon Esq. Federico Geraldino Edificio D' Roca Plaza Suite 402, Ens. Paraiso - Santo Domingo	Tel.: +809 334 66 63 Fax: +809 334 66 68	
Hong Kong	■ Schneider Electric (Hong Kong) Ltd	Room 3108-28, 31th Floor, Sun Hung Kai Centre, 30 Harbour Road, Wanchai	Tel.: +852 25 65 06 21 Fax: +852 28 11 10 29	
Hungary	■ Schneider Electric Hungária Villamossági Rt.	Fehérvári út 108 – 112 H-1116 Budapest	Tel.: +36 1 382 26-06 Fax: +36 1 206 1429	www.schneider-electric.hu
India	■ Schneider Electric India	Max House, 1 Dr Jha Marg, Okhla 110 020 New Dehli	Tel.: +91 11 631 85 84 Tel.: +91 11 631 71 61	www.schneiderelectric-in.com
Indonesia	■ P.T. Schneider Indonesia	Ventura Building 7th Floor Jalan R.A. Kartini Kav.26 Cilandak 12430 Jakarta	Tel.: +62 +21 750 44 06 Fax: +62 +21 750 44 15/ 16	www.schneider-electric.co.id
Iran (Islamic Republic of)	■ Telemecanique Iran	1047 Avenue VALI ASSR P.O. Box 15875-3547 15116 Teheran	Tel.: +98 218 71 01 42 Fax: +98 218 71 81 87	
Irak	■ Schneider Electric Industries SA	38050 Grenoble Cedex 9	Tel.: +33 04 76 60 54 27 Fax: +33 04 76 60 56 60	
Ireland	■ Schneider Electric Ireland	Maynooth Road Cellbridge - Co. Kildare	Tel.: +353+0 1 6012200 Fax: +353+0 1 6012201	www.schneiderelectric.ie
Italy	■ Schneider Electric S.p.A.	Centro Direzionale Colleoni Palazzo Sirio - Viale Colleoni, 7 20041 Agrate Brianza (Mi)	Tel.: +39 39 655 8111 Fax: +39 39 605 6237	www.schneiderelectric.it
Japan	■ Schneider Electric Japan Ltd	SK Bldg, Sendagaya 4-14-4, Sendagaya Shibuya-Ku - 151 Tokyo	Tel.: +81 354 74 44 74 Fax: +81 354 74 44 70	www.schneider-electric.co.jp
Kazakhstan	■ Schneider Electric Kazakhstan Liaison Office	Prospekt Abaia 157 off 9 480009 Almaty	Tel.: +7 327 250 93 88 Tel.: +7 327 250 63 70	
Kenya	■ Schneider East Africa	Power Technics Complex PO Box 46345 - Nairobi	Tel.: +254 2.824.156 Fax: +254 2.824.157	
Kuwait	■ Schneider Electric Kuwait	Al Gaas Tower - Sharq 2nd Floor PO Box 20092 - 13 061 Safat	Tel.: +965 240 75 46 Fax: +965 240 75 06	
Latvia	■ Lexel Electric	60A A.Deglava str. LV1035 Riga	Tel.: +371 780 23 74/75 Fax: +371 754 62 80	
Lebanon	■ Schneider Electric Lebanon	Ashadia Bldg, 8th Floor Tabaris, Ashrafieh, P.O. Box 166223 Beyrouth	Tel.: +961 1 20 46 20 Tel.: +961 1 20 31 19	
Lithuania	■ Lexel Electric	44, Verkiu str. LT-2012 Vilnius	Tel.: +370 278 59 59/61 Fax: +370 278 59 60	
Malaysia	■ Schneider Electric (Malaysia) Sdn Bhd	No.11 Jalan U1/19, Seksyen U1 Hicom-Glenmarie Industrial Park Shah Alam 40150 Selangor Darul Ehsan	Tel.: +60 37 05 11 50 Fax: +60 37 05 11 70	www.schneider-electric.com.my
Martinique	■ Schneider Electric	Schneider Electric Immeuble Cottrell ZI de la Lézarde 97232 Le Lamentin	Tel.: +05 96 51 06 00 Fax: +05 96 51 11 26	
Mexico	■ Groupe Schneider Mexico	Calz. Rojo Gomez N° 1121 Col. Guadalupe del Moral México 09300	Tel.: +525 686 30 00 Fax: +525 686 24 09	www.schneider-electric.com.mx
Morocco	■ Schneider Electric Maroc	26, rue Ibnou Khalikane Quartier Palmiers 20100 Casablanca	Tel.: +212 299 08 48 to 57 Fax: +212 299 08 67 and 69	www.schneider.co.ma
Netherlands	■ Schneider Electric BV	Waarderweg 40 - Postbus 836 2003 RV Haarlem	Tel.: +31 23 512 4124 Fax: +31 23 512 4100	www.schneider-electric.nl
New Zealand	■ Schneider Electric (NZ) Ltd	14 Charann Place Avondale P.O. Box 15355 - New Lynn Auckland	Tel.: +64 +9 820 1820 Fax: +64 +9 820 1821	
Nigeria	■ Merlin Gerin Nigeria Ltd	Plot 25 Sanni Tola Sonolki Close Off Harold Sodipo Crescent PO Box 12 505 - Ikeja - Lagos	Tel.: +234 14 93 63 99 Fax: +234 14 97 45 99	
Norway	■ Schneider Electric Norge A/S	Solgaard Skog 2 Postboks 128 - 1501 Moss	Tel.: +47 6924 9700 Fax: +47 6925 7871	www.schneider-electric.no
Oman	■ Schneider Electric CA	c/o Arab Development Co PO Box 439 - 113 Muscat	Tel.: +968 77 163 64 Fax: +968 77 104 49	
Pakistan	■ Schneider Electric Pakistan	302 Clifton Center Clifton Block J - Karachi 75500	Tel.: +92 21 586 3561 to 63 Fax: +92 21 586 3564	
Peru	■ Schneider Electric Peru S.A.	Los Telares n°231 Urb. Vulcano, Ate Lima 03	Tel.: +511 348 44 11 Fax: +511 348 05 23	www.schneider-electric.com.pe
Philippines	■ Schneider Electric Philippines, Inc	Schneider Electric Philippines, Inc 1314 Batangas Street Makati City 1234 - Metro-Manila	Tel.: +63 28 44 84 18 Fax: +63 28 16 00 63	



Schneider Electric worldwide

Up-dated: 22-03-2002

Poland	■ Schneider Electric Polska Sp.zo.o.	ul. Domaniewska 41 02-672 - Warszawa	Tel.: +48 22 606 25 00 Fax: +48 22 606 11 66 Fax: +48 22 606 11 58	www.schneider-electric.pl
Portugal	■ Schneider Electric Portugal	Av.do Forte, 3 Edifício Suécia II, Piso 3-A CP 2028 Carnaxide 2795 Linda-A-Velha	Tel.: +351 21 416 5800 Fax: +351 21 416 5857	www.schneiderelectric.pt
Qatar	■ Schneider Electric Qatar Branch	c/o Khalifa BinFahred Al Thani Trad.and Co - P.O. Box 4484 Doha	Tel.: +97 4424358 Fax: +97 4424358	
Reunion	■ Schneider Electric	Immeuble Futura, 190, rue des 2 canons BP 646 - 97497 Sainte Clothilde	Tel.: +262 28 14 28 Fax: +262 28 39 37	
Romania	■ Schneider Electric	Bd Ficusului n°42 Apimondia, Corp.A, et.1, Sector 1 Bucuresti	Tel.: +401 203 06 50 Fax: +401 232 15 98	www.schneider-electric.ro
Russian Federation	■ Schneider Electric ZAO	Enisseyskaya 37 129 281 Moscow	Tel.: +7095 797 40 00 Fax: +7095 797 40 03	www.schneider-electric.ru
Saudi Arabia	■ Schneider Electric	Second Industrial City P.O. Box 89249 - 11682 Riyadh	Tel.: +966 1 265 1515 Fax: +966 1 265 1860	
Senegal	■ Schneider Electric Sénégal	BP 15952 - Dakar-Fann Rond point N'Gor - Dakar	Tel.: +221 820 68 05 Fax: +221 820 58 50	
Singapore	■ Schneider Electric Singapore Pte Ltd	10 Ang Mo Kio Street 65 #02-17/20 TechPoint Singapore 569059	Tel.: +65 484 78 77 Fax: +65 484 78 00	www.schneider-electric.com.sg
Slovak Republic	■ Schneider Electric Slovakia spol s.r.o.	Borekova 10 SK-821 06 Bratislava	Tel.: +4217 552 40 10/20 Fax: +4217 552 40 00	www.schneider-electric.sk
Slovenia	■ Schneider Electric, d.o.o.	Dunasjka 47 1000 Ljubljana	Tel. : +386 1 23 63 555 Fax : +386 1 23 63 559	www.schneider-electric.si
South Africa	■ Schneider Electric South Africa (PTY) Ltd	Cnr Bekker & Montrose roads 1685 - Midrand.	Tel.: +27 11 254 6400 Fax: +27 11 315 8830	www.schneider-electric.co.za
South Korea	■ Schneider Electric Korea	3Floor, Cheil Bldg., 94-46, 7-Ka Youngdeungpodong, Youngdeungpo-ku 150-037 Seoul	Tel.: +82 2 2630 9700 Fax: +82 2 2630 9800	www.csinfo.co.kr/schneider/
Spain	■ Schneider Electric España, S.A.	Pl. Dr. Letamendi, 5-7 08007 Barcelona	Tel.: +34 93 484 3100 Fax: +34 93 484 3308	www.schneiderelectric.es
Sweden	■ Schneider Electric AB	Djupdalsvägen 17/19 19129 Sollentuna	Tel.: +46 8 623 84 00 Fax: +46 8 623 84 85	www.schneider-electric.se
Switzerland	■ Schneider Electric (Switzerland) S.A.	Schermerwaldstrasse 11 Postfach - CH - 3063 Ittigen	Tel.: +41 31 917 3333 Fax: +41 31 917 3355	www.schneider-electric.ch
Syrian Arab Republic	■ Schneider Electric Syria	Shakib Arslan Street - Abou Roumaneh PO Box 33876 - Damas	Tel.: +963 11 333 10 26 Fax: +963 11 331 08 67	
Taiwan, Republic of China	■ Schneider Electric Taiwan Co Ltd	11F-2, N°51, Keelung Road, Sec.2 110 Taipei	Tel.: +886 2 27 33 14 64 Fax: +886 2 27 33 64 10	www.schneider-electric.com.tw
Thailand	■ Schneider (Thailand) Ltd	20th Floor Richmond Building 75 Sukhumvit 26 Road, Klongtoey Bangkok 10110	Tel.: +66 2 324 6000 Fax: +66 2 204 9816	www.schneider-electric.co.th
Tunisia	■ Schneider Electric Tunisie	2045 Les Berges du lac Tunis	Tel.: +216 71 960 477 Fax: +216 71 960 342	
Turkey	■ Schneider Elektrik Sanayi Ve Ticaret A.S.	Tütüncü Mehmet Efendi Cad. N°:110 Kat 1-2 - 81080 Göztepe - Istanbul	Tel.: +90 21 63 86 95 70 Fax: +90 21 63 86 38 75	www.schneiderelectric.com.tr
Turkmenistan	■ Schneider Electric Turkmenistan Liaison Office	rue Neitralny Turkmenistan 28, off.326/327 74 000 Achgabad	Tel. : +993 12 46 29 52 Fax : +993 12 46 29 52	
Ukraine	■ Schneider Electric	Rue Krechtchalik 2 252601 Kiev	Tel.: +380 44 462 04 25 Fax: +380 44 462 04 24	
United Arab Emirates	■ Schneider Electric Abu Dhabi	PO Box 29580 Office Floor 2/Lulu Street Al Marina Plaza Tower Abu Dhabi	Tel.: +9712 6 339444 Fax: +9712 6 316606	
United Kingdom	■ Schneider Electric Ltd	Braywick House East Windsor Road - Maidenhead Berkshire SL6 1 DN	Tel.: +44 (0)1 628 508 500 Fax: +44 (0)1 628 508 508	www.schneider.co.uk
United States	■ Schneider Electric	North American Division 1415 Roselle Road Palatine - IL 60067	Tel.: +1 847 397 2600 Fax: +1 847 925 7500	www.squared.com
Uruguay	■ Schneider Electric Uruguay S.A.	Gabriela Pereira 3039 Montevideo	Tel.: +59 82 707 2392 Fax: +59 82 709 0713	
Venezuela	■ Schneider Mg SD TE, S.A	Calle 162/ Piso 2 Edificio Centro Cynamid La Urbina, 1070 - 75319 Caracas	Tel.: +58 2 241 13 44 Fax: +58 2 243 60 09	www.schneider-electric.com.ve



Schneider Electric worldwide

Up-dated: 22-03-2002

Viet Nam	■ R.R.O. of Schneider Electric S.A.	Unit 808, 8th Floor Me Linh Point Tower 2 Ngo Duc Ke Street, District 1 Ho Chi Minh City	Tel.: +84 8 829 60 72 Fax: +84 8 829 60 67
Yougoslavia	■ Schneider Electric Yugoslavia Rep. Office	Gracanicka 1 11000 Belgrade	Tel.: +381 11 328 19 47 Fax: +381 11 328 6 52
Zambia	■ Schneider Zambia	Zambia Office c/o Matipi Craft Center Building Plot 1036 - Accra Road PO Box 22792 - Kitwe	Tel.: +260 222 22 52 Fax: +260 222 83 89
Zimbabwe	■ Schneider Electric	Zimbabwe Liaison Office 75A Second Street (corner Livingstone Avenue) Harare	Tel.: +263 4 707 179/180 Fax: +263 4 707 176

For all the other countries, contacts are ensured by the Regional Divisions (see below).

Africa & Middle-East Zone

Arabic Peninsula Region	■ Schneider Electric	Second Industrial City P.O. Box 89249 11682 Riyadh Saudi Arabia	Tel.: +(966) 1 265 15 15 Fax: +(966) 1 265 18 60
Middle-East Region	■ Schneider Elektrik A.S.	Sanayi Ve Ticaret A.S. Tütüncü Mehmet Efendi Cad. N°:110 Kat. 1-2 81080 Götztepe-Istanbul Turkey	Tel.: +(90) 2163 86 95 70 Fax: +(90) 21 63 86 38 75 www.schneider-electric.com.tr
North-East Africa Region	■ Schneider Electric Egypt	68, El Tayaran Street Nasr City, 11371 Cairo Egypt	Tel.: +(20) 24 01 01 19 Fax: +(20) 24 01 66 87 www.schneider.com.eg
North-West Africa Region	■ Schneider Electric Maroc	26, rue Ibnou Khalikane Quartier Palmiers 20100 Casablanca Morocco	Tel.: +(212) 299 08 48 à 57 Fax: +(212) 299 08 67 et 69 www.schneider.co.ma
South Africa Region	■ Schneider Electric South Africa (PTY) Ltd	Cnr Bekker & Montrose roads 1685 - Midrand. South Africa	Tel.: +(27) 11 254 6400 Fax: +(27) 11 315 8830 www.schneider-electric.co.za
South Asia Region	■ Schneider Electric India Pvt Ltd.	D-27 South Extension Part II 110 049 New Dehli India	Tel.: +(91) 116 25 76 58 Fax: +(91) 116 25 80 80 www.schneiderelectric.in.com

Asian Zone

Great China	■ Schneider Beijing	Landmark bldg-Room 1801 8 North Dong Sanhuan Rd, Chaoyang District 100004 Beijing China	Tel.: +(86) 10 65 90 69 07 Fax: +(86) 10 65 90 00 13 www.schneider-electric.com.cn
South-East Asia	■ Schneider South East Asia (HQ) Pte Ltd.	460 Alexandra Road #15-01 PSA building 119963 Singapore	Tel.: +(65) 270 23 66 Fax: +(65) 273 46 10

European Zone

ECE-CIS Countries	■ Schneider Electric ZAO	Enisseyskaya 37 129 281 Moscow	Tel.: +7095 797 40 00 Fax: +7095 797 40 03 www.schneider-electric.ru
Nordic countries	■ Schneider Electric A/S	Baltorpbakken 14 DK - 2750 Ballerup Denmark	Tel.: +(45) 44 73 7888 Fax: +(45) 44 68 5255 www.schneider-electric.dk
East Adriatic countries	■ Schneider Electric SA	Fallerovo Setaliste 22 10000 Zagreb Croatia	Tel.: +(385) 1 3667 100 Fax: +(385) 1 3667 111 www.schneider-electric.hr

North-America Zone

	■ Schneider Electric North American Division	1415 Roselle Road Palatine IL 60067 USA	Tel.: +(1) 847 397 2600 Fax: +(1) 847 925 7500 www.squared.com
--	---	---	---

South America & Caribbean Zone

	■ Schneider Electric Emp. Partic. Head Office Zone	Avenida Brigadeiro Faria Lima 1478 15° A 01451-913 São Paulo-SP Brazil	Tel.: +(55) 11 816 45 00 Fax: +(55) 11 813 09 43 www.schneider.com.br
--	---	---	---

Pacific Zone

	■ Schneider Electric (Australia) Pty. Limited	2, Solent Circuit Norwest Business Park NSW 2153 Baulkham Hill Australia	Tel.: +(61) 298 51 28 00 Fax: +(61) 296 29 83 10 www.schneider.com.au
--	--	---	---