

POWERLOGIC® Circuit Monitor Series 3000 Reference Manual

Retain for future use

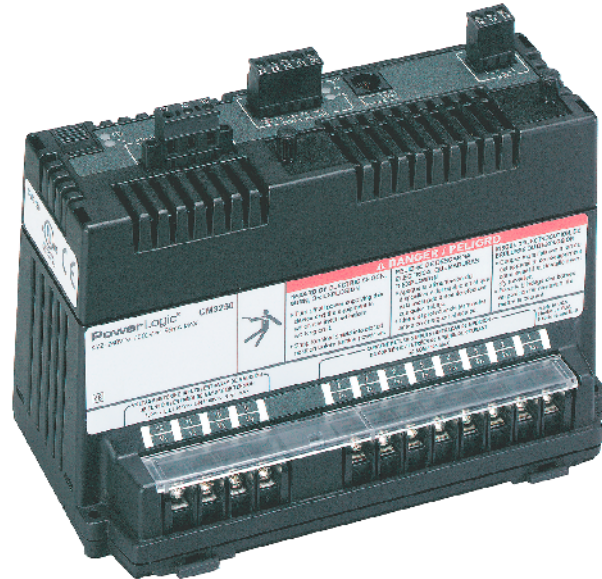

NOTICE

Read these instructions carefully and look at the equipment to become familiar with the device before trying to install, operate, service, or maintain it. The following special messages may appear throughout this bulletin or on the equipment to warn of potential hazards or to call attention to information that clarifies or simplifies a procedure.



The addition of either symbol to a “Danger” or “Warning” safety label indicates that an electrical hazard exists which will result in personal injury if the instructions are not followed.



This is the safety alert symbol. It is used to alert you to potential personal injury hazards. Obey all safety messages that follow this symbol to avoid possible injury or death.

DANGER

DANGER indicates an imminently hazardous situation which, if not avoided, **will result in** death or serious injury.

WARNING

WARNING indicates a potentially hazardous situation which, if not avoided, **can result in** death or serious injury.

CAUTION

CAUTION indicates a potentially hazardous situation which, if not avoided, **can result in** minor or moderate injury.

CAUTION

CAUTION, used without the safety alert symbol, indicates a potentially hazardous situation which, if not avoided, **can result in** property damage.

NOTE: Provides additional information to clarify or simplify a procedure.

PLEASE NOTE

Electrical equipment should be installed, operated, serviced, and maintained only by qualified personnel. This document is not intended as an instruction manual for untrained persons. No responsibility is assumed by Square D for any consequences arising out of the use of this manual.

Class A FCC Statement

This equipment has been tested and found to comply with the limits for a Class A digital device, pursuant to part 15 of the FCC Rules. These limits are designated to provide reasonable protection against harmful interference when the equipment is operated in a commercial environment. This equipment generates, uses, and can radiate radio frequency energy and, if not installed and used in accordance with the instruction manual, may cause harmful interference to radio communications. Operation of this equipment in a residential area is likely to cause harmful interference in which case the user will be required to correct the interference at his own expense.

CONTENTS

NOTICE 2

PLEASE NOTE 2

CLASS A FCC STATEMENT 2

CONTENTS 1

CHAPTER 1—INTRODUCTION 1

CHAPTER CONTENTS 1

WHAT IS THE CIRCUIT MONITOR? 2

 Accessories and Options for the Circuit Monitor 3

 Features 3

TOPICS NOT COVERED IN THIS BULLETIN 4

FIRMWARE 4

CHAPTER 2—SAFETY PRECAUTIONS 5

CHAPTER 3—OPERATION 7

CHAPTER CONTENTS 7

OPERATING THE DISPLAY 8

 How the Buttons Work 8

 Display Menu Conventions 9

 Selecting a Menu Option 9

 Changing a Value 9

MAIN MENU OVERVIEW 10

CONFIGURING THE CIRCUIT MONITOR USING THE SETUP MENU 11

 Setting Up the Display 11

 Setting Up the Communications 12

 Setting the Device Address 12

 RS-485 and Infrared Port Communications Setup 13

 Ethernet Communications Card (ECC) Setup 14

 Redirecting the Port 14

 Redirecting the IR Port to the ECC Subnet 14

 Redirecting the IR Port to RS-485 16

 Setting Up the Metering Functions of the Circuit Monitor 16

 Setting Up Alarms 19

 Creating a New Custom Alarm 20

 Setting Up and Editing Alarms 21

 Setting Up I/Os 24

 Configuring I/O Modules 24

 Setting Up Passwords 26

 Advanced Setup Features 27

 Creating Custom Quantities to be Displayed 27

 Creating Custom Screens 30

 Viewing Custom Screens 33

 Advanced Meter Setup 33

RESETTING MIN/MAX, DEMAND, AND ENERGY VALUES 36

VIEWING METERED DATA 37

 Viewing Metered Data from the Meters Menu 37

Viewing Minimum and Maximum Values from the Min/Max Menu . . .	38
VIEWING ALARMS	40
Viewing Active Alarms	41
View and Acknowledging High Priority Alarms	41
VIEWING I/O STATUS	42
READING AND WRITING REGISTERS	43
PERFORMING A WIRING ERROR TEST	44
Running the Diagnostics Wiring Error Test	45
CHAPTER 4—METERING CAPABILITIES	49
CHAPTER CONTENTS	49
REAL-TIME READINGS	50
MIN/MAX VALUES FOR REAL-TIME READINGS	50
Power Factor Min/Max Conventions	51
VAR SIGN CONVENTIONS	53
DEMAND READINGS	54
Demand Power Calculation Methods	55
Block Interval Demand	55
Synchronized Demand	57
Demand Current	57
Demand Voltage	57
Thermal Demand	58
Predicted Demand	58
Peak Demand	59
Generic Demand	59
Input Pulse Demand Metering	60
ENERGY READINGS	61
POWER ANALYSIS VALUES	64
CHAPTER 5—INPUT/OUTPUT CAPABILITIES	67
CHAPTER CONTENTS	67
I/O OPTIONS	68
DIGITAL INPUTS	69
DEMAND SYNCH PULSE INPUT	70
RELAY OUTPUT OPERATING MODES	71
MECHANICAL RELAY OUTPUTS	73
Setpoint-controlled Relay Functions	74
SOLID-STATE KYZ PULSE OUTPUT	74
2-Wire Pulse Initiator	75
3-Wire Pulse Initiator	75
CALCULATING THE KILOWATTHOUR-PER-PULSE VALUE	76
CHAPTER 6—ALARMS	77
CHAPTER CONTENTS	77

ABOUT ALARMS	78
Alarms Groups	78
Setpoint-Driven Alarms	79
Priorities	81
Alarm Levels	81
CUSTOM ALARMS	82
SETPOINT-CONTROLLED RELAY FUNCTIONS	82
Types of Setpoint-Controlled Relay Functions	83
SCALE FACTORS	85
SCALING ALARM SETPOINTS	86
ALARM CONDITIONS AND ALARM NUMBERS	87
CHAPTER 7—LOGGING	93
CHAPTER CONTENTS	93
ALARM LOG	94
Alarm Log Storage	94
DATA LOGS	94
Alarm-Driven Data Log Entries	95
Organizing Data Log Files	95
Data Log Storage	95
MIN/MAX LOGS	96
Min/Max Log	96
Interval Min/Max/Average Log	96
Interval Min/Max/Average Log Storage	97
MAINTENANCE LOG	97
MEMORY ALLOCATION	98
CHAPTER 8—WAVEFORM AND EVENT CAPTURE	101
CHAPTER CONTENTS	101
TYPES OF WAVEFORM CAPTURES	102
Steady-state Waveform Capture	102
Initiating a Steady-state Waveform	102
Disturbance Waveform Capture	102
100MS RMS EVENT RECORDING (CM3350 ONLY)	103
SETTING UP THE CIRCUIT MONITOR FOR AUTOMATIC EVENT CAPTURE	104
Setting Up Alarm-Triggered Event Capture	104
Setting Up Input-Triggered Event Capture	104
WAVEFORM STORAGE	104
HOW THE CIRCUIT MONITOR CAPTURES AN EVENT	105
CHAPTER 9—DISTURBANCE MONITORING (CM3350)	107
CHAPTER CONTENTS	107
ABOUT DISTURBANCE MONITORING	108
CAPABILITIES OF THE CIRCUIT MONITOR DURING AN EVENT ...	111

USING THE CIRCUIT MONITOR WITH SMS TO PERFORM DISTURBANCE MONITORING	112
UNDERSTANDING THE ALARM LOG	112
CHAPTER 10—MAINTENANCE AND TROUBLESHOOTING	115
CHAPTER CONTENTS	115
CIRCUIT MONITOR MEMORY	117
IDENTIFYING THE FIRMWARE VERSION	118
VIEWING THE DISPLAY IN DIFFERENT LANGUAGES	118
GETTING TECHNICAL SUPPORT	118
TROUBLESHOOTING	119
APPENDIX A—ABBREVIATED REGISTER LISTING	121
CONTENTS	121
ABOUT REGISTERS	121
HOW POWER FACTOR IS STORED IN THE REGISTER	122
HOW DATE AND TIME ARE STORED IN REGISTERS	123
REGISTER LISTING	124
APPENDIX B—USING THE COMMAND INTERFACE	199
CONTENTS	199
OVERVIEW OF THE COMMAND INTERFACE	200
Issuing Commands	201
I/O POINT NUMBERS	204
OPERATING OUTPUTS FROM THE COMMAND INTERFACE	205
USING THE COMMAND INTERFACE TO CHANGE CONFIGURATION REGISTERS	205
CONDITIONAL ENERGY	206
Command Interface Control	206
Digital Input Control	206
INCREMENTAL ENERGY	207
Using Incremental Energy	207
SETTING UP INDIVIDUAL HARMONIC CALCULATIONS	208
CHANGING SCALE FACTORS	209
GLOSSARY	211
INDEX	215

CHAPTER 1—INTRODUCTION

CHAPTER CONTENTS

CHAPTER CONTENTS	1
WHAT IS THE CIRCUIT MONITOR?	2
Accessories and Options for the Circuit Monitor	3
Features	3
TOPICS NOT COVERED IN THIS BULLETIN	4
FIRMWARE	4

This chapter offers a general description of the Series 3000 Circuit Monitor, tells how to best use this bulletin, and lists related documents.

WHAT IS THE CIRCUIT MONITOR?

The circuit monitor is a multifunction, digital instrumentation, data acquisition and control device. It can replace a variety of meters, relays, transducers and other components. The circuit monitor can be located at the service entrance to monitor the cost and quality of power, and can be used to evaluate the utility service. When located at equipment mains, the circuit monitor can detect voltage-based disturbances that cause costly equipment downtime.

The circuit monitor is equipped with RS-485 communications for integration into any power monitoring and control system. However, System Manager™ software (SMS) from POWERLOGIC, which is written specifically for power monitoring and control, best supports the circuit monitor's advanced features.

The circuit monitor is a true rms meter capable of exceptionally accurate measurement of highly nonlinear loads. A sophisticated sampling technique enables accurate, true rms measurement through the 63rd harmonic. You can view over 50 metered values plus extensive minimum and maximum data from the display or remotely using software. Table 1–1 summarizes the readings available from the circuit monitor.

Table 1–1: Summary of Circuit Monitor Instrumentation

Real-Time Readings	Energy Readings
<ul style="list-style-type: none"> • Current (per phase, N, G, 3-Phase) • Voltage (L–L, L–N, 3-Phase) • Real Power (per phase, 3-Phase) • Reactive Power (per phase, 3-Phase) • Apparent Power (per phase, 3-Phase) • Power Factor (per phase, 3-Phase) • Frequency • Temperature (internal ambient) • THD (current and voltage) • K-Factor (per phase) 	<ul style="list-style-type: none"> • Accumulated Energy, Real • Accumulated Energy, Reactive • Accumulated Energy, Apparent • Bidirectional Readings • Reactive Energy by Quadrant • Incremental Energy • Conditional Energy
Demand Readings	Power Analysis Values
<ul style="list-style-type: none"> • Demand Current (per phase present, 3-Phase avg.) • Demand Voltage (per phase present, 3-Phase avg.) • Average Power Factor (3-Phase total) • Demand Real Power (per phase present, peak) • Demand Reactive Power (per phase present, peak) • Demand Apparent Power (per phase present, peak) • Coincident Readings • Predicted Power Demands 	<ul style="list-style-type: none"> • Crest Factor (per phase) • Displacement Power Factor (per phase, 3-Phase) • Fundamental Voltages (per phase) • Fundamental Currents (per phase) • Fundamental Real Power (per phase) • Fundamental Reactive Power (per phase) • Harmonic Power • Unbalance (current and voltage) • Phase Rotation • Harmonic Magnitudes & Angles (per phase) • Sequence Components

Accessories and Options for the Circuit Monitor

The circuit monitor has a modular design to maximize its usability. In addition to the main meter, the circuit monitor has plug-in modules and accessories, including:

- **Remote display.** The optional remote 4-line display is available with a back-lit liquid crystal display (LCD) or a vacuum fluorescent display (VFD). The VFD model includes an infrared port that can be used to communicate directly with the circuit monitor from a laptop and can be used to download firmware, which keeps the circuit monitor up to date with the latest system enhancements.
- **Digital I/O Card.** You can further expand the I/O capabilities of the circuit monitor by adding a digital I/O card (4 inputs and 4 outputs). This card fits into the option slot on the top of the circuit monitor.
- **Ethernet Communications Card.** The Ethernet communications card provides an Ethernet port that accepts a 100 Mbps fiber optic cable or a 10/100 Mbps UTP and provides an RS-485 master port to extend the circuit monitor communications options. This card is easily installed into the option on the top of the circuit monitor.

Table 1–2 lists the circuit monitor parts and accessories and their associated instruction bulletins.

Table 1–2: Circuit Monitor Parts, Accessories, and Custom Cables

Description	Part Number	Document Number
Circuit Monitor	CM3250 CM3250MG	63230-300-200
	CM3350 CM3350MG	63230-301-200
VFD Display with infrared (IR) port and proximity sensor	CMDVF	63230-305-200
LCD Display	CMDLC	
Optical Communications Interface (for use with the VFD display only)	OCIVF	63230-306-200
Digital I/O Card Field installable with 4 digital inputs (120 Vac), 3 (10 A) relay outputs (120Vac), 1 pulse output (KYZ)	IOC44	63230-303-200
Ethernet Communications Card with 100 Mbps fiber or 10/100 Mbps UTP Ethernet port and 1 RS-485 master port	ECC21	63230-304-200
CM3 Mounting Adapter	CM3MA	63230-204-316 63230-400-212
CM3 L Adapter Plate	CM3LA	63230-400-211
4-ft display cable (1.2 m)	CAB-4	N/A
12-ft display cable (3.6 m)	CAB-12	
30-ft display cable (9.1 m)	CAB-30	
10-ft RS-232 cable (3 m)	CAB-106	

Features

Some of the circuit monitor’s many features include:

- True rms metering to the 63rd harmonic
- Accepts standard CT and PT inputs
- 600 volt direct connection on metering inputs

- Certified ANSI C12.20 revenue accuracy and IEC 60687 0.5S class revenue accuracy
- High accuracy—0.075% current and voltage (typical conditions)
- Min/max readings of metered data
- Power quality readings—THD, K-factor, crest factor
- Real-time harmonic magnitudes and angles to the 63rd harmonic
- Current and voltage sag/swell detection and recording (CM3350)
- Downloadable firmware
- Easy setup through the optional remote display (password protected) where you can view metered values
- Setpoint-controlled alarm and relay functions
- Onboard alarm and data logging
- Wide operating temperature range –25° to 70°C
- Flexible communications—RS-485 communications is standard, optional Ethernet communications card available with fiber optic connection
- One option card slot for field-installable I/O or Ethernet capabilities
- Standard 8MB onboard logging memory
- CT and PT wiring diagnostics
- Revenue security with utility sealing capability

TOPICS NOT COVERED IN THIS BULLETIN

Some of the circuit monitor's advanced features, such as onboard data logs and alarm log files, can only be set up over the communications link using SMS. SMS versions 3.3 and higher support the CM3000 device type. This circuit monitor instruction bulletin describes these advanced features, but does not tell how to set them up. For instructions on using SMS, refer to the SMS online help and the *SMS-3000 Setup Guide*, which is available in English, French, and Spanish. For information about related instruction bulletins, see Table 1–2 on page 3.

FIRMWARE

This instruction bulletin is written to be used with firmware version 12.200 or higher. See "Identifying the Firmware Version" on page 118 for instructions on how to determine the firmware version.

CHAPTER 2—SAFETY PRECAUTIONS

This chapter contains important safety precautions that must be followed before attempting to install, service, or maintain electrical equipment. Carefully read and follow the safety precautions outlined below.

⚠ DANGER

HAZARD OF ELECTRIC SHOCK, BURN, OR EXPLOSION

- Only qualified workers should install this equipment. Such work should be performed only after reading this entire set of instructions.
- NEVER work alone.
- Before performing visual inspections, tests, or maintenance on this equipment, disconnect all sources of electric power. Assume that all circuits are live until they have been completely de-energized, tested, and tagged. Pay particular attention to the design of the power system. Consider all sources of power, including the possibility of backfeeding.
- Turn off all power supplying this equipment before working on or inside.
- Always use a properly rated voltage sensing device to confirm that all power is off.
- Beware of potential hazards, wear personal protective equipment, carefully inspect the work area for tools and objects that may have been left inside the equipment.
- Use caution while removing or installing panels so that they do not extend into the energized bus; avoid handling the panels, which could cause personal injury.
- The successful operation of this equipment depends upon proper handling, installation, and operation. Neglecting fundamental installation requirements may lead to personal injury as well as damage to electrical equipment or other property.
- Before performing Dielectric (Hi-Pot) or Megger testing on any equipment in which the circuit monitor is installed, disconnect all input and output wires to the circuit monitor. High voltage testing may damage electronic components contained in the circuit monitor.

Failure to follow these instructions will result in death or serious injury.

CHAPTER 3—OPERATION

This chapter tells how to set up the circuit monitor from the display only. Some advanced features, such as configuring the onboard logs of the circuit monitor, must be set up over the communications link using SMS. Refer to the SMS instruction bulletin and online help file for instructions on setting up advanced features not accessible from the display.

CHAPTER CONTENTS

CHAPTER CONTENTS	7
OPERATING THE DISPLAY	8
How the Buttons Work	8
Display Menu Conventions	9
Selecting a Menu Option	9
Changing a Value	9
MAIN MENU OVERVIEW	10
CONFIGURING THE CIRCUIT MONITOR USING THE SETUP MENU ..	11
Setting Up the Display	11
Setting Up the Communications	12
Setting the Device Address	12
RS-485 and Infrared Port Communications Setup	13
Ethernet Communications Card (ECC) Setup	14
Redirecting the Port	14
Redirecting the IR Port to the ECC Subnet	14
Redirecting the IR Port to RS-485	16
Setting Up the Metering Functions of the Circuit Monitor	16
Setting Up Alarms	19
Creating a New Custom Alarm	20
Setting Up and Editing Alarms	21
Setting Up I/Os	24
Configuring I/O Modules	24
Setting Up Passwords	26
Advanced Setup Features	27
Creating Custom Quantities to be Displayed	27
Creating Custom Screens	30
Viewing Custom Screens	33
Advanced Meter Setup	33
RESETTING MIN/MAX, DEMAND, AND ENERGY VALUES	36
VIEWING METERED DATA	37
Viewing Metered Data from the Meters Menu	37
Viewing Minimum and Maximum Values from the Min/Max Menu ..	38
VIEWING ALARMS	40
Viewing Active Alarms	41
View and Acknowledging High Priority Alarms	41
VIEWING I/O STATUS	42
READING AND WRITING REGISTERS	43

PERFORMING A WIRING ERROR TEST 44
Running the Diagnostics Wiring Error Test 45

OPERATING THE DISPLAY

The display shows four lines of information at a time. Notice the arrow on the left of the display screen. This arrow indicates that you can scroll up or down to view more information. For example, on the Main Menu you can view the Resets, Setup, and Diagnostics menu options only if you scroll down to display them. When at the top of a list, the arrow moves to the top line. When the last line of information is displayed, the arrow moves to the bottom as illustrated in Figure 3–1.

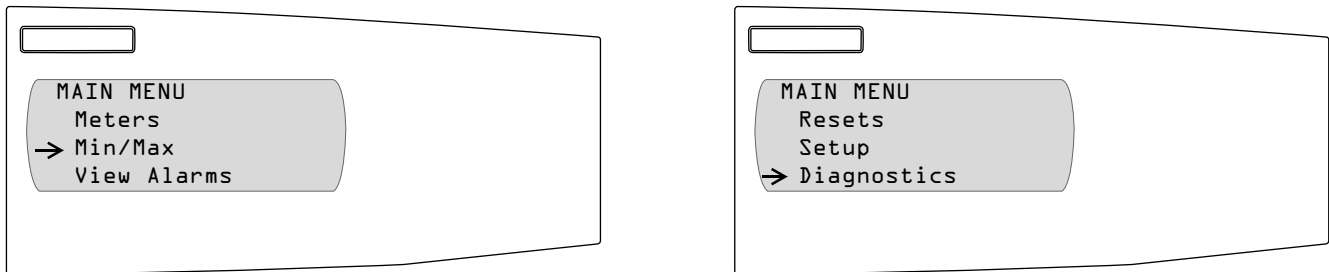

Figure 3–1: Arrow on the display screen

How the Buttons Work

The buttons on the display let you scroll through and select information, move from menu to menu, and adjust the contrast. Figure 3–2 shows the buttons.

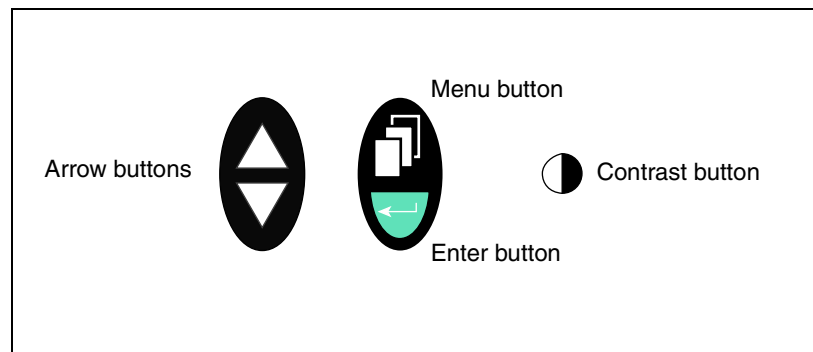

Figure 3–2: Display buttons

The buttons are used in the following way:

- **Arrow buttons.** Use the arrow buttons to scroll up and down the options on a menu. Also, when a value can be changed, use the arrow buttons to scroll through the values that are available. If the value is a number, holding the arrow button down increases the speed in which the numbers increase or decrease.
- **Menu button.** Each time you press the menu button, it takes you back one menu level. The menu button also prompts you to save if you've made changes to any options within that menu structure.
- **Enter button.** Use the enter button to select an option on a menu or select a value to be edited.

- **Contrast button.** Press the contrast button to darken or lighten the display. On the LCD model, press any button once to activate the back light.

Display Menu Conventions

This section explains a few conventions that were developed to streamline instructions in this chapter. Figure 3–3 shows the parts of a menu.

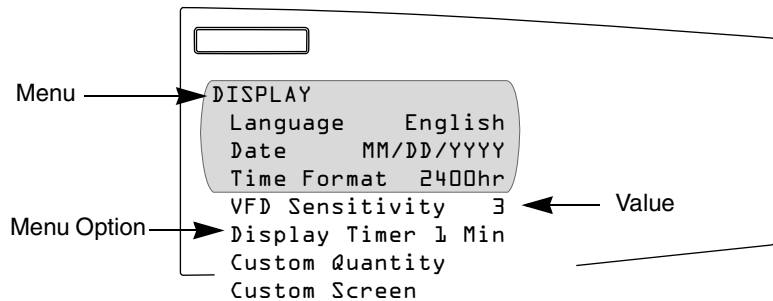



Figure 3–3: Parts of a menu



Selecting a Menu Option

Each time you read “select” in this manual, choose the option from the menu by doing this:

1. Press the arrows  to highlight the menu option.
2. Press the enter button  to select that option.

Changing a Value

To change a value, the procedure is the same on every menu:

1. Use the arrow buttons  to scroll to the menu option you want to change.
2. Press the enter button  to select the value. The value begins to blink.
3. Press the arrow buttons to scroll through the possible values. To select the new value, press the enter button.
4. Press the arrow buttons to move up and down the menu options. You can change one value or all of the values on a menu. To save the changes, press the menu button  until the circuit monitor displays: “Save changes? No”
NOTE: Pressing the menu button while a value is blinking will return that value to its most current setting.
5. Press the arrow to change to “Yes,” then press the enter button to save the changes.

MAIN MENU OVERVIEW

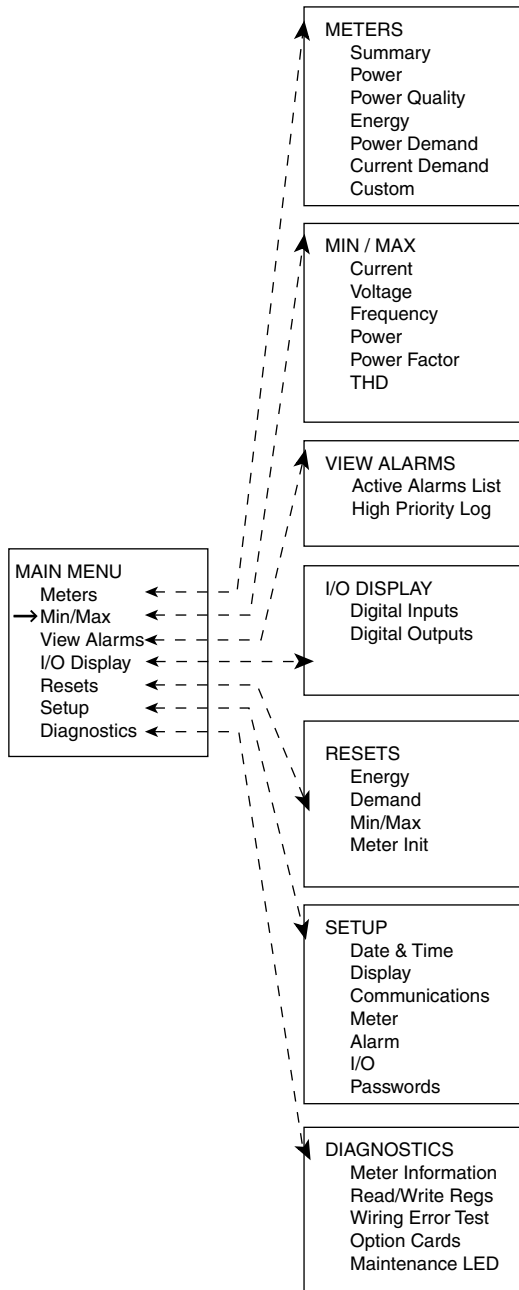

The Main Menu on the display contains the menu options that you use to set up and control the circuit monitor and its accessories and view metered data and alarms. Figure 3–4 on the left shows the options on the Main Menu. The menus are briefly described below:

- **Meters.** This menu lets you view metered values that provide information about power usage and power quality.
- **Min/Max.** This menu lets you view the minimum and maximum metered values since the last reset of the min/max values with their associated dates and times.
- **View Alarms.** This menu lets you view a list of all active alarms, regardless of the priority. In addition, you can view a log of high priority alarms, which contains the ten most recent high priority alarms.
- **I/O Display.** From this menu, you can view the designation and status of each input or output. This menu will only display the I/Os present, so you might not see all of the available menu items if you do not have a particular I/O installed.
- **Resets.** This menu lets you reset energy, peak demand, and minimum/maximum values.
- **Setup.** From this menu, you define the settings for the display such as selecting the date format to be displayed. Creating custom quantities and custom screens are also options on this menu. In addition, use this menu to set up the circuit monitor parameters such as the CT and PT ratios. The Setup menu is also where you define the communications, alarms, I/Os and passwords.
- **Diagnostics.** From this menu, you can initiate the wiring error test. Also, use this menu to read and write registers and view information about the circuit monitor such as its firmware version and serial number.

Figure 3–4: Menu options on the Main Menu

CONFIGURING THE CIRCUIT MONITOR USING THE SETUP MENU

Before you can access the Setup menu from the Main Menu, you must enter the Setup password. The default password is 0. To change the password, see “Setting Up Passwords” on page 26. The Setup menu has the following options:

- Date & Time
- Display
- Communications
- Meter
- Alarm
- I/O
- Passwords

Each of these options is described in the sections that follow.

Setting Up the Display

Setting up the display involves, for example, choosing a date and time format that you want to be displayed. To set up the display, follow these steps:

1. From the Main Menu, select Setup > Display.

The Display Setup menu displays. Table 3–1 describes the options on this menu.

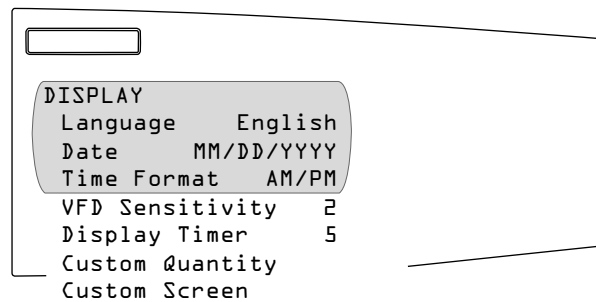

2. Use the arrow buttons to scroll to the menu option you want to change.
3. Press the enter button to select the value. The value begins to blink. Use the arrow buttons to scroll through the available values. Then, press the enter button to select the new value.
4. Use the arrow buttons to scroll through the other options on the menu, or if you are finished, press the menu button to save.

Table 3–1: Factory Defaults for the Display Settings

Option	Available Values	Selection Description	Default
Language	English Francais Espanol	Language used by the display.	English
Date	MM/DD/YYYY YYYY/MM/DD DD/MM/YYYY	Data format for all date-related values of the circuit monitor.	MM/DD/YYYY
Time Format	2400hr AM/PM	Time format can be 24-hour military time or 12-hour clock with AM and PM.	2400hr
VFD Sensitivity	Off 1 = 0–6 ft (0–15 m) 2 = 0–12 ft (0–31 m) 3 = 0–20 ft (0–51 m)	Sensitivity value for the proximity sensor (for the VFD display only).	2
Display Timer	1, 5, 10, or 15 minutes	Number of minutes the display remains illuminated after inactivity.	5
Custom Quantity	Creating custom quantities is an advanced feature that is not required for basic setup. To learn more about this feature, see “Creating Custom Quantities to be Displayed” on page 27.		
Custom Screen	Creating custom screens is an advanced feature that is not required for basic setup. To learn more about this feature, see “Creating Custom Screens” on page 30.		

Setting Up the Communications

The Communications menu lets you set up the following communications:

- *RS-485* communications for daisy-chain communication of the circuit monitor and other RS-485 devices.
- *Infrared Port* communications between the circuit monitor and a laptop computer (available only on the VFD display).
- *Ethernet Options* for Ethernet communications between the circuit monitor and your Ethernet network when an Ethernet Communications Card (ECC) is present.

Each of these options is described in the sections that follow.

Setting the Device Address

Each POWERLOGIC device on a communications link must have a unique device address. The term communications link refers to 1–32 POWERLOGIC compatible devices daisy-chained to a single communications port. If the communications link has only a single device, assign it address 1. By networking groups of devices, POWERLOGIC systems can support a virtually unlimited number of devices.

RS-485 and Infrared Port Communications Setup

To set up RS-485 or the infrared port communications, set the address, baud rate, and parity. Follow these steps:

1. From the Main Menu, select Setup > Communications.
The Communications Setup screen displays.

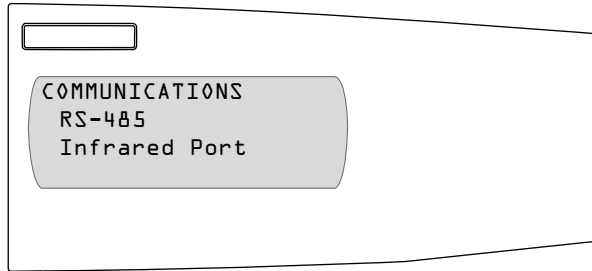

NOTE: You can set up infrared communications only if the circuit monitor is equipped with a VFD display. Also, you can set up Ethernet communications only if the circuit monitor is equipped with an ECC card.

2. From the Comms Setup menu, select the type of communications that you are using. Depending on what you select, the screen for that communications setup displays, as shown below. Table 3–2 describes the options on this menu.

RS-485	
Protocol	Modbus
Address	1
Baud Rate	9600
Parity	Even
Mode	Slave
Timeout (sec)	2

INFRARED PORT	
Protocol	Modbus
Address	1
Baud Rate	9600
Parity	Even
Redirect	Disabled

3. Use the arrow buttons to scroll to the menu option you want to change.
4. Press the enter button to select the value. The value begins to blink. Use the arrow buttons to scroll through the available values. Then, press the enter button to select the new value.
5. Use the arrow buttons to scroll through the other options on the menu, or if you are finished, press the menu button to save.

Table 3–2: Options for Communications Setup

Option	Available Values	Selection Description	Default
Protocol	MODBUS JBUS	Select MODBUS or JBUS protocol.	MODBUS
Address	1–255	Device address of the circuit monitor. See “Setting the Device Address” on page 12 for requirements of device addressing.	1

Table 3–2: Options for Communications Setup

Baud Rate	1200 2400 4800 9600 19200 38400	Speed at which the devices will communicate. The baud rate must match all devices on the communications link.	9600
Parity	Even, Odd, or None	Parity at which the circuit monitor will communicate.	Even

Ethernet Communications Card (ECC) Setup

Ethernet communications is available only if you have an optional Ethernet Communications Card (ECC) that fits into the option slot on the top of the circuit monitor. See “Option Cards” in **Chapter 4—Installation** of the installation manual for more information. To set up the Ethernet communications between the circuit monitor and the network, refer to instruction bulletin no. 63230-304-200 provided with the ECC.

Redirecting the Port

The port redirect feature lets you communicate to devices on a subnetwork through the infrared (IR) port of the display or the RS-232 port of your circuit monitor. You can redirect the following ports:

- Redirect the IR port to the RS-485.
- Redirect the IR port to the ECC RS-485 subnetwork.

This feature can be especially useful for communication to non-Modbus devices on a mixed-mode daisy chain connected to the circuit monitor. For example, if your circuit monitor is equipped with an ECC21 (Ethernet Communications Card), you can use this feature to communicate to non-Modbus devices such as a Series 2000 Circuit Monitor on a subnetwork.

Redirecting the IR Port to the ECC Subnet

Redirecting the IR port to the ECC lets you communicate from your PC to devices on the ECC RS-485 subnet through the IR port as shown in Figure 3–5. You'll need the Optical Communication Interface (OCIVF) to communicate through the IR port. This configuration is useful in larger systems.

To redirect the IR port, select Setup > Communications > Infrared Port> Redirect to Subnet. Save your changes.

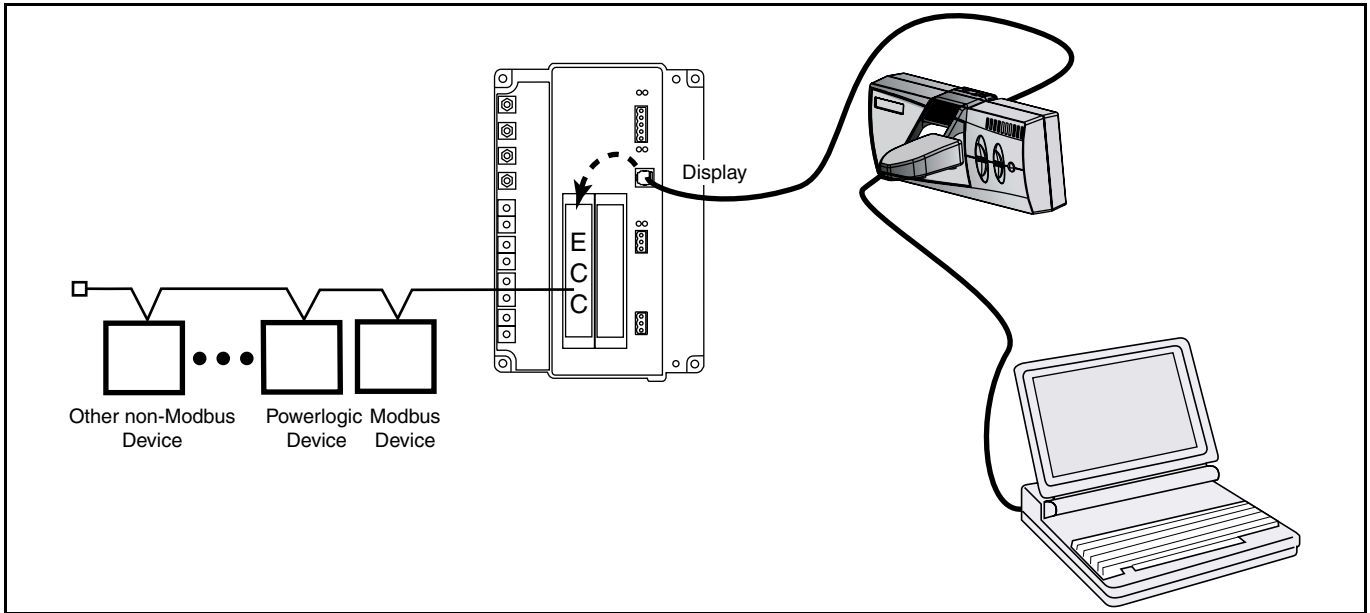

Figure 3-5: Redirected IR port to the ECC RS-485 subnet

Redirecting the IR Port to RS-485

Redirecting the IR port of the display to the RS-485 port lets you communicate from your PC to devices on the RS-485 daisy chain, without having a direct PC to RS-485 connection. You'll need the Optical Communication Interface (OCIVF) to communicate through the IR port. Figure 3-6 illustrates this connection. This configuration is useful in smaller systems.

Follow these steps:

1. Set the RS-485 port to "Master" before redirecting the IR port to the RS-485 port. From the Main Menu of the display, select Setup > Communications > RS-485 > Mode > Master.

NOTE: If the RS-485 port is not set to Master, the circuit monitor will disable the redirect of the RS-232 port.

2. To redirect the IR port, from the Communications menu, select Infrared Port> Redirect to RS-485. Save your changes.

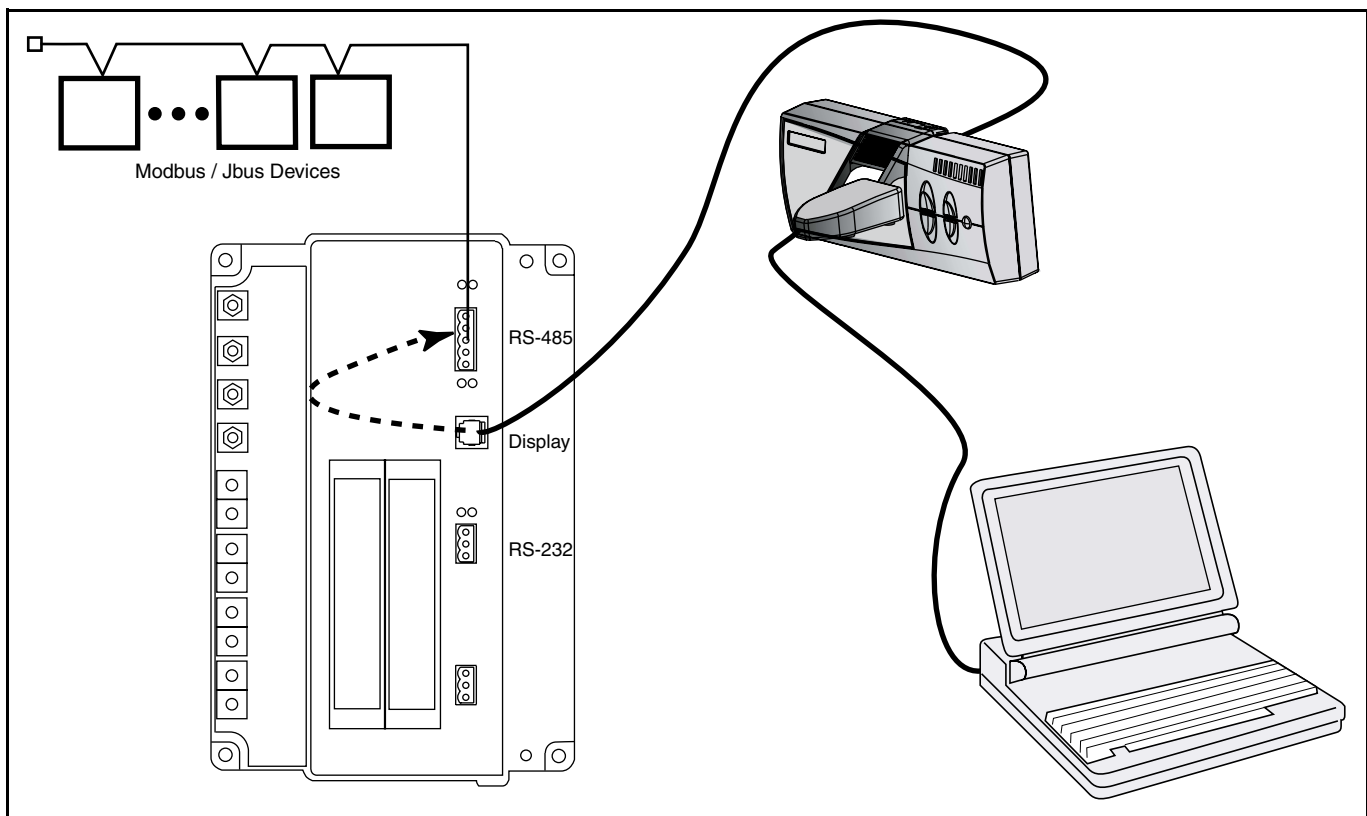

Figure 3-6: Redirected IR port to the RS-485

Setting Up the Metering Functions of the Circuit Monitor

To set up the metering within the circuit monitor, you must configure the following items on the Meter setup screen for basic setup:

- CT and PT ratios
- System type
- Frequency

The power demand method, interval and subinterval, and advanced setup options are also accessible from the Meter Setup menu, but are not required for basic setup if you are accepting the factory defaults already defined in the circuit monitor. Follow these steps to set up the circuit monitor:

1. From the Main Menu, select Setup > Meter.

The Meter setup screen displays. Table 3–3 describes the options on this menu.

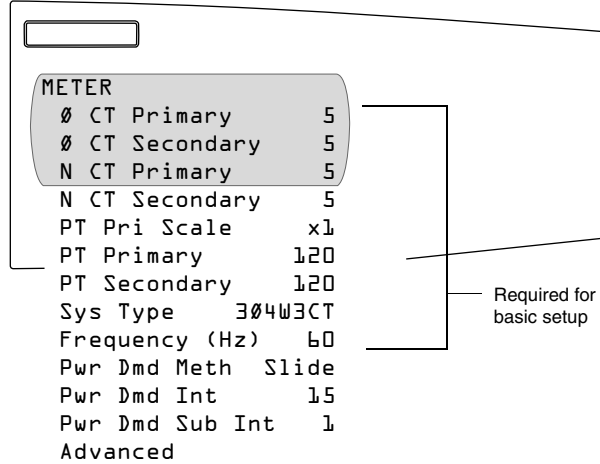

2. Use the arrow buttons to scroll to the menu option you want to change.
3. Press the enter button to select the value. The value begins to blink. Use the arrow buttons to scroll through the available values. Then, press the enter button to select the new value.
4. Use the arrow buttons to scroll through the other options on the menu, or if you are finished, press the menu button to save.

Table 3–3: Options for Meter Setup

Option	Available Values	Selection Description	Default
CT Primary	1–32,767	Set the rating for the CT primary. The circuit monitor supports two primary CT ratings: one for the phase CTs and the other for the neutral CT.	5
CT Secondary	1 or 5	Set the rating for the CT secondaries.	5
PT Pri Scale	x1 x10 x100 No PT	Set the value to which the PT Primary is to be scaled if the PT Primary is larger than 32,767. For example, setting the scale to x10 multiplies the PT Primary number by 10. For a direct-connect installation, select “No PT.”	x1
PT Primary	1–32,767	Set the rating for the PT primary.	120
PT Secondary	100 110 115 120	Set the rating for the PT secondaries.	120
Sys Type	3Ø3W2CT 3Ø3W3CT 3Ø4W3CT 3Ø4W4CT 3Ø4W3CT2PT 3Ø4W4CT2PT	3Ø3W2CT is system type 30 3Ø3W3CT is system type 31 3Ø4W3CT is system type 40 3Ø4W4CT is system type 41 3Ø4W3CT2PT is system type 42 3Ø4W4CT2PT is system type 43 Set the system type. A system type code is assigned to each type of system connection. See Table 5–2 in the installation manual for a description of system connection types.	3Ø4W3CT (40)
Frequency (Hz)	50, 60, or 400 Hz	Frequency of the system.	60
Pwr Dmd Meth	Select the power demand calculation method. The circuit monitor supports several methods to calculate average demand of real power. See “Demand Power Calculation Methods” on page 55 for a detailed description. Slide—Sliding Block Demand Slave—Slave Block Demand Therm—Thermal Demand RComms—Command-Synchronized Rolling Block Demand Comms—Command-Synchronized Block Demand RInput—Input-Synchronized Rolling Block Demand Input—Input-Synchronized Block Demand RClock—Clock-Synchronized Rolling Block Demand Clock—Clock-Synchronized Block Demand RBlock—Rolling Block Demand Block—Fixed Block Demand IncEngy—Synch to Incremental Energy Interval		Slide
Pwr Dmd Int	1–60	Power demand interval—set the time in minutes in which the circuit monitor calculates the demand.	15
Pwr Dmd Sub Interval	1–60	Power demand subinterval—period of time within the demand interval in which the demand calculation is updated. Set the subinterval only for methods that will accept a subinterval. The subinterval must be evenly divisible into the interval.	N/A
Advanced	See “Advanced Meter Setup” on page 33 in this chapter for more information.		

Setting Up Alarms

This section describes how to setup alarms and create your own custom alarms. For a detailed description of alarm capabilities, see **Chapter 6—Alarms** on page 77. The circuit monitor can detect over 100 alarm conditions, including over/under conditions, status input changes, phase unbalance conditions, and more. Some alarms are preconfigured and enabled at the factory. See “Factory Defaults” in **Chapter 3—Getting Started** of the installation manual for information about preconfigured alarms. You can edit the parameters of any preconfigured alarm from the display.

For each alarm that you set up, do the following:

- Select the alarm group that defines the type of alarm:
 - *Standard speed* alarms have a detection rate of one second and are useful for detecting conditions such as over current and under voltage. Up to 80 alarms can be set up in this group.
 - *High speed* alarms have a detection rate of 100 milliseconds and are useful for detecting voltage sags and swells that last a few cycles. Up to 20 alarms can be set up in this group.
 - *Disturbance monitoring* alarms have a detection rate of less than one cycle and are useful for detecting voltage sags and swells. Up to 20 alarms can be set up in this group. (CM3350 only)
 - *Digital* alarms are triggered by an exception such as the transition of a status input or the end of an incremental energy interval. Up to 40 alarms can be set up in this group.
 - *Boolean* alarms have a detection rate of the alarms used as inputs. They are used to combine specific alarms into summary alarm information.
- Select the alarm that you want to configure. Keep the default name or enter a new name with up to 15 characters.
- Enable the alarm.
- Assign a priority to the alarm. Refer to “Viewing Alarms” on page 40 for information about the alarm priority levels.
- Define any required pickup and dropout setpoints, and pickup and dropout time delays (for standard, high speed, and disturbance alarm groups only, refer to “Setpoint-Driven Alarms” on page 79 in **Chapter 6—Alarms**).

Creating a New Custom Alarm

In addition to editing an alarm, you can also create new custom alarms by performing these steps:

1. Create the custom alarm.
2. Setup the new alarm.
3. Enable the new alarm.

The recommended sequence is to set up the alarm and save the settings while the alarm is disabled. Then, go back into setup to enable the alarm. You can enable and disable alarms at any time. However, if an alarm is set up and enabled in the same setup session, the alarm will be enabled for a short length of time with the previous settings. This could result in a seemingly “false alarm” with unexpected consequences if the alarm operates an associated relay.

To use custom alarms, you must first create a custom alarm and then set up the alarm to be used by the circuit monitor. Creating an alarm defines information about the alarm including:

- Alarm group (standard, high speed, disturbance, digital, or boolean)
- Name of the alarm
- Type (such as whether it alarms on an over or under condition)
- Register number of the value that will be alarmed upon

To create an alarm, follow these steps:

1. From the Main Menu, select Setup > Alarm > Create Custom.
The Create Custom screen displays.

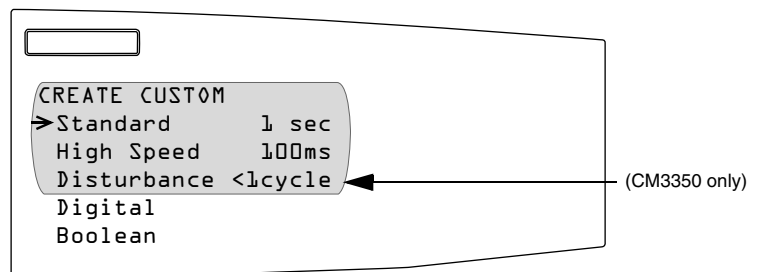

2. Select the Alarm Group for the alarm that you are creating:
 - Standard—detection rate of 1 second
 - High Speed—detection rate of 100 millisecond
 - Disturbance—detection rate of less than 1 cycle (CM3350 only)
 - Digital—triggered by an exception such as a status input or the end of an interval
 - Boolean—triggered by condition of alarms used as inputs

The Select Position screen displays and jumps to the first open position in the alarm list.

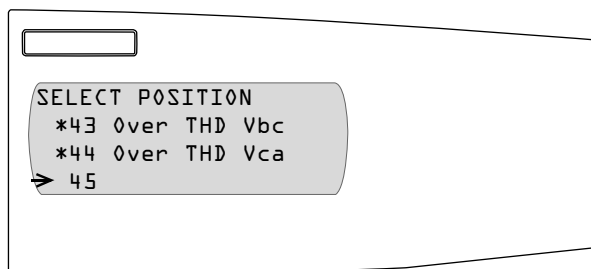

3. Select the position of the new alarm.
The Alarm Parameters screen displays.

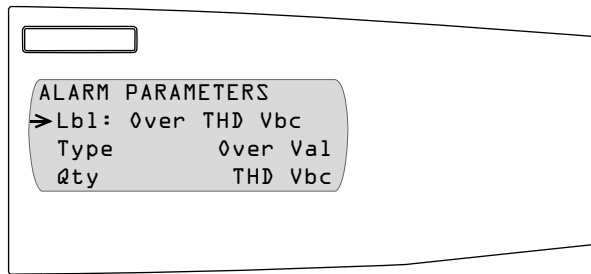

Table 3–4 on page 21 describes the options on this menu.

Table 3–4: Options for Creating an Alarm

Option	Available Values	Selection Description	Default
Lbl	Alphanumeric	Label—name of the alarm. Press the down arrow button to scroll through the alphabet. The lower case letters are presented first, then uppercase, then numbers and symbols. Press the enter button to select a letter and move to the next character field. To move to the next option, press the menu button.	—
Type	<p>Select the type of alarm that you are creating. <i>Note: For digital alarms, the type is either ON state, OFF state, or Unary to describe the state of the digital input. Unary is available for digital alarms only.</i> ① Over Val—over value Over Pwr—over power Over Rev Pwr—over reverse power Under Val—under value Under Pwr—under power Phs Rev—phase reversal Phs Loss Volt—phase loss, voltage Phs Loss Cur—phase loss, current PF Lead—leading power factor PF Lag—lagging power factor See Table 6–4 on page 90 for a description of alarm types.</p>	Undefined	
Qty	<p>For standard or high speed alarms this is the quantity to be evaluated. While selected, press the arrow buttons to scroll through the following quantity options: Current, Voltage, Demand, Unbalance, Frequency, Power Quality, THD, Harmonics, Temperature, Custom, and Register. Pressing the menu key while an option is displayed will activate that option's list of values. Use the arrow keys to scroll through the list of options, selecting an option by pressing the enter key.</p>	Undefined	

① Unary is a special type of alarm used for "end of" digital alarms. It does not apply to setting up alarms for digital inputs.

4. Press the menu button until "Save Changes? No" flashes on the display. Select Yes with the arrow button, then press the enter button to save the changes. Now, you are ready to set up the newly created custom alarm.

Setting Up and Editing Alarms

To set up a newly created custom alarm for use by the circuit monitor, use the Edit Parameters option on the Alarm screen. You can also change parameters of any alarm, new or existing. For example, using the Edit option you can enable or disable an alarm, change its priority, and change its pickup and dropout setpoints.

Follow these instructions to set up or edit an alarm:

- From the Main Menu, select Setup > Alarm > Edit Parameters.
 The Edit Parameters screen displays.

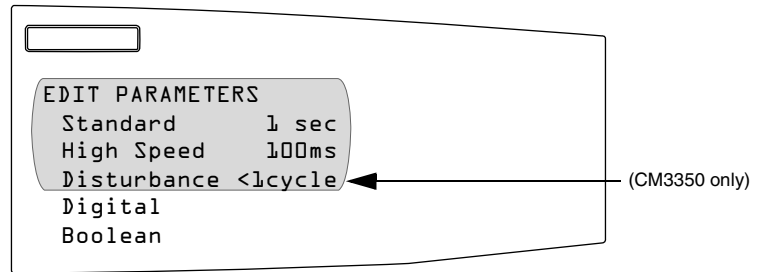

- Select the Alarm Group:
 - Standard
 - High Speed
 - Disturbance (CM3350 only)
 - Digital
 - Boolean

The Select Alarm screen displays.

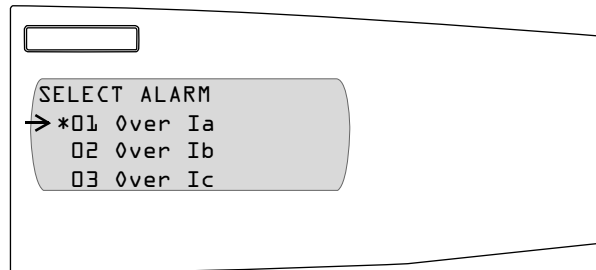

NOTE: If you are setting up or editing a digital alarm, alarm names such as Breaker 1 trip, Breaker 1 reset will display instead.

- Select the alarm you want to set up or edit.
 The Edit Alarm screen with the alarm parameters displays. Table 3–5 describes the options on this menu.

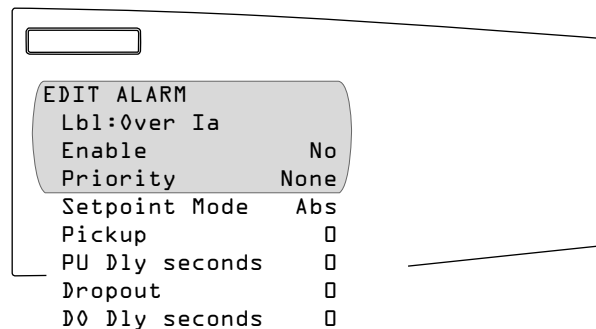

NOTE: If you are setting up or editing a digital alarm, fields related to pickup and dropout are not applicable and will not be displayed.

- Use the arrow buttons to scroll to the menu option you want to change, then edit the alarm options.

5. When you are finished with all changes, press the menu button until “Save Changes? No” flashes on the display. Select Yes with the arrow button, then press the enter button to save the changes.

NOTE: An asterisk next to the alarm in the alarm list indicates that the alarm is enabled.

Table 3–5: Options for Editing an Alarm

Option	Available Values	Selection Description	Default
Lbl	Alphanumeric	Label—name of the alarm assigned to this position. Press the down arrow button to scroll through the alphabet. The lower case letters are presented first, then uppercase, then numbers and symbols. Press the enter button to select a letter and move to the next character field. To move to the next option, press the menu button.	Name of the alarm assigned to this position.
Enable	Yes No	Select <i>Yes</i> to make the alarm available for use by the circuit monitor. On preconfigured alarms, the alarm may already be enabled. Select <i>No</i> to makes the alarm function unavailable to the circuit monitor.	Depends on individual alarm.
Priority	None Low Med High	<i>Low</i> is the lowest priority alarm. <i>High</i> is the highest priority alarm and also places the active alarm in the list of high priority alarms. To view this list from the Main Menu, select Alarms > High Priority Alarms. For more information, see “Viewing Alarms” on page 40.	Depends on individual alarm.
Setpoint Mode	Abs Rel	Selecting Abs indicates that the pickup and dropout setpoints are absolute values. Rel indicates that the pickup and dropout setpoints are a percentage of a running average, the relative value, of the test value.	
Pickup	1–32,767	When you enter a delay time, the number is multiples of time. For example, for standard speed the time is 2 for 2 seconds, 3 for 3 seconds, etc. For high speed alarms, 1 indicates a 100 ms delay, 2 indicates a 200 ms delay, and so forth. For disturbance the time unit is 1 cycle. See “Setpoint-Driven Alarms” on page 79 for an explanation of pickup and dropout setpoints.	Depends on individual alarm.
PU Dly Seconds	Pickup Delay 1–32,767		
Dropout	1–32,767		
DO Dly Seconds	Dropout Delay 1–32,767		

Setting Up I/Os

To set up an I/O, you must do the following:

1. Install the I/O option card following the instructions provided with the product.
2. Use the display to configure each individual input and output. You can also use SMS to configure inputs and outputs.

Configuring I/O Modules

Follow the steps below to configure the inputs and outputs for the I/O card you installed.

1. From the Main Menu, select Setup.
The password prompt displays
2. Select your password. The default password is 0.
The Setup menu displays.

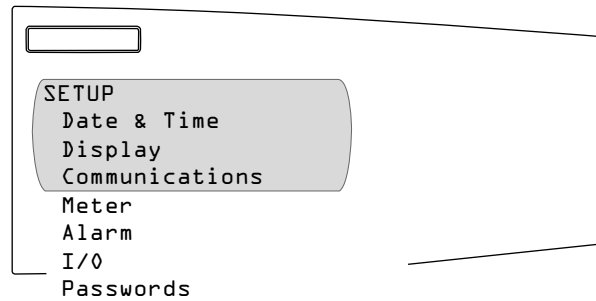

3. Select I/O.
The I/O Setup menu displays.

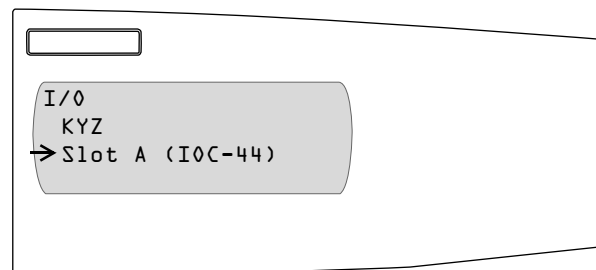

4. Select the I/O option that you have installed. In this example, we selected the IOC-44.
The IOC-44 Setup menu displays.

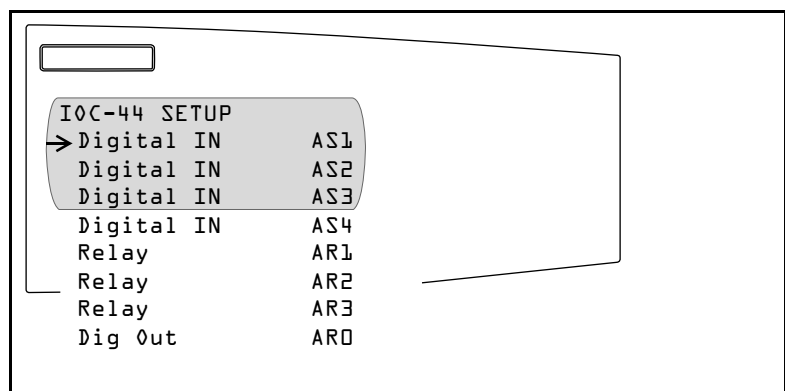

5. Select the position in the IOC-44 you wish to install.
The I/O setup menu displays based on the type of I/O installed in the selected position.

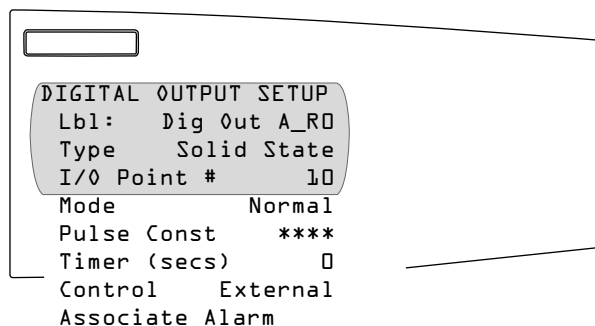
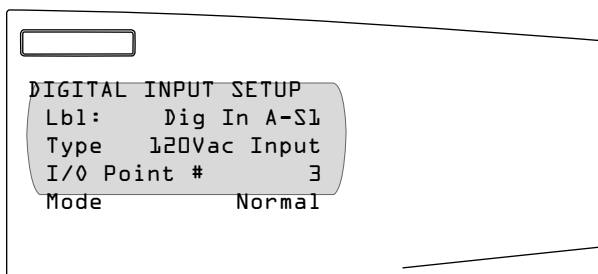

NOTE: For a description of the I/O options displayed above, refer to **Chapter 5—Input/Output Capabilities** on page 67.

Setting Up Passwords

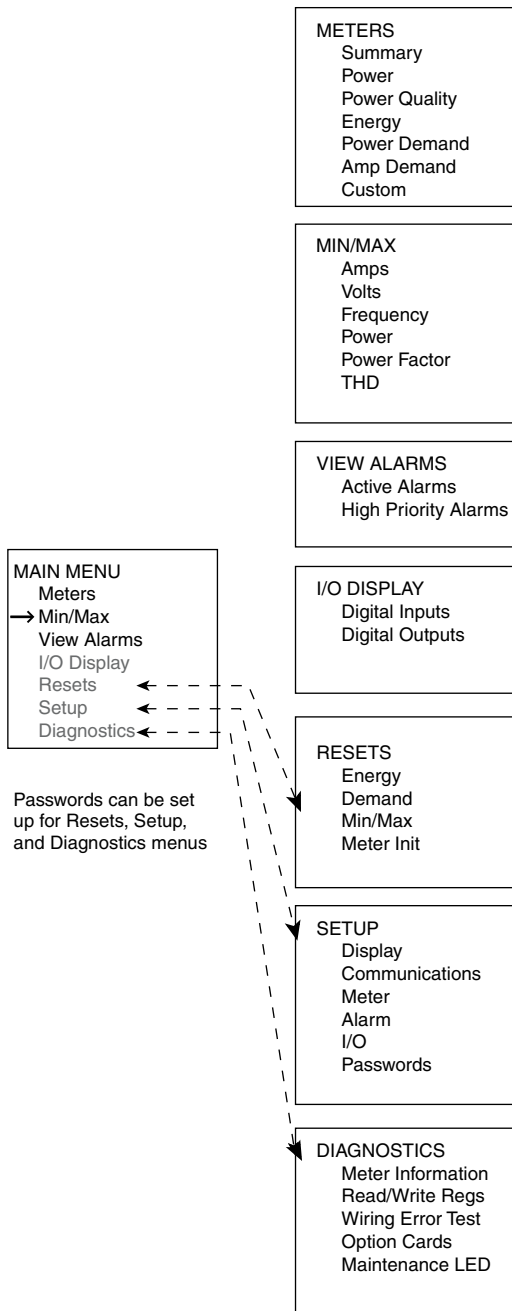

A password is always required to access the following menus from the Main Menu:

- Resets (a separate password can be set up for Energy/Demand Reset and Min/Max Reset)
- Setup
- Read/Write Regs on the Diagnostics Menu

The default password is 0. Therefore, when you receive a new circuit monitor, the password for the Setup, Diagnostics, and Reset menu is 0. If you choose to set up passwords, you can set up a different password for each of the four menu options listed above.

To set up a password, follow these instructions:

1. From the Main Menu, select Setup.
The password prompt displays.
2. Select 0, the default password.
The Setup menu displays.

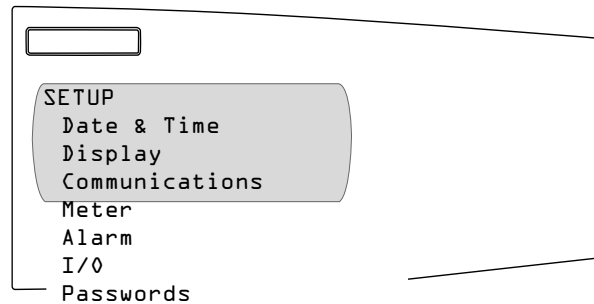

3. Select Passwords.
The Password Setup menu displays. Table 3–6 describes the options.

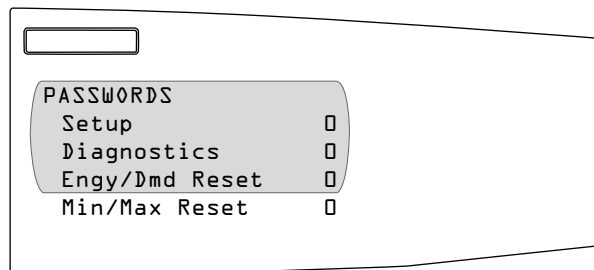

Figure 3–7: Menus that can be password protected

Table 3–6: Options for Password Setup

Option	Available Values	Description
Setup	0–9998	Enter a password in the Setup field to create a password for the Setup option on the Main Menu.
Diagnostics	0–9998	Enter a password in the Diagnostics field to create a password for the Diagnostics option on the Main Menu.

Table 3–6: Options for Password Setup

Engy/Dmd Reset ^①	0–9998	Enter a password in the Engy/Dmd Reset field to create a password for resetting Energy and Demand. These options appear on the Reset menu, and they can also be locked. See “Advanced Meter Setup” on page 33 for instructions.
Min/Max Reset ^①	0–9998	Enter a password in the Min/Max Reset field to create a password for resetting the Min/Max, which appears on the Reset menu. This option can also be locked. See “Advanced Meter Setup” on page 33 for instructions.

^①The word “Locked” appears next to a reset option that is inaccessible. If all of the reset options are locked, “Locked” will appear next to the Resets option in the Main Menu, and the Resets menu will be inaccessible.

Advanced Setup Features

The features discussed in this section are not required for basic circuit monitor setup, but can be used to customize your circuit monitor to suit your needs.

Creating Custom Quantities to be Displayed

Any quantity that is stored in a register in the circuit monitor can be displayed on the remote display. The circuit monitor has a list of viewable quantities already defined such as average current, power factor total, and so forth. In addition to these predefined values, you can define custom quantities that can be displayed on a custom screen. For example, if your facility uses different types of utility services such as water, gas, and steam, you may want to track usage of the three services on one convenient screen. To do this, you could set up inputs to receive pulses from each utility meter, then display the scaled register quantity.

For the circuit monitor display, custom quantities can be used to display a value. Don’t confuse this feature with SMS custom quantities. SMS custom quantities are used to add new parameters which SMS can use to perform functions. SMS custom quantities are defined, for example, when you add a new POWERLOGIC-compatible device to SMS or if you want to import data into SMS from another software package. You can use the SMS custom quantities in custom tables and interactive graphics diagrams, but you cannot use circuit monitor display custom quantities in this way. *Custom quantities that you define for display from the circuit monitor are not available to SMS. They must be defined separately in SMS.*

To use a custom quantity, perform these tasks:

1. **Create the custom quantity** as described in this section.
2. **Create a custom screen** on which the custom quantity can be displayed. See “Creating Custom Screens” on page 30 in the following section. You can view the custom screen by selecting from the Main Menu, Meters > Custom. See “Viewing Custom Screens” on page 33 for more information.

To create a custom quantity, follow these steps:

1. From the Main Menu, select Setup.
The password prompt displays.
2. Select your password. The default password is 0.
The Setup menu displays.

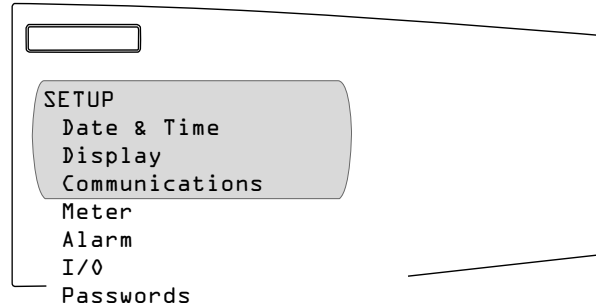

3. Select Display.
The Display Setup menu displays.

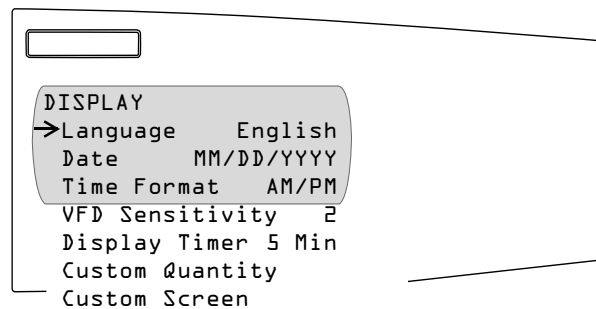

4. Select Custom Quantity.
The Custom Quantity Setup screen displays.

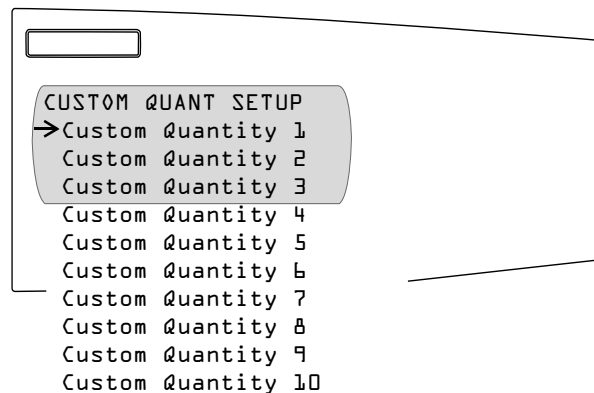

5. Select a custom quantity.

In this example, we selected Custom Quantity 1. Table 3–7 shows the available values.

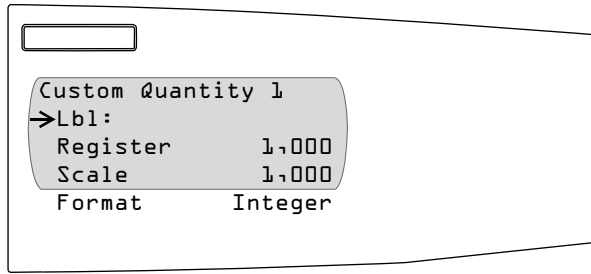

6. Use the arrow buttons to scroll to the menu option you want to change.
7. Press the enter button to select the value. The value begins to blink. Use the arrow buttons to scroll through the available values. Then, press the enter button to select the new value.
8. Use the arrow buttons to scroll through the other options on the menu, or if you are finished, press the menu button to save.

Table 3–7: Options for Custom Quantities

Option	Available Values	Default
Lbl	Name of the quantity up to 10 characters. Press the arrow buttons to scroll through the characters. To move to the next option, press the menu button.	
Register	4- or 5-digit number of the register in which the quantity exists.	1,000
Scale	Multiplier of the register value can be one of the following: .001, .01, .1, 1.0, 10, 100 or 1,000. See "Scale FactorS" on page 85 for more information.	1,000
Format	Integer D/T—date and time MOD10L4—Modulo 10,000 with 4 registers ^① MOD10L3—Modulo 10,000 with 3 registers ^① MOD10L2—Modulo 10,000 with 2 registers ^① Label ^② Text	Integer

^① Modulo 10,000 is used to store energy. See the SMS online help for more.
^② Use the Label format to create a label with no corresponding data register.

An asterisk (*) next to the quantity indicates that the quantity has been added to the list.

9. To save the changes to the Display Setup screen, press the menu button.

The custom quantity is added to the Quantities List in the Custom Screen Setup. The new quantity appears at the end of this list after the standard quantities. After creating the custom quantity, you must create a custom screen to be able to view the new quantity.

Creating Custom Screens

You choose the quantities that are to be displayed on a custom screen. The quantities can be standard or custom quantities. If you want to display a custom quantity, you must first create the custom quantity so that it appears on the Quantities List. See “Creating Custom Quantities to be Displayed” on page 27 for instructions.

To create a custom screen, follow these steps:

1. From the Main Menu, select Setup.
The password prompt displays.
2. Select your password. The default password is 0.
The Setup menu displays.

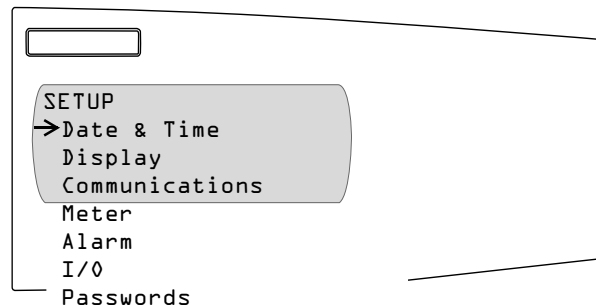

3. Select Display.
The Display Setup menu displays.

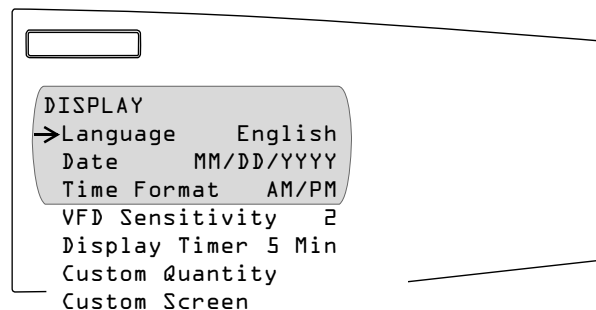

4. Select Custom Screen.
The Custom Screen Setup screen displays.

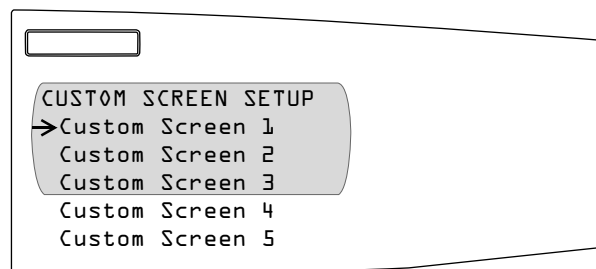

5. Select a custom screen.
In this example, we selected Custom Screen 1.

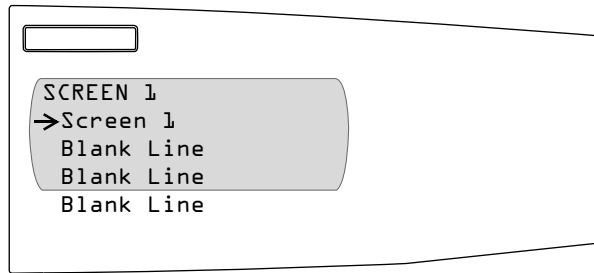

Press the enter button. The cursor begins to blink.

6. Create a name for the custom screen. Press the arrow buttons to scroll through the alphabet. Press the enter button to move to the next character field.
7. When you have finished naming the screen, press the menu button, then select the first blank line.

The first blank line begins to blink.

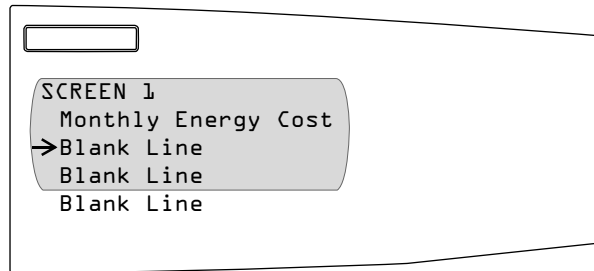

8. Press the menu button. Use the arrow buttons to select one of the following quantity types:

- Current
- Voltage
- Frequency
- Power Factor
- Power
- THD
- Energy
- Demand
- Harmonics
- Unbalance
- Custom

To view the quantities of a quantity type, press the enter button.

The first quantity flashes on the display.

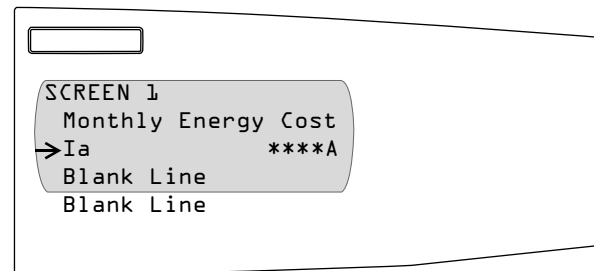

9. Use the arrow buttons to scroll through the list of quantities. Select the quantity that you want for your custom screen by pressing the enter button.

Table 3–8 lists the default quantities. If you have created a custom quantity, it will be displayed at the bottom of this list.

Table 3–8: Available Default Quantities

Quantity Type	Quantity	Label [®]
Current	Current A	Ia
	Current B	Ib
	Current C	Ic
	Current N	In
	Current G	Ig
	Current Average	I Avg
Voltage	Voltage A–B	Vab
	Voltage B–C	Vbc
	Voltage C–A	Vca
	Voltage L–L Average	V L-L Avg
	Voltage A–N	Van
	Voltage B–N	Vbn
	Voltage C–N	Vcn
	Voltage L–N Average	V L-N Avg
Frequency	Frequency	Freq
Power Factor	Power Factor Total	PF Total
	Displacement Power Factor Total	Dis PF Tot
Power	Real Power Total	kW Total
	Reactive Power Total	kVAR Total
	Apparent Power Total	kVA Total
THD	THD Current A	THD Ia
	THD Current B	THD Ib
	THD Current C	THD Ic
	THD Current N	THD In
	THD Voltage A–N	THD Van
	THD Voltage B–N	THD Vbn
	THD Voltage C–N	THD Vcn
	THD Voltage A–B	THD Vab
	THD Voltage B–C	THD Vbc
	THD Voltage C–A	THD Vca
Energy	Real Energy, Total	kWhr Tot
	Reactive Energy, Total	kVARHr Tot
	Apparent Energy, Total	kVAHr Tot
Demand	Demand Current Average	Dmd I Avg
	Demand Current A	Dmd Ia
	Demand Current B	Dmd Ib
	Demand Current C	Dmd Ic
	Demand Current N	Dmd In
	Demand Voltage A–N	Dmd Van
	Demand Voltage B–N	Dmd Vbn
	Demand Voltage C–N	Dmd Vcn
	Demand Voltage L–N Average	Dmd V L-N
	Demand Voltage A–B	Dmd Vab
	Demand Voltage B–C	Dmd Vbc
	Demand Voltage C–A	Dmd Vca

Table 3–8: Available Default Quantities

Quantity Type	Quantity	Label [ⓐ]
	Demand Voltage L-L Avg	Dmd V L-L
	Demand Real Power (kWD)	Dmd kW
	Demand Reactive Power (kVARD)	Dmd kVAR
	Demand Apparent Power (kVA)	Dmd kVA
Harmonics	3rd Harmonic Magnitude Voltage A	Van 3rd
	5th Harmonic Magnitude Voltage A	Van 5th
	7th Harmonic Magnitude Voltage A	Van 7th
	3rd Harmonic Magnitude Voltage B	Vbn 3rd
	5th Harmonic Magnitude Voltage B	Vbn 5th
	7th Harmonic Magnitude Voltage B	Vbn 7th
	3rd Harmonic Magnitude Voltage C	Vcn 3rd
	5th Harmonic Magnitude Voltage C	Vcn 5th
	7th Harmonic Magnitude Voltage C	Vcn 7th
Unbalance	Current Unbalance Max	I Unbl Mx
	Voltage Unbalance Max L-L	V Unbl Mx L-L
	Voltage Unbalance Max L-N	V Unbl Mx L-N

[ⓐ] Displayed on the screen.

10. Press the menu button until “Save Changes? No” flashes on the display. Select Yes, then press the enter button to save the custom screen.

Viewing Custom Screens

If you have a custom screen setup, a “Custom” option will be displayed on the Meters menu.

To view a custom screen, from the Main Menu select Meters > Custom. In this example, a custom screen was created for monthly energy cost. Press the arrow button to view the next custom screen. Press the menu button to exit and return to the Meters Menu.

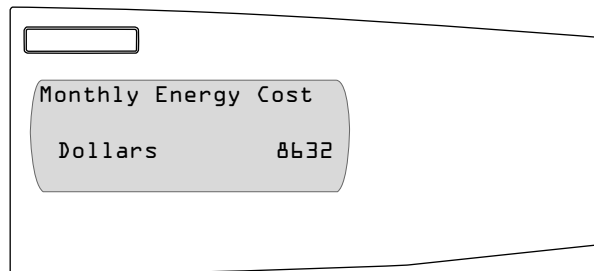

Advanced Meter Setup

The Advanced option on the Meter Setup screen lets you perform miscellaneous advanced setup functions on the metering portion of the circuit monitor. For example, on this menu you can change the phase rotation or the VAR sign convention. The advanced options are described below.

1. From the Main Menu, select Setup.
The password prompt displays.
2. Select your password. The default password is 0.
The Setup menu displays.

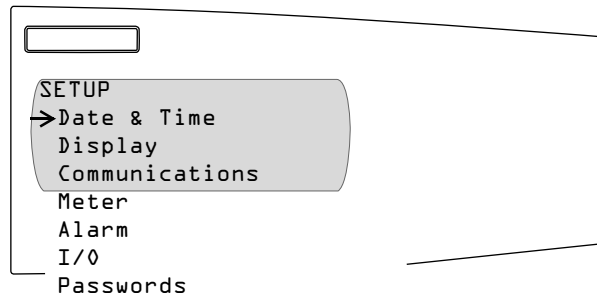

3. Select Meter.
The Meter Setup screen displays.

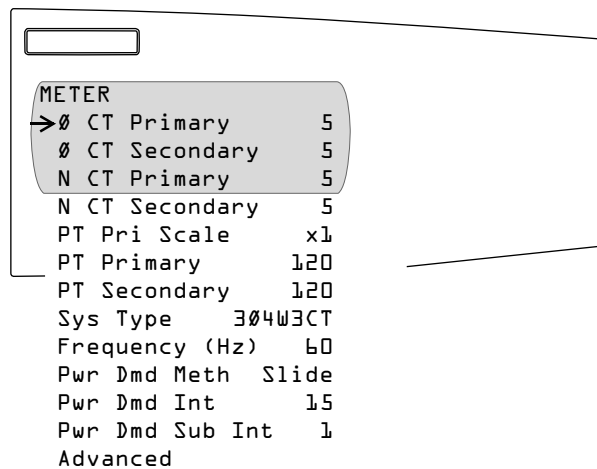

4. Scroll to the bottom of the list and select Advanced.
The Advanced Meter Setup screen displays. Table 3–9 on page 35 describes the options on this menu.

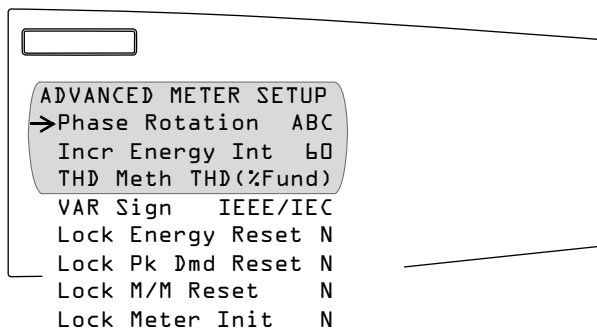

5. Change the desired options and press the menu button to save.

Table 3–9: Options for Advanced Meter Setup

Option	Available Values	Selection Description	Default
Phase Rotation	ABC or CBA	Set the phase rotation to match the system.	ABC
Incr Energy Int	0–1440	Set incremental energy interval in minutes. The interval must be evenly divisible into 24 hours.	60
THD Meth	THD(%Fund) or thd(%RMS)	Set the calculation for total harmonic distortion. See “Power Analysis Values” on page 64 for a detailed description.	THD
VAR Sign	IEEE/IEC or ALT(CM1)	Set the VAR sign convention. See “VAR Sign Conventions” on page 53 for a discussion about VAR sign convention.	Standard
Lock Energy Reset	Y or N	Lock the reset of the accumulated energy. If set to Y (yes), the Energy option on the Reset menu will be locked so that the value cannot be reset from the display, even if a password has been set up for the Reset option. See “Resetting Min/Max, Demand, and Energy Values” on page 36 for more information.	N
Lock Pk Dmd Reset	Y or N	Lock the reset of peak demand. If set to Y (yes), the Demand option on the Reset menu will be locked so that the value cannot be reset from the display, even if a password has been set up for the Reset option. See “Resetting Min/Max, Demand, and Energy Values” on page 36 for more information.	N
Lock M/M Reset	Y or N	Lock the reset of the min/max values. If set to Y (yes), the Min/Max option on the Reset menu will be locked so that the value cannot be reset from the display, even if a password has been set up for the Reset option. See “Resetting Min/Max, Demand, and Energy Values” on page 36 for more information.	
Lock Meter Init	Y or N	Lock access to Meter Initialization. If set to Y (Yes), the Meter Init option on the Resets menu will be locked so that this function cannot be done from the display, even if a password has been set up for the Setup/Meter Init option.	N

RESETTING MIN/MAX, DEMAND, AND ENERGY VALUES

A reset clears the circuit monitor's memory of the last recorded value. For example, you might need to reset monthly peak demand power. From the Reset menu, shown in Figure 3–8, you can reset the following values:

- Energy—accumulated energy and conditional energy
- Demand—peak power demand and peak current demand
- Min/Max—minimum and maximum values for all real-time readings

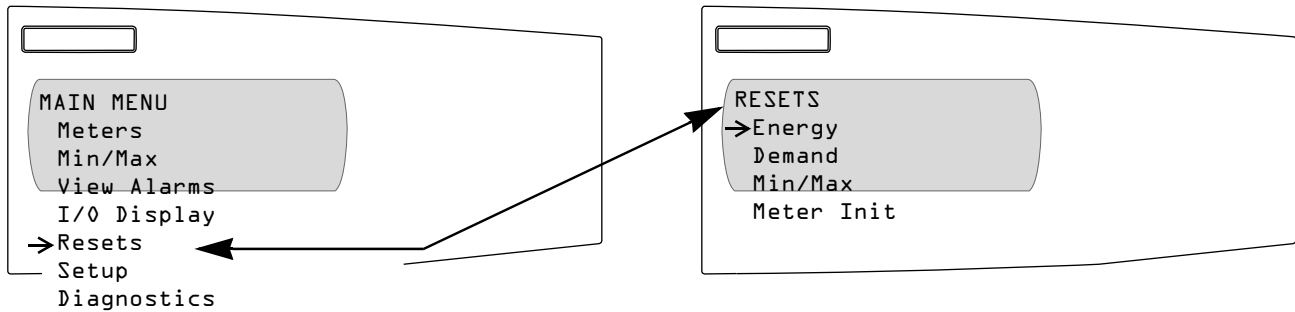

Figure 3–8: Performing resets from the Reset menu

A password is required to reset any of the options on the Reset menu. The default password is 0. See “Setting Up Passwords” on page 26 for more information about passwords.

You can perform resets from the circuit monitor as described in this section or if you are using SMS, you can set up a task to perform the reset automatically at a specified time. See the SMS online help for instructions.

NOTE: To stop users from using the display to reset energy, peak demand, and min/max values, see “Advanced Meter Setup” on page 33 for instructions on using the reset locking feature.

To perform resets, follow these steps:

1. From the Main Menu, select Resets.
The Resets menu displays.

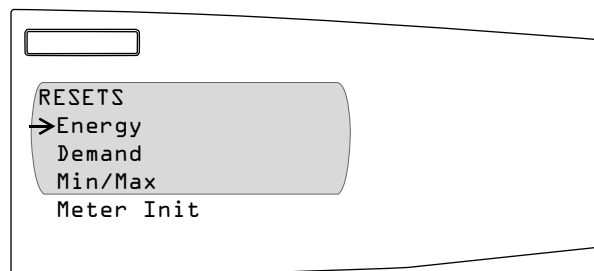

2. Use the arrow buttons to scroll through the menu options on the Resets menu. To select a menu option, press the enter button.
Depending on the option you selected, the screen for that value displays.

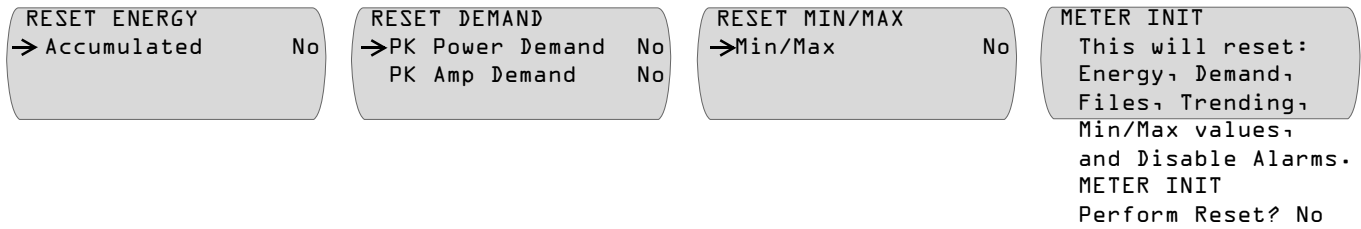

3. Select the option you would like to reset and change No to Yes by pressing the arrow button.
4. Press Enter to move to the next option or press the menu button to reset the value.

VIEWING METERED DATA

The Meters menu and the Min/Max menu, shown in Figure 3–9, are view-only menus where you can view metered data in real time.

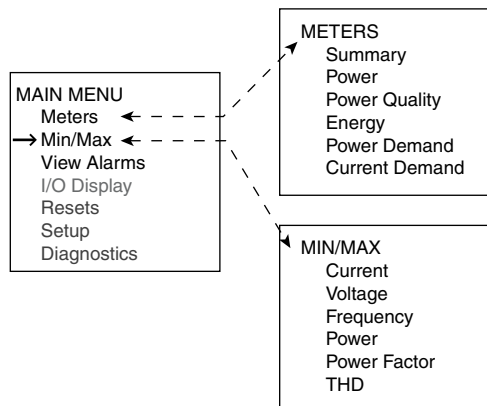

Figure 3–9: Viewing metered data on the Meters and Min/Max menus

Use the arrow buttons to scroll through the menu options on the Meters menu. To select a menu option, press the enter button. To select another option, press the menu button.

Viewing Metered Data from the Meters Menu

From the Meters menu you can view the following information.

- **Summary**—lets you quickly move through and view the following:
 - Summary total of volts, amperes, and kW.
 - Amperes and volts for all three phases, neutral and ground, line to line, line to neutral.
 - Power kW, kVAR, and kVA (real, reactive, and apparent power) 3-phase totals.
 - Power factor (true and displacement) 3-phase totals.

- Total energy kWh, kVARh, and kVAh 3-phase totals (real, reactive, and apparent energy).
- Frequency in hertz.
- **Power**—is available only if the circuit monitor is configured for 4-wire system; it will not appear for 3-wire systems. If you are using a 4-wire system, you can view the leading and lagging values for true and displacement power factor. Also this option lets you view power per-phase kW, kVAR, and kVA (real, reactive, and apparent power).
- **Power Quality**—shows the following values per phase:
 - THD voltage line to neutral and line to line.
 - THD amperes
 - K-factor
 - Fundamental volts and phase angle
 - Fundamental amperes and phase angle
- **Energy**—shows accumulated and incremental readings for real and reactive energy into and out of the load, and the real, reactive, and apparent total of all three phases.
- **Power Demand**—displays total and peak power demand kW, kVAR, and kVA (real, reactive, and apparent power) for the last completed demand interval. It also shows the peak power demand kW, kVAR, and kVA with date, time, and coincident power factor (leading and lagging) associated with that peak.
- **Current Demand**—shows total and peak demand current for all three phases, neutral, and ground. It also shows the date and time of the peak demand current.

Viewing Minimum and Maximum Values from the Min/Max Menu

From the Min/Max menu you can view the minimum and maximum values recorded by the circuit monitor, and the date and time when that min or max value occurred. These values that can be view are:

- Current
- Voltage
- Frequency
- Power
- Power Factor
- THD

To use the Min/Max menu, follow these steps:

1. Use the arrow buttons to scroll through the menu options on the Min/Max menu.

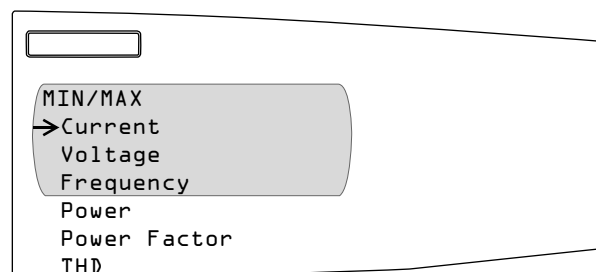

2. To select a menu option, press the enter button.

The screen for that value displays. Press the arrow buttons to scroll through the min/max quantities.

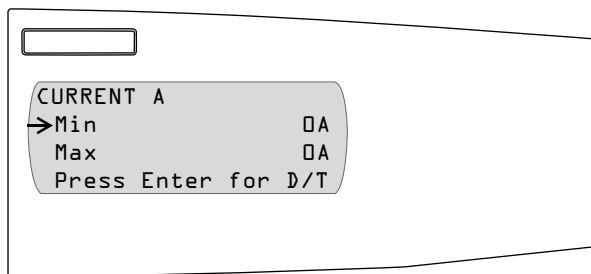

3. To view the date and time when the minimum and maximum value was reached, press the enter button. Press the arrow buttons to scroll through the dates and times.

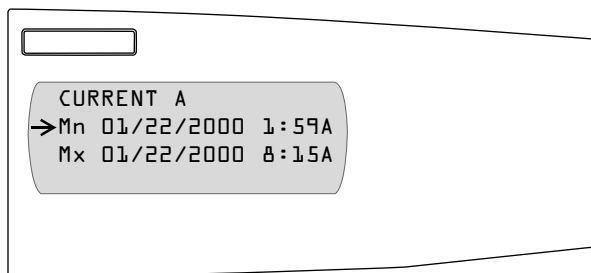

4. Press the enter button to return to the Min/Max values
5. Press the menu button to return to the Min/Max menu.

VIEWING ALARMS

The Alarms menu shown in Figure 3–10, lets you view active and high priority alarms.

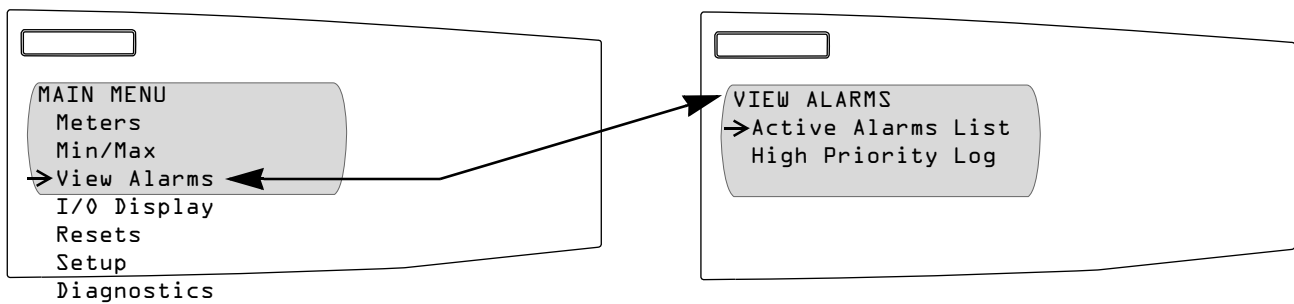

Figure 3–10: View Alarms menu

When an alarm is first set up, an alarm priority is selected. Four alarm levels are available:

- **High priority**—if high priority alarm occurs, the display informs you in two ways:
 - The LED on the display flashes while the alarm is active and until you acknowledge the alarm
 - A message displays whether the alarm is active or unacknowledged.
- **Medium priority**—if medium priority alarm occurs, the LED flashes and a message displays only while the alarm is active. Once the alarm becomes inactive, the LED and message stop.
- **Low priority**—if low priority alarm occurs, the LED on the display flashes only while the alarm is active. No alarm message is displayed.
- **No priority**—if an alarm is setup with no priority, no visible representation will appear on the display.

If multiple alarms with different priorities are active at the same time, the display shows the alarm message for the last alarm.

Each time an alarm occurs, the circuit monitor does the following:

- Puts the alarm in the list of active alarms. See “Viewing Active Alarms” on page 41 for more about active alarms.
- Performs any assigned action. The action could be one of the following:
 - Operate one or more relays (you can view the status from the display)
 - Force data log entries into the user-defined data log files (1–14 data logs can be viewed from SMS)
 - Perform a waveform capture (can be viewed from SMS)
- Records the occurrence of high, medium, and low priority events in the circuit monitor’s alarm Log (can be viewed using SMS).

Also, the display LED and alarm messages will operate according to the priority selected when an alarm occurs.

Viewing Active Alarms

The Active Alarms List displays currently active alarms, regardless of their priority. You can view all active alarms from the Main Menu by selecting View Alarms > Active Alarms List. The Active Alarm screen displays. Use the arrow buttons to scroll through the alarms that are active.

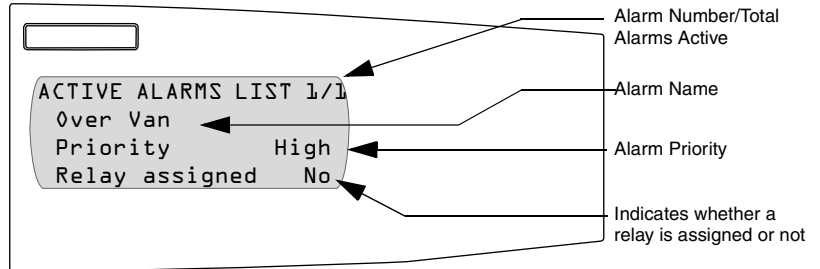

View and Acknowledging High Priority Alarms

To view high priority alarms, from the Main Menu select View Alarms > High Priority Log. The High Priority Log screen displays. Use the arrow buttons to scroll through the alarms.

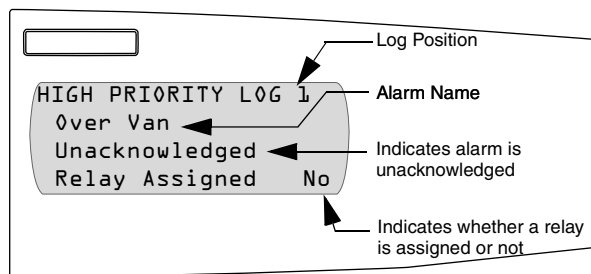

The High Priority Alarms screen displays the ten most recent, high-priority alarms. When you acknowledge the high priority alarms, all digital outputs (relays) that are configured for latched mode will be released. To acknowledge all high priority alarms follow these steps:

1. After viewing the alarms, press the menu button to exit.
The display asks you whether you would like to acknowledge the alarm.

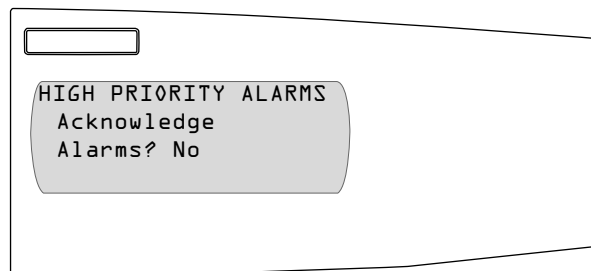

2. To acknowledge the alarms, press the arrow button to change No to Yes. Then, press the enter button.
3. Press the menu button to exit.

NOTE: You have acknowledged the alarms, but the LED will continue to flash as long as any high priority alarm is active.

VIEWING I/O STATUS

The I/O Display menu shows the ON or OFF status of the digital inputs or outputs. To view the status of inputs and outputs:

1. From the Main Menu, select I/O Display.

The I/O Display screen displays.

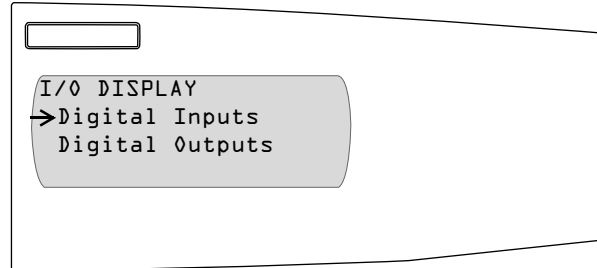

2. Select the input or output on which you'd like to view the status. In this example, we selected Digital Outputs to display the status of the KYZ output.

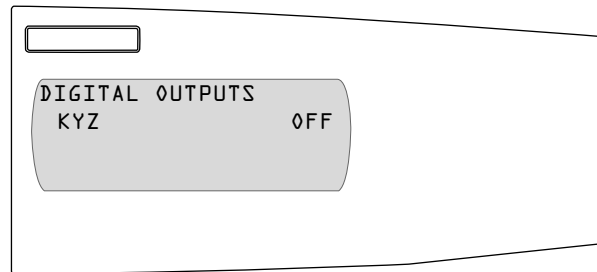

3. Press the menu button to exit.

READING AND WRITING REGISTERS

You can access the read and write register menu option on the circuit monitor's display by selecting from the Main Menu > Diagnostics > Read/Write Regs as shown in Figure 3–11. This option lets you read and write circuit monitor registers from the display. This capability is most useful to users who 1) need to set up an advanced feature which is beyond the circuit monitor's normal front panel setup mode, and 2) do not have access to SMS to set up the feature.

For example, the default operating mode for a circuit monitor relay output is *normal*. To change a relay's operating mode from normal to another mode (for example, latched mode), use either SMS or the Read/Write Regs option of the Diagnostics menu.

NOTE: Use this feature with caution. Writing an incorrect value, or writing to the wrong register could affect the intended operation of the circuit monitor or its accessories.

To read or write registers, follow these steps:

1. From the Main Menu, select Diagnostics.
The Diagnostics menu displays.

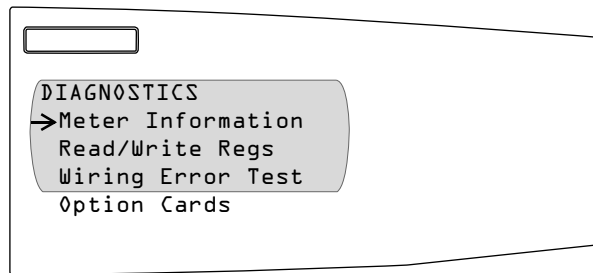

2. Select Read/Write Regs.
The password prompt displays.
3. Select your password. The default password is 0.
The Read/Write Registers screen displays. Table 3–10 describes the options on this screen.

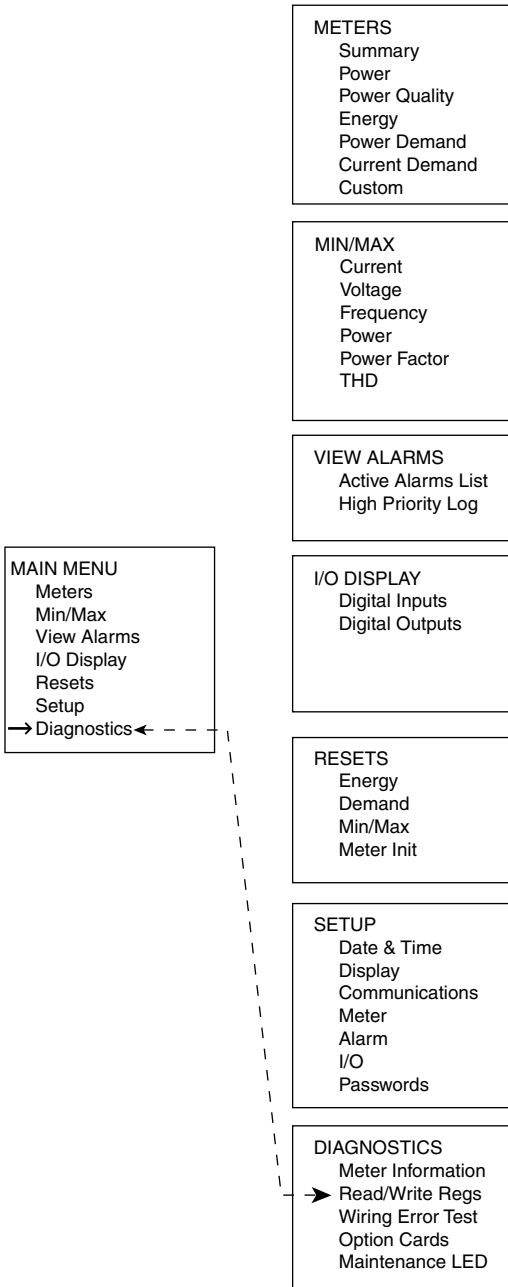
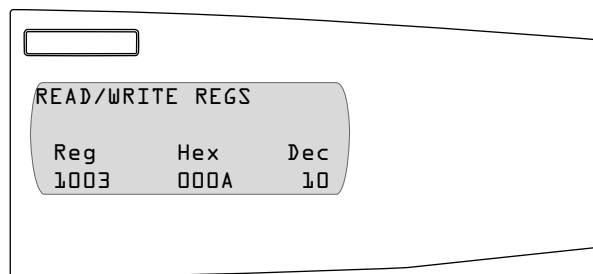

Figure 3–11: Diagnostics Menu accessed from the Main Menu

Table 3–10: Read/Write Register Options

Option	Available Values
Reg	List the register numbers.
Hex	List the hexadecimal value of that register.
Dec	List the decimal value of that register.

If you are viewing a metered value, such as voltage, the circuit monitor updates the displayed value as the register contents change. Note that scale factors are not taken into account automatically when viewing register contents.

4. To scroll through the register numbers, use the arrow buttons.
5. To change the value in the register, press the enter button.
The Hex and Dec values begin to blink. Use the arrow buttons to scroll through the numeric values available.

NOTE: Some circuit monitor registers are **read/write**, some are **read only**. You can write to read/write registers only.

6. When you are finished making changes to that register, press the enter button to continue to the next register or press the menu button to save the changes.

PERFORMING A WIRING ERROR TEST

The circuit monitor has the ability to perform a wiring diagnostic self-check when you select the Diagnostic > Wiring Error Test from the Main Menu as shown in Figure 3–12.

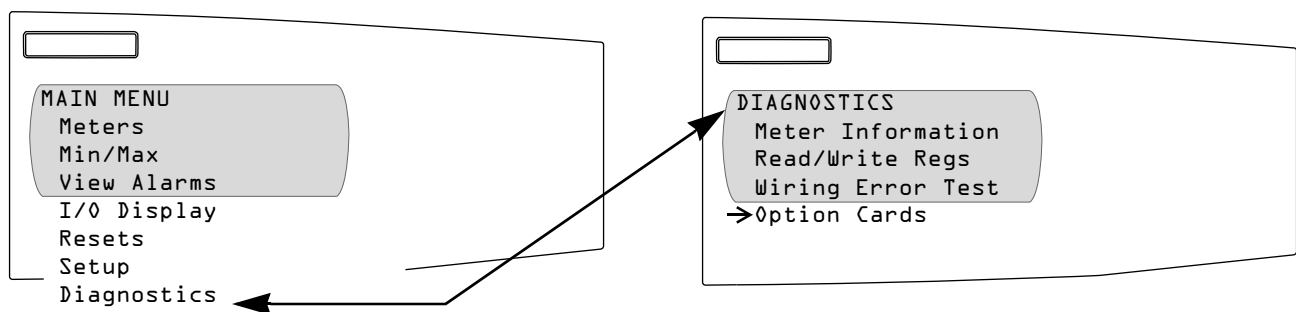

Figure 3–12: Wiring Error Test option on the Diagnostics menu.

The circuit monitor can diagnose possible wiring errors when you initiate the wiring test on the Diagnostics menu. Running the test is not required, but may help you to pinpoint a potentially miswired connection. Before running the wiring test, you must first wire the circuit monitor and perform the minimum set up of the circuit monitor, which includes setting up these parameters:

- CT primary and secondary
- PT primary and secondary
- System type
- Frequency

After you have wired and completed the minimum set up, run the wiring test to verify proper wiring of your circuit monitor. The wiring test assumes that the following is true about your system:

- Voltage connection V_{an} (4-wire) or V_{ab} (3-wire) is correct. This connection must be properly wired for the wiring check program to work.
- 3-phase system. The system must be a 3-phase system. You cannot perform a wiring check on a single-phase system.
- System type. The wiring check can be performed only on the six possible system types: 3Ø3W2CT, 3Ø3W3CT, 3Ø4W3CT, 3Ø4W4CT, 3Ø4W3CT2PT, and 3Ø4W4CT2PT (see Table 5-2 in the installation manual for a description of system types).
- Expected displacement power factor is between .60 lagging and .99 leading.
- The load must be at least 1% of the CT Primary setting.

This wiring error program is based on the assumptions above and based on a typical wiring system, results may vary depending on your system and some errors may not apply to your system. When the wiring test is run, the program performs the following checks in this order:

1. Verifies that the system type is one of those listed above.
2. Verifies that the frequency is within $\pm 5\%$ of the frequency that you selected in circuit monitor set up.
3. Verifies that the voltage phase angles are 120° apart. If the voltage connections are correct, the phase angles will be 120° apart. If the voltage connections are correct, the test continues.
4. Verifies that the measured phase rotation is the same as the phase rotation set up in the circuit monitor.
5. Verifies the magnitude of the currents to see if there is enough load on each phase input to perform the check.
6. Indicates if the 3-phase real power (kW) total is negative, which could indicate a wiring error.
7. Compares each current angle to its respective voltage.

Running the Diagnostics Wiring Error Test

When the circuit monitor detects a possible error, you can find and correct the problem and then run the check again. Repeat the procedure until no error messages are displayed. To perform a wiring diagnostic test, follow these steps:

1. From the Main Menu, select Diagnostics.
The Diagnostics menu displays.

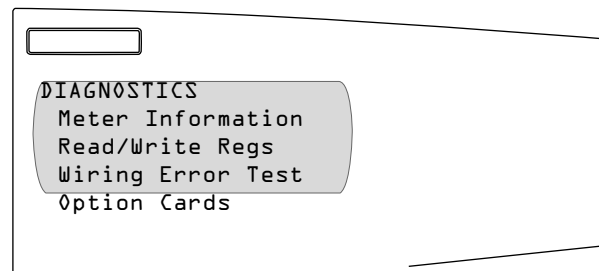

2. Select Wiring Error Test from the menu.
The circuit monitor asks if the wiring matches the test assumptions.

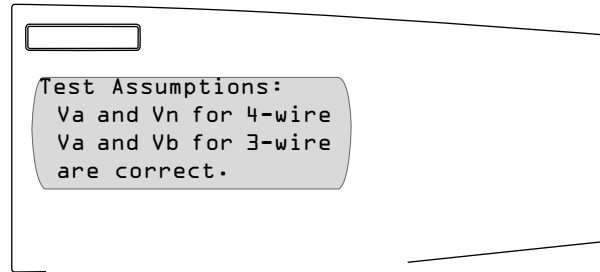

3. Press the down arrow button.
The circuit monitor asks if the expected displacement power factor is between 0.60 lagging and 0.99 leading.

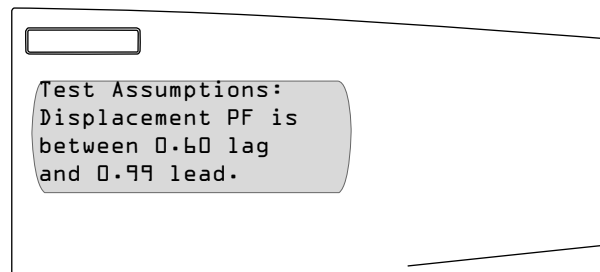

4. Press the down arrow button, again.
The circuit monitor asks if you'd like to perform a wiring check.

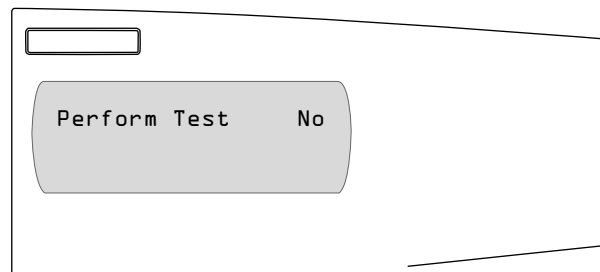

5. Select "Yes" to perform the test by pressing the up arrow button and then pressing the enter button.
The circuit monitor performs the wiring test.
If it doesn't find any errors, the circuit monitor displays "Wire test complete. No errors found!". If it finds possible errors, it displays "Error detected. See following screens for details."
6. Press the arrow buttons to scroll through the wiring error messages.
Table 3-11 on page 47 explains the possible wiring error messages.
7. Turn off all power supplying the circuit monitor. Verify that the power is off using a properly rated voltage testing device.

⚠ DANGER

HAZARD OF ELECTRIC SHOCK, BURN, OR EXPLOSION

- Turn off all power supplying the circuit monitor and the equipment in which it is installed before working on it.
- Use a properly rated voltage testing device to verify that the power is off.
- Never short the secondary of a PT.
- Never open circuit a CT; use the shorting block to short circuit the leads of the CT before removing the connection from the circuit monitor.

Failure to follow this instruction will result in death or serious injury.

8. Correct the wiring errors.
9. Repeat these steps until all errors are corrected.

Table 3–11: Wiring Error Messages

Message	Description
Invalid system type	The circuit monitor is set up for a system type that the wiring test does not support.
Frequency out of range	Actual frequency of the system is not the same as the selected frequency configured for the circuit monitor.
Voltage not present on all phases	No voltage metered on one or more phases.
Severe voltage unbalance present	Voltage unbalance on any phase greater than 70%.
Not enough load to check wiring	Metered current below deadband on one or more phases.
Suspected error: Check meter configuration for direct connection	Set up for voltage input should be "No PT."
Suspected error: Reverse polarity on all current inputs	Check polarities. Polarities on all CTs could be reversed.
Phase rotation does not match meter setup	Metered phase rotation is different than phase rotation selected in the circuit monitor set up.
Negative kW, check CT & VT polarities	Metered kW is negative, which could indicate swapped polarities on any CT or VT.
No voltage metered on V1–n	No voltage metered on V1–n on 4-wire system only.
No voltage metered on V2–n	No voltage metered on V2–n on 4-wire system only.
No voltage metered on V3–n	No voltage metered on V3–n on 4-wire system only.
No voltage metered on V1–2	No voltage metered on V1–2.
No voltage metered on V2–3	No voltage metered on V2–3.
No voltage metered on V3–1	No voltage metered on V3–1.
V2–n phase angle out of range	V2–n phase angle out of expected range.
V3–n phase angle out of range	V3–n phase angle out of expected range.
V2–3 phase angle out of range	V2–3 phase angle out of expected range.
V3–1 phase angle out of range	V3–1 phase angle out of expected range.
Suspected error: Reverse polarity on V2–n VT	Polarity of V2–n VT could be reversed. Check polarity.
Suspected error: Reverse polarity on V3–n VT	Polarity of V3–n VT could be reversed. Check polarity.
Suspected error: Reverse polarity on V2–3 VT	Polarity of V2–3 VT could be reversed. Check polarity.

Table 3–11: Wiring Error Messages

Message	Description
Suspected error: Polarity on V3–1 VT	Polarity of V3–1 VT could be reversed. Check polarity.
Suspected error: Check V1 input, may be V2 VT	Phase 2 VT may actually be connected to input V1.
Suspected error: Check V2 input, may be V3 VT	Phase 3 VT may actually be connected to input V12
Suspected error: Check V3 input, may be V1 VT	Phase 1 VT may actually be connected to input V3.
Suspected error: Check V1 input, may be V3 VT	Phase 3 VT may actually be connected to input V1.
Suspected error: Check V2 input, may be V1 VT	Phase 1 VT may actually be connected to input V2.
Suspected error: Check V3 input, may be V2 VT	Phase 2 VT may actually be connected to input V3.
I1 load current less than 1% CT	Metered current on I1 less than 1% of CT. Test could not continue.
I2 load current less than 1% CT	Metered current on I2 less than 1% of CT. Test could not continue.
I3 load current less than 1% CT	Metered current on I3 less than 1% of CT. Test could not continue.
I1 phase angle out of range. Cause of error unknown.	I1 phase angle is out of expected range. Cause of error unable to be determined.
I2 phase angle out of range. Cause of error unknown	I2 phase angle is out of expected range. Cause of error unable to be determined.
I3 phase angle out of range. Cause of error unknown.	I3 phase angle is out of expected range. Cause of error unable to be determined.
Suspected error: Reverse polarity on I1 CT.	Polarity of I1 CT could be reversed. Check polarity.
Suspected error: Reverse polarity on I2 CT	Polarity of I2 CT could be reversed. Check polarity.
Suspected error: Reverse polarity on I3 CT	Polarity of I3 CT could be reversed. Check polarity.
Suspected error: Check I1 input, may be I2 CT	Phase 2 CT may actually be connected to input I1 .
Suspected error: Check I2 input, may be I3 CT	Phase 3 CT may actually be connected to input I2.
Suspected error: Check I3 input, may be I1 CT	Phase 1 CT may actually be connected to input I3.
Suspected error: Check I1 input, may be I3 CT	Phase 3 CT may actually be connected to input I1 .
Suspected error: Check I2 input, may be I1 CT	Phase 1 CT may actually be connected to input I2.
Suspected error: Check I3 input, may be I2 CT	Phase 2 CT may actually be connected to input I3.
Suspected error: Check I1 input, may be I2 CT with reverse polarity	Phase 2 CT may actually be connected to input I1 , and the CT polarity may also be reversed.
Suspected error: Check I2 input, may be I3 CT with reverse polarity	Phase 3 CT may actually be connected to input I21, and the CT polarity may also be reversed.
Suspected error: Check I3 input, may be I1 CT with reverse polarity	Phase 1 CT may actually be connected to input I3, and the CT polarity may also be reversed.
Suspected error: Check I1 input, may be I3 CT with reverse polarity	Phase 3 CT may actually be connected to input I1 , and the CT polarity may also be reversed.
Suspected error: Check I2 input, may be I1 CT with reverse polarity	Phase 1 CT may actually be connected to input I2, and the CT polarity may also be reversed.
Suspected error. Check I3 input, may be I2 CT with reverse polarity	Phase 2 CT may actually be connected to input I3, and the CT polarity may also be reversed.

CHAPTER 4—METERING CAPABILITIES

This chapter details the types of meter readings you can obtain from the circuit monitor.

CHAPTER CONTENTS

CHAPTER CONTENTS	49
REAL-TIME READINGS	50
MIN/MAX VALUES FOR REAL-TIME READINGS	50
Power Factor Min/Max Conventions	51
VAR SIGN CONVENTIONS	53
DEMAND READINGS	54
Demand Power Calculation Methods	55
Block Interval Demand	55
Synchronized Demand	57
Demand Current	57
Demand Voltage	57
Thermal Demand	58
Predicted Demand	58
Peak Demand	59
Generic Demand	59
Input Pulse Demand Metering	60
ENERGY READINGS	61
POWER ANALYSIS VALUES	64

REAL-TIME READINGS

The circuit monitor measures currents and voltages and reports in real time the rms values for all three phases, neutral, and ground current. In addition, the circuit monitor calculates power factor, real power, reactive power, and more.

Table 4–1 lists some of the real-time readings that are updated every second along with their reportable ranges. When you are viewing real-time readings from the remote display or SMS, the circuit monitor is displaying 100-ms readings.

Table 4–1: One-Second, Real-Time Readings Samples

Real-Time Readings	Reportable Range
Current	
Per-Phase	0 to 32,767 A
Neutral ^①	0 to 32,767 A
Ground ^①	0 to 32,767 A
3-Phase Average	0 to 32,767 A
Apparent rms	0 to 32,767 A
% Unbalance	0 to ±100.0%
Voltage	
Line-to-Line, Per-Phase	0 to 1,200 kV
Line-to-Line, 3-Phase Average	0 to 1,200 kV
Line-to-Neutral, Per-Phase ^①	0 to 1,200 kV
Neutral to Ground ^①	0 to 1,200 kV
Line-to-Neutral, 3-Phase Average	0 to 1,200 kV
% Unbalance ^①	0 to 100.0%
Real Power	
Per-Phase ^①	0 to ± 3,276.70 MW
3-Phase Total	0 to ± 3,276.70 MW
Reactive Power	
Per-Phase ^①	0 to ± 3,276.70 MVAR
3-Phase Total	0 to ± 3,276.70 MVAR
Apparent Power	
Per-Phase ^①	0 to ± 3,276.70 MVA
3-Phase Total	0 to ± 3,276.70 MVA
Power Factor (True)	
Per-Phase ^①	–0.010 to 1.000 to +0.010
3-Phase Total	–0.010 to 1.000 to +0.010
Power Factor (Displacement)	
Per-Phase ^①	–0.010 to 1.000 to +0.010
3-Phase Total	–0.010 to 1.000 to +0.010
Frequency	
45–65 Hz	23.00 to 67.00 Hz
350–450 Hz	350.00 to 450.00 Hz
Temperature (Internal Ambient)	
	–100.00°C to +100.00°C

^① Wye systems only.

MIN/MAX VALUES FOR REAL-TIME READINGS

When any one-second real-time reading reaches its highest or lowest value, the circuit monitor saves the value in its nonvolatile memory. These values are called the minimum and maximum (min/max) values. Two logs are associated with min/max values. The Min/Max Log stores the minimum and maximum values since the last reset of the min/max values. The other log, the Interval Min/Max/Average Log, determines min/max values over a

specified interval and records the minimum, maximum, and average values for pre-defined quantities over that specified interval. For example, the circuit monitor could record the min, max, and average every 1440 minutes (total minutes in a day) to record the daily value of quantities such as kW demand. See **Chapter 7—Logging** on page 93 for more about the Min/Max/Average log.

From the circuit monitor display you can:

- View all min/max values since the last reset and view their associated dates and times. See “Viewing Minimum and Maximum Values from the Min/Max Menu” on page 38 for instructions.
- Reset min/max values. See “Resetting Min/Max, Demand, and Energy Values” on page 36 for reset instructions.

Using SMS you can also upload both onboard logs—and their associated dates and times—from the circuit monitor and save them to disk. For instructions on working with logs using SMS, refer to the SMS online help file included with the software.

Power Factor Min/Max Conventions

All running min/max values, except for power factor, are arithmetic minimum and maximum values. For example, the minimum phase A–B voltage is the lowest value in the range 0 to 1200 kV that has occurred since the min/max values were last reset. In contrast, because the power factor’s midpoint is unity (equal to one), the power factor min/max values are not true arithmetic minimums and maximums. Instead, the minimum value represents the measurement closest to -0 on a continuous scale for all real-time readings -0 to 1.00 to $+0$. The maximum value is the measurement closest to $+0$ on the same scale.

Figure 4–1 below shows the min/max values in a typical environment in which a positive power flow is assumed. In the figure, the minimum power factor is $-.7$ (lagging) and the maximum is $.8$ (leading). Note that the minimum power factor need not be lagging, and the maximum power factor need not be leading. For example, if the power factor values ranged from $-.75$ to $-.95$, then the minimum power factor would be $-.75$ (lagging) and the maximum power factor would be $-.95$ (lagging). Both would be negative. Likewise, if the power factor ranged from $+.9$ to $+.95$, the minimum would be $+.95$ (leading) and the maximum would be $+.90$ (leading). Both would be positive in this case.

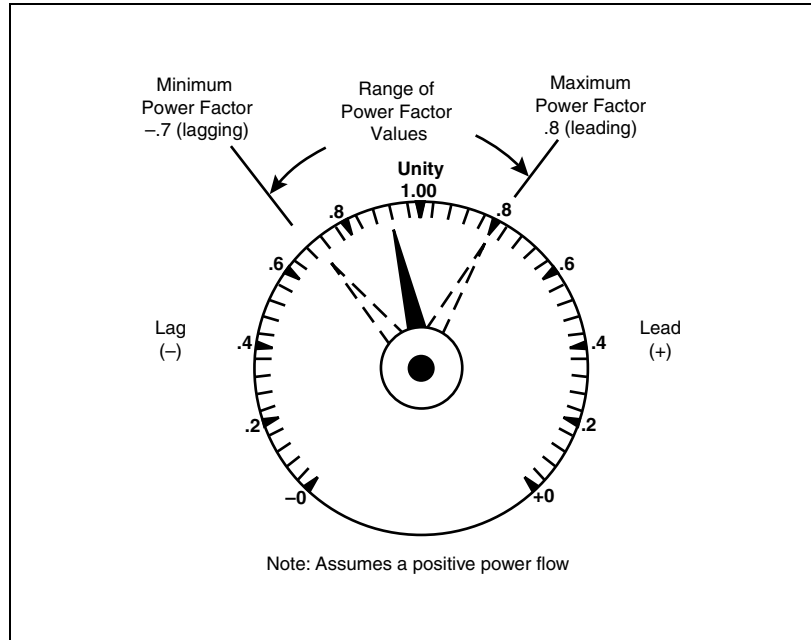

Figure 4-1: Power factor min/max example

An alternate power factor storage method is also available for use with analog outputs and trending. See the footnotes in **Appendix A—Abbreviated Register Listing** on page 121 for the applicable registers.

VAR SIGN CONVENTIONS

The circuit monitor can be set to one of two VAR sign conventions, the standard IEEE or the ALT (CM1). The Series 3000 Circuit Monitor defaults to the IEEE VAR sign convention. Figure 4–2 illustrates the VAR sign convention defined by IEEE and the default used by previous model circuit monitors (CM1). For instructions on changing the VAR sign convention, refer to “Advanced Meter Setup” on page 33.

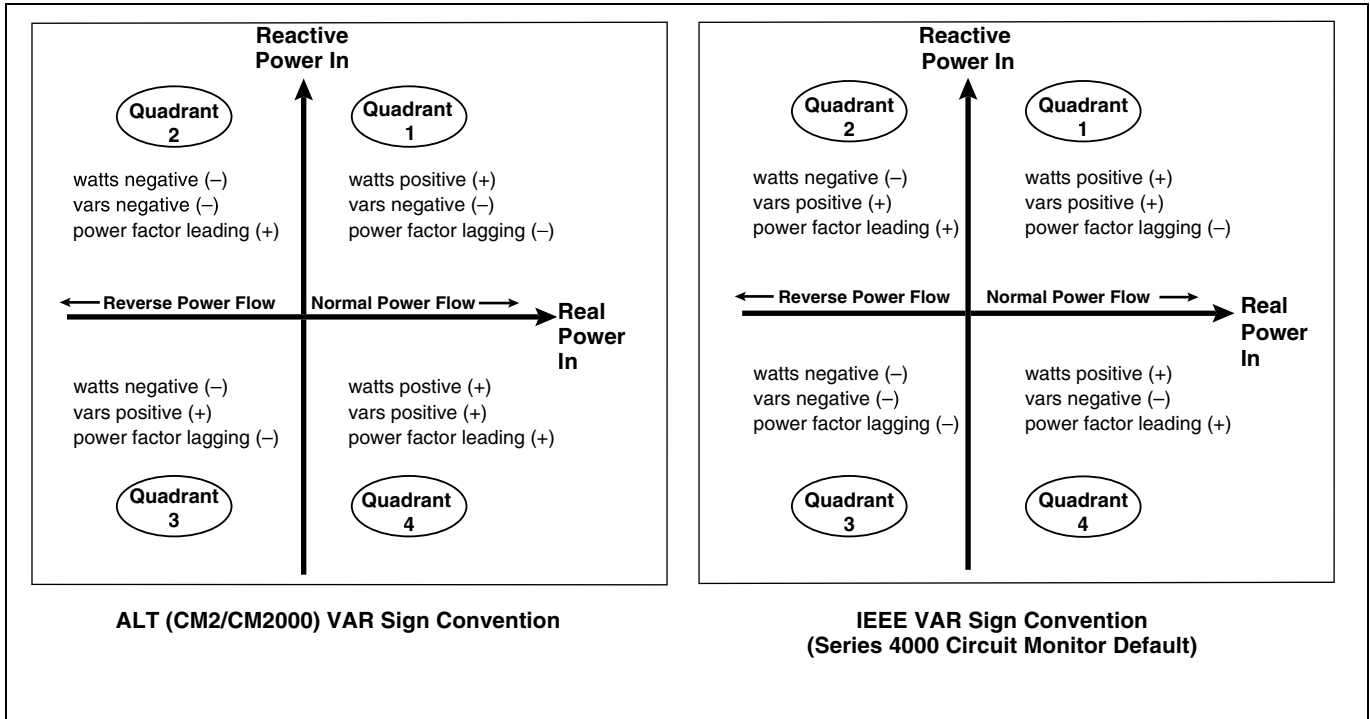

Figure 4–2: Reactive Power—VAR sign convention

DEMAND READINGS

The circuit monitor provides a variety of demand readings, including coincident readings and predicted demands. Table 4–2 lists the available demand readings and their reportable ranges.

Table 4–2: Demand Readings

Demand Readings	Reportable Range
Demand Current, Per-Phase, 3Ø Average, Neutral	
Last Complete Interval	0 to 32,767 A
Peak	0 to 32,767 A
Demand Voltage, L–N, L–L, Per-phase, Average,	
Last Complete Interval	0 to 1200 kV
Minimum	0 to 1200 kV
Peak	0 to 1200 kV
Average Power Factor (True), 3Ø Total	
Last Complete Interval	–0.010 to 1.000 to +0.010
Coincident with kW Peak	–0.010 to 1.000 to +0.010
Coincident with kVAR Peak	–0.010 to 1.000 to +0.010
Coincident with kVA Peak	–0.010 to 1.000 to +0.010
Demand Real Power, 3Ø Total	
Last Complete Interval	0 to ± 3276.70 MW
Predicted	0 to ± 3276.70 MW
Peak	0 to ± 3276.70 MW
Coincident kVA Demand	0 to ± 3276.70 MVA
Coincident kVAR Demand	0 to ± 3276.70 MVAR
Demand Reactive Power, 3Ø Total	
Last Complete Interval	0 to ± 3276.70 MVAR
Predicted	0 to ± 3276.70 MVAR
Peak	0 to ± 3276.70 MVAR
Coincident kVA Demand	0 to ± 3276.70 MVA
Coincident kW Demand	0 to ± 3276.70 MW
Demand Apparent Power, 3Ø Total	
Last Complete Interval	0 to ± 3276.70 MVA
Predicted	0 to ± 3276.70 MVA
Peak	0 to ± 3276.70 MVA
Coincident kW Demand	0 to ± 3276.70 MW
Coincident kVAR Demand	0 to ± 3276.70 MVAR

Demand Power Calculation Methods

Demand power is the energy accumulated during a specified period divided by the length of that period. How the circuit monitor performs this calculation depends on the method you select. To be compatible with electric utility billing practices, the circuit monitor provides the following types of demand power calculations:

- Block Interval Demand
- Synchronized Demand

The default demand calculation is set to sliding block with a 15 minute interval. You can set up any of the demand power calculation methods from the display or from SMS. For instructions on how to setup the demand calculation from the display, see “Setting Up the Metering Functions of the Circuit Monitor” on page 16. See the SMS online help to perform the set up using the software.

Block Interval Demand

In the block interval demand method, you select a “block” of time that the circuit monitor uses for the demand calculation. You choose how the circuit monitor handles that block of time (interval). Three different modes are possible:

- **Sliding Block.** In the sliding block interval, you select an interval from 1 to 60 minutes (in 1-minute increments). If the interval is between 1 and 15 minutes, the demand calculation *updates every 15 seconds*. If the interval is between 16 and 60 minutes, the demand calculation *updates every 60 seconds*. The circuit monitor displays the demand value for the last completed interval.
- **Fixed Block.** In the fixed block interval, you select an interval from 1 to 60 minutes (in 1-minute increments). The circuit monitor calculates and updates the demand at the end of each interval.
- **Rolling Block.** In the rolling block interval, you select an interval and a subinterval. The subinterval must divide evenly into the interval. For example, you might set three 5-minute subintervals for a 15-minute interval. Demand is *updated at each subinterval*. The circuit monitor displays the demand value for the last completed interval.

Figure 4–3 below illustrates the three ways to calculate demand power using the block method. For illustration purposes, the interval is set to 15 minutes.

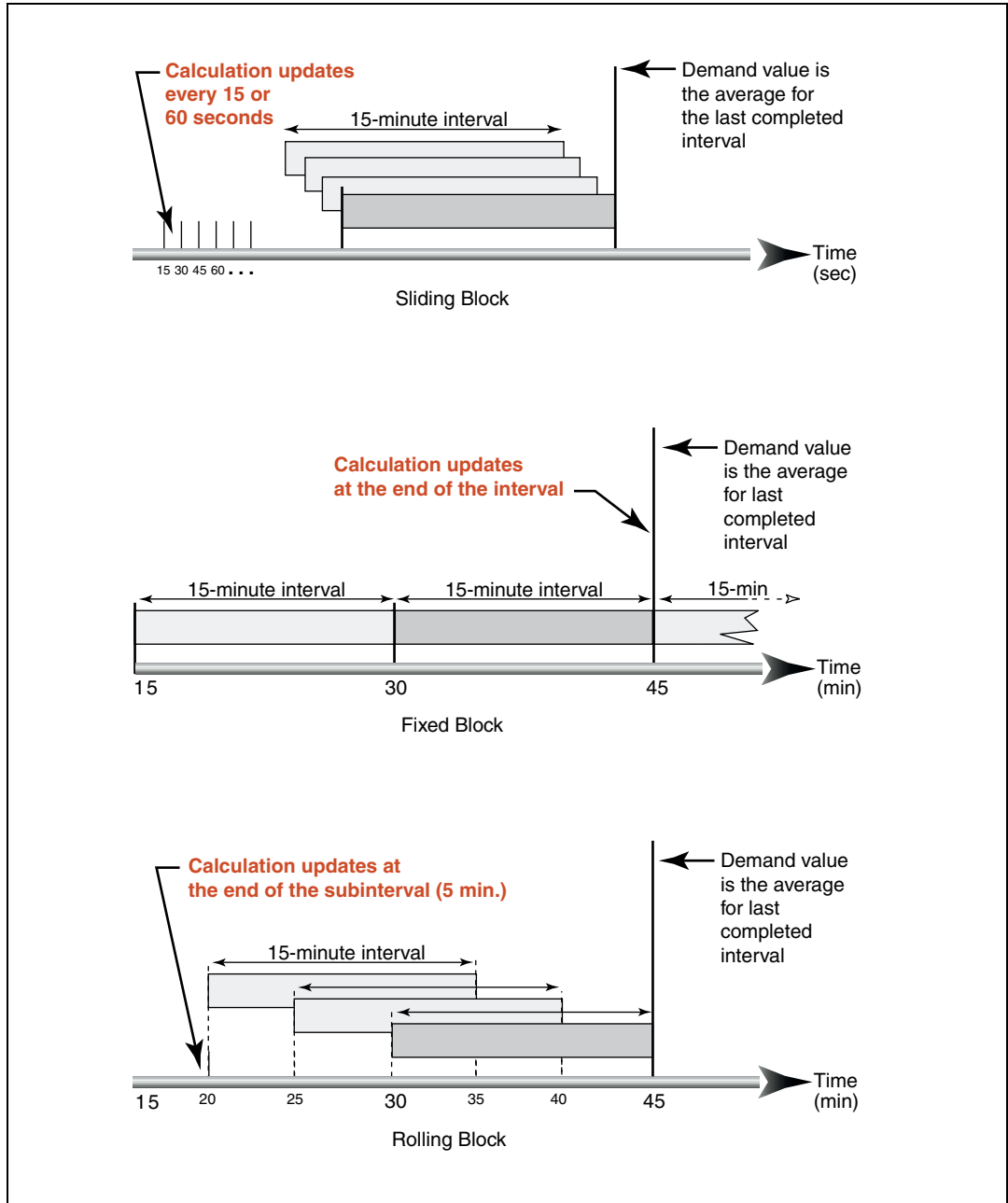

Figure 4-3: Block Interval Demand Examples

Synchronized Demand

The demand calculations can be synchronized by accepting an external pulse input, a command sent over communications, or by synchronizing to the internal real-time clock.

- **Input Synchronized Demand.** You can set up the circuit monitor to accept an input such as a demand synch pulse from an external source. The circuit monitor then uses the same time interval as the other meter for each demand calculation. You can use any digital input installed on the meter to receive the synch pulse. When setting up this type of demand, you select whether it will be input-synchronized block or input-synchronized rolling block demand. The rolling block demand requires that you choose a subinterval.
- **Command Synchronized Demand.** Using command synchronized demand, you can synchronize the demand intervals of multiple meters on a communications network. For example, if a PLC input is monitoring a pulse at the end of a demand interval on a utility revenue meter, you could program the PLC to issue a command to multiple meters whenever the utility meter starts a new demand interval. Each time the command is issued, the demand readings of each meter are calculated for the same interval. When setting up this type of demand, you select whether it will be command-synchronized block or command-synchronized rolling block demand. The rolling block demand requires that you choose a subinterval. See **Appendix B—Using the Command Interface** on page 199 for more information.
- **Clock Synchronized Demand.** You can synchronize the demand interval to the internal real-time clock in the circuit monitor. This enables you to synchronize the demand to a particular time, typically on the hour. The default time is 12:00 am. If you select another time of day when the demand intervals are to be synchronized, the time must be in minutes from midnight. For example, to synchronize at 8:00 am, select 480 minutes. When setting up this type of demand, you select whether it will be clock-synchronized block or clock-synchronized rolling block demand. The rolling block demand requires that you choose a subinterval.

Demand Current

The circuit monitor calculates demand current using the thermal demand method. The default interval is 15 minutes, but you can set the demand current interval between 1 and 60 minutes in 1-minute increments.

Demand Voltage

The circuit monitor calculates demand voltage. The default voltage demand mode is thermal demand with a 15-minute demand interval. You can also set the demand voltage to any of the block interval demand modes described in “Block Interval Demand” on page 55.

Thermal Demand

The thermal demand method calculates the demand based on a thermal response, which mimics thermal demand meters. The demand calculation updates at the end of each interval. You select the demand interval from 1 to 60 minutes (in 1-minute increments). In Figure 4–4 the interval is set to 15 minutes for illustration purposes.

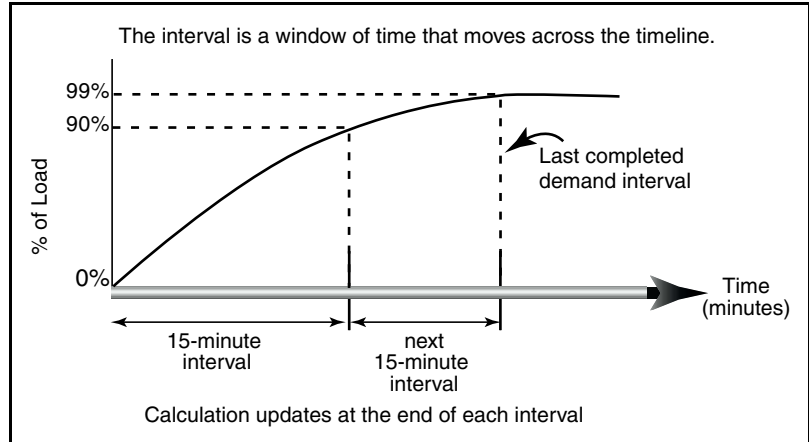

Figure 4–4: Thermal Demand Example

Predicted Demand

The circuit monitor calculates predicted demand for the end of the present interval for kW, kVAR, and kVA demand. This prediction takes into account the energy consumption thus far within the present (partial) interval and the present rate of consumption. The prediction is updated every second.

Figure 4–5 illustrates how a change in load can affect predicted demand for the interval.

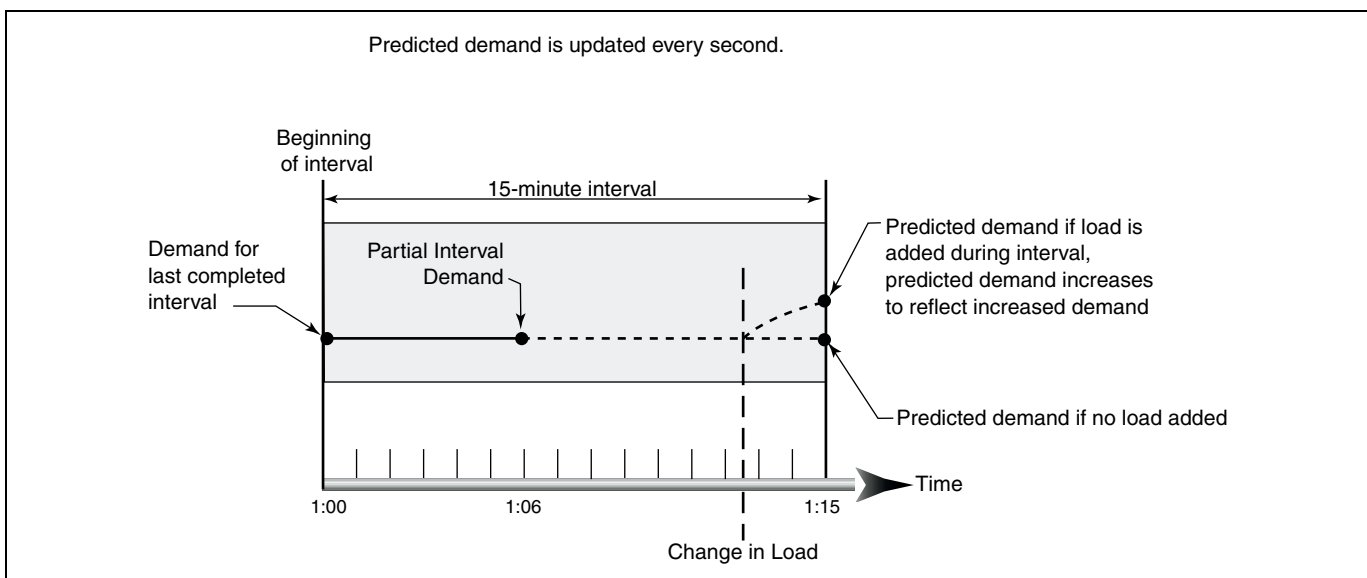

Figure 4–5: Predicted Demand Example

Peak Demand

In nonvolatile memory, the circuit monitor maintains a running maximum for power demand values, called “peak demand.” The peak is the highest average for each of these readings: kWd, kVARD, and kVAD since the last reset. The circuit monitor also stores the date and time when the peak demand occurred. In addition to the peak demand, the circuit monitor also stores the coinciding average 3-phase power factor. The average 3-phase power factor is defined as “demand kW/demand kVA” for the peak demand interval. Table 4–2 on page 54 lists the available peak demand readings from the circuit monitor.

You can reset peak demand values from the circuit monitor display. From the Main Menu, select Resets > Demand. You can also reset the values over the communications link by using SMS. See the SMS online help for instructions.

NOTE: You should reset peak demand after changes to basic meter setup, such as CT ratio or system type.

The circuit monitor also stores the peak demand during the last incremental energy interval. See “Energy Readings” on page 61 for more about incremental energy readings.

Generic Demand

The circuit monitor can perform any of the demand calculation methods, described earlier in this chapter, on up to 20 quantities that you choose. In SMS the quantities are divided into two groups of 10, so you can set up two different demand “profiles.” For each profile, you do the following in SMS:

- **Select the demand calculation method** (thermal, block interval, or synchronized).
- **Select the demand interval** (from 5–60 minutes in 1–minute increments) and select the demand subinterval (if applicable).
- **Select the quantities** on which to perform the demand calculation. You must also select the units and scale factor for each quantity.

Use the Device Setup > Basic Setup tab in SMS to create the generic demand profiles. For each quantity in the demand profile, the circuit monitor stores four values:

- Partial interval demand value
- Last completed demand interval value
- Minimum values (date and time for each is also stored)
- Peak demand value (date and time for each is also stored)

You can reset the minimum and peak values of the quantities in a generic demand profile by using one of two methods:

- Use SMS (see the SMS online help file), or
- Use the command interface.

Command 5115 resets the generic demand profile 1.

Command 5116 resets the generic demand profile 2.

See **Appendix B—Using the Command Interface** on page 199 for more about the command interface.

Input Pulse Demand Metering

The circuit monitor has ten input pulse metering channels. The channels count pulses received from one or more digital inputs assigned to that channel. Each channel requires a consumption pulse weight, consumption scale factor, demand pulse weight, and demand scale factor. The consumption pulse weight is the number of watt-hours or kilowatt-hours per pulse. The consumption scale factor is a factor of 10 multiplier that determines the format of the value. For example, if each incoming pulse represents 125 Wh, and you want consumption data in watt-hours, the consumption pulse weight is 125 and the consumption scale factor is zero. The resulting calculation is 125×10^0 , which equals 125 watt-hours per pulse. If you want the consumption data in kilowatt-hours, the calculation is 125×10^{-3} , which equals 0.125 kilowatt-hours per pulse.

Time must be taken into account for demand data so you begin by calculating demand pulse weight using the following formula:

$$\text{watts} = \frac{\text{watt-hours}}{\text{pulse}} \times \frac{3600 \text{ seconds}}{\text{hour}} \times \frac{\text{pulse}}{\text{second}}$$

If each incoming pulse represents 125 Wh, using the formula above you get 450,000 watts. If you want demand data in watts, the demand pulse weight is 450 and the demand scale factor is three. The calculation is 450×10^3 , which equals 450,000 watts. If you want the demand data in kilowatts, the calculation is 450×10^0 , which equals 450 kilowatts.

The circuit monitor counts each input transition as a pulse. Therefore, for an input transition of OFF-to-ON and ON-to-OFF will be counted as two pulses. For each channel, the circuit monitor maintains the following information:

- Total consumption
- Last completed interval demand—calculated demand for the last completed interval.
- Partial interval demand—demand calculation up to the present point during the interval.
- Peak demand—highest demand value since the last reset of the input pulse demand. The date and time of the peak demand is also saved.
- Minimum demand—lowest demand value since the last reset of the input pulse demand. The date and time of the minimum demand is also saved.

For example, you can use channels to verify utility charges. In Figure 4-6 on page 61, Channel 1 is adding demand from two utility feeders to track total consumption and demand for the building. This information could be viewed in SMS and compared against the utility charges.

To use the channels feature, first set up the digital inputs from the display or from SMS. See “Setting Up I/Os” on page 24 in **Chapter 3—Operation** for instructions. Then using SMS, you must set the I/O operating mode to Normal and set up the channels. The demand method and interval that you select applies to all channels. See the SMS online help for instructions on device set up of the CM4000 Circuit Monitor.

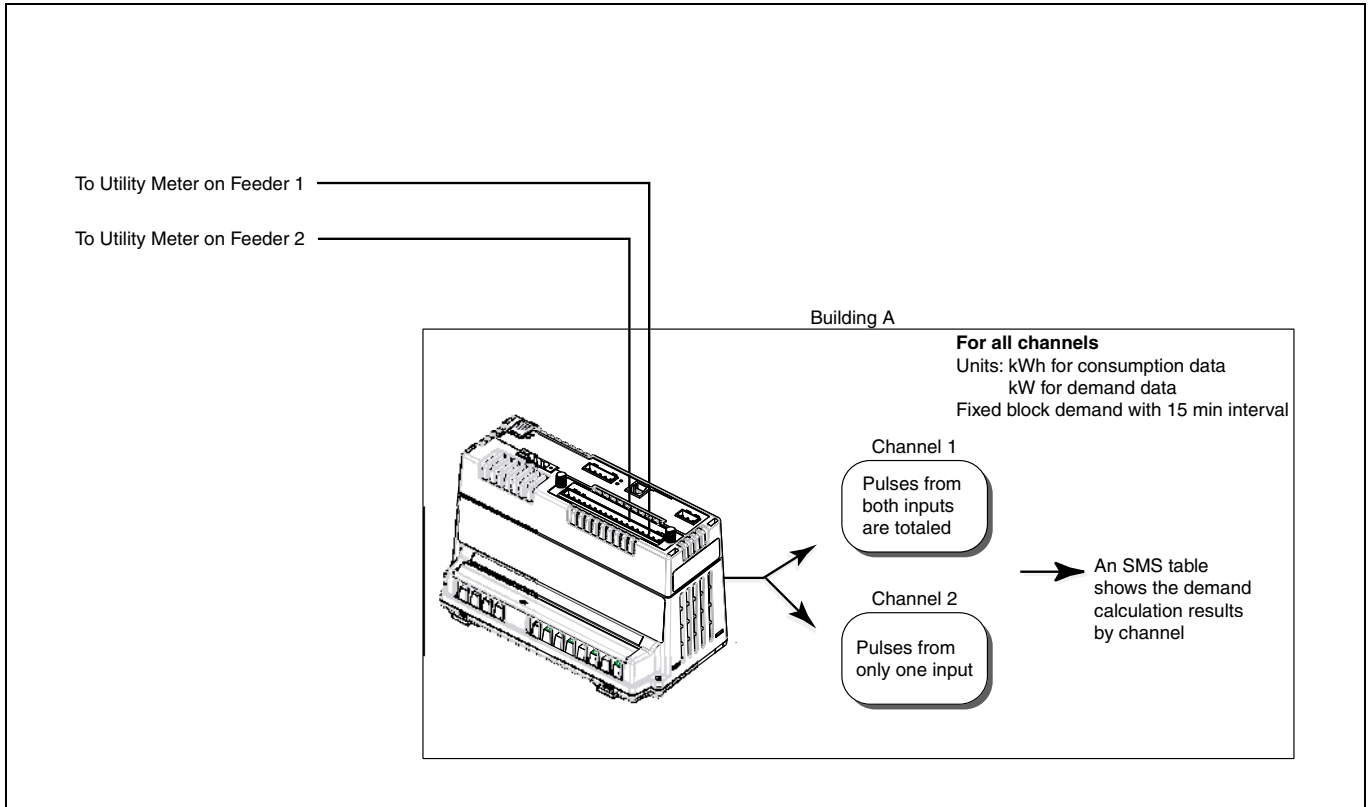

Figure 4–6: Input pulse metering example

ENERGY READINGS

The circuit monitor calculates and stores accumulated energy values for real and reactive energy (kWh and kVARh) both into and out of the load, and also accumulates absolute apparent energy. Table 4–3 lists the energy values the circuit monitor can accumulate.

Table 4–3: Energy Readings

Energy Reading, 3-Phase	Reportable Range	Shown on the Display
Accumulated Energy		
Real (Signed/Absolute)	-9,999,999,999,999,999 to 9,999,999,999,999,999 Wh	0000.000 kWh to 99,999.99 MWh and 0000.000 to 99,999.99 MVARh
Reactive (Signed/Absolute)	-9,999,999,999,999,999 to 9,999,999,999,999,999 VARh	
Real (In)	0 to 9,999,999,999,999,999 Wh	0000.000 kWh to 99,999.99 MWh and 0000.000 to 99,999.99 MVARh
Real (Out)	0 to 9,999,999,999,999,999 Wh	
Reactive (In)	0 to 9,999,999,999,999,999 VARh	
Reactive (Out)	0 to 9,999,999,999,999,999 VARh	
Apparent	0 to 9,999,999,999,999,999 VAh	
Accumulated Energy, Conditional		Not shown on the display. Readings are obtained only through the communications link.
Real (In) ①	0 to 9,999,999,999,999,999 Wh	
Real (Out) ①	0 to 9,999,999,999,999,999 Wh	
Reactive (In) ①	0 to 9,999,999,999,999,999 VARh	
Reactive (Out) ①	0 to 9,999,999,999,999,999 VARh	
Apparent ①	0 to 9,999,999,999,999,999 VAh	

Table 4–3: Energy Readings

Accumulated Energy, Incremental		
Real (In)	0 to 999,999,999,999 Wh	0000.000 kWh to 99,999.99 MWh and 0000.000 to 99,999.99 MVARh
Real (Out)	0 to 999,999,999,999 Wh	
Reactive (In)	0 to 999,999,999,999 VARh	
Reactive (Out)	0 to 999,999,999,999 VARh	
Apparent	0 to 999,999,999,999 VAh	
Reactive Energy		
Quadrant 1 ①	0 to 999,999,999,999 VARh	Not shown on the display. Readings are obtained only through the communications link.
Quadrant 2 ①	0 to 999,999,999,999 VARh	
Quadrant 3 ①	0 to 999,999,999,999 VARh	
Quadrant 4 ①	0 to 999,999,999,999 VARh	

① Values can be displayed on the screen by creating custom quantities and custom displays.

The circuit monitor can accumulate the energy values shown in Table 4–3 in one of two modes: signed or unsigned (absolute). In signed mode, the circuit monitor considers the direction of power flow, allowing the magnitude of accumulated energy to increase and decrease. In unsigned mode, the circuit monitor accumulates energy as a positive value, regardless of the direction of power flow. In other words, the energy value increases, even during reverse power flow. The default accumulation mode is unsigned.

You can view accumulated energy from the display. The resolution of the energy value will automatically change through the range of 000.000 kWh to 000,000 MWh (000.000 to 000,000 MVARh), or it can be fixed.

See **Appendix A—Abbreviated Register Listing** on page 121 for the contents of the registers.

For conditional accumulated energy readings, you can set the real, reactive, and apparent energy accumulation to OFF or ON when a particular condition occurs. You can do this over the communications link using a command, or from a digital input change. For example, you may want to track accumulated energy values during a particular process that is controlled by a PLC. The circuit monitor stores the date and time of the last reset of conditional energy in nonvolatile memory.

Also, the circuit monitor provides an additional energy reading that is only available over the communications link:

- **Four-quadrant reactive accumulated energy readings.** The circuit monitor accumulates reactive energy (kVARh) in four quadrants as shown in Figure 4–7. The registers operate in unsigned (absolute) mode in which the circuit monitor accumulates energy as positive.

NOTE: The reactive accumulated energy is not affected by the VAR sign convention and will remain as shown in the image below.

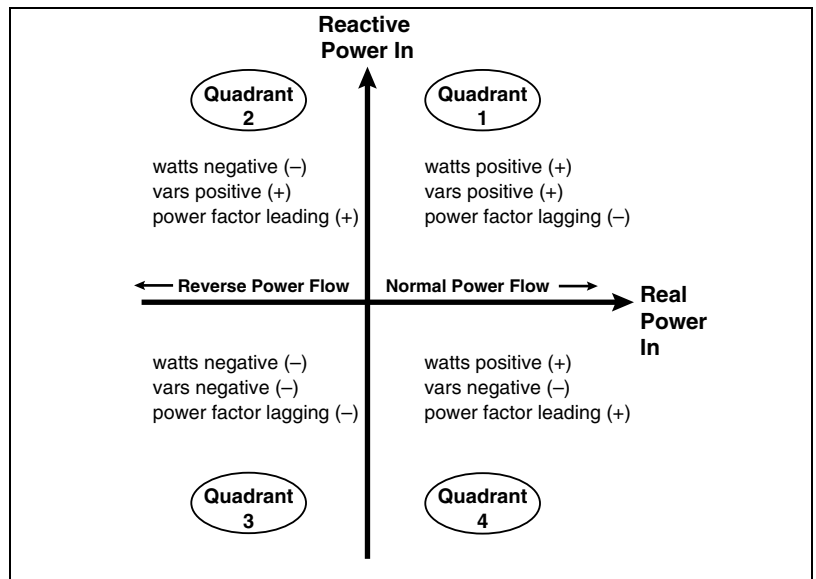

Figure 4–7: Reactive energy accumulates in four quadrants

POWER ANALYSIS VALUES

The circuit monitor provides a number of power analysis values that can be used to detect power quality problems, diagnose wiring problems, and more. Table 4–4 on page 66 summarizes the power analysis values.

- **THD.** Total Harmonic Distortion (THD) is a quick measure of the total distortion present in a waveform and is the ratio of harmonic content to the fundamental. It provides a general indication of the “quality” of a waveform. THD is calculated for both voltage and current. The circuit monitor uses the following equation to calculate THD where H is the harmonic distortion:

$$\text{THD} = \frac{\sqrt{H_2^2 + H_3^2 + H_4^2 + \dots}}{H_1} \times 100\%$$

- **thd.** An alternate method for calculating Total Harmonic Distortion, used widely in Europe. It considers the total harmonic current and the total rms content rather than fundamental content in the calculation. The circuit monitor calculates thd for both voltage and current. The circuit monitor uses the following equation to calculate thd where H is the harmonic distortion:

$$\text{thd} = \frac{\sqrt{H_2^2 + H_3^2 + H_4^2 + \dots}}{\text{Total rms}} \times 100\%$$

- **TDD.** Total Demand Distortion (TDD) is used to evaluate the harmonic voltages and currents between an end user and a power source. The harmonic values are based on a point of common coupling (PCC), which is a common point that each user receives power from the power source. The following equation is used to calculate TDD where I_h is the magnitude of individual harmonic components, h is the harmonic order, and I_L is the maximum demand load current in register 3233:

$$\text{TDD} = \frac{\sqrt{\sum_{h=2}^{255} I_h^2}}{I_L} \times 100\%$$

- **K-factor.** K-factor is a simple numerical rating used to specify transformers for nonlinear loads. The rating describes a transformer’s ability to serve nonlinear loads without exceeding rated temperature rise limits. The higher the K-factor rating, the better the transformer’s ability to handle the harmonics. The circuit monitor uses the following equation to calculate K-factor where I_h is harmonic current and h is the harmonic order:

$$K = \frac{\text{SUM } (I_h^2 \cdot h^2)}{\text{SUM } I_{\text{rms}}^2}$$

- **Displacement Power Factor.** Power factor (PF) represents the degree to which voltage and current coming into a load are out of phase. When true power factor is based on the angle between the fundamental components of current and voltage.
- **Harmonic Values.** Harmonics can reduce the capacity of the power system. The circuit monitor determines the individual per-phase harmonic magnitudes and angles through the 63rd harmonic for all currents and voltages. The harmonic magnitudes can be formatted as either a percentage of the fundamental (default) or a percentage of the rms value. Refer to “Setting Up Individual Harmonic Calculations” on page 208 in **Appendix B—Using the Command Interface** for information on how to configure harmonic calculations.
- **Harmonic Power.** Harmonic power is an indication of the non-fundamental components of current and power in the electrical circuit. The circuit monitor uses the following equation to calculate harmonic power.

$$\text{Harmonic Power} = \sqrt{\text{Overall Power}^2 - \text{Fundamental Power}^2}$$

- **Distortion Power Factor.** Distortion power factor is an indication of the distortion power content of non-linear loads. Linear loads do not contribute to distortion power even when harmonics are present. Distortion power factor provides a way to describe distortion in terms of its total contribution to apparent power. The circuit monitor uses the following equation to calculate the distortion power factor.

$$\text{Distortion Power Factor} = \frac{\text{Overall Power Power Factor}}{\text{Fundamental Power Power Factor}}$$

Table 4–4: Power Analysis Values

Value	Reportable Range
THD—Voltage, Current 3-phase, per-phase, neutral	0 to 3,276.7%
thd—Voltage, Current 3-phase, per-phase, neutral	0 to 3,276.7%
Total Demand Distortion	0 to 10,000
K-Factor (per phase) ^②	0.0 to 100.0
K-Factor Demand (per phase) ^{①②}	0.0 to 100.0
Crest Factor (per phase) ^①	0.0 to 100.0
Displacement P.F. (per phase, 3-phase) ^①	–0.010 to 1.000 to +0.010
Fundamental Voltages (per phase) Magnitude Angle	0 to 1,200 kV 0.0 to 359.9°
Fundamental Currents (per phase) Magnitude Angle	0 to 32,767 A 0.0 to 359.9°
Fundamental Real Power (per phase, 3-phase) ^①	0 to 32,767 kW
Fundamental Reactive Power (per phase) ^①	0 to 32,767 kVAR
Harmonic Power (per phase, 3-phase) ^①	0 to 32,767 kW
Phase Rotation	ABC or CBA
Unbalance (current and voltage) ^①	0.0 to 100.0%
Individual Harmonic Magnitudes ^{①③}	0 to 327.67%
Individual Harmonic Angles ^{①③}	0.0° to 359.9°
Distortion Power	–32,767 to 32,767
Distortion Power Factor	0 to 1,000

^① Readings are obtained only through communications.

^② K-Factor not available at 400Hz.

^③ Harmonic magnitudes and angles through the 63rd harmonic at 50Hz and 60Hz;
harmonic magnitudes and angles through the 7th harmonic at 400Hz.

CHAPTER 5—INPUT/OUTPUT CAPABILITIES

This chapter explains the input and output (I/O) capabilities of the circuit monitor and its optional I/O accessories. For module installation instructions and detailed technical specifications, refer to the individual instruction bulletins that ship with the product. For a list of these publications, see Table 1–2 on page 3 of this bulletin.

CHAPTER CONTENTS

CHAPTER CONTENTS	67
I/O OPTIONS	68
DIGITAL INPUTS	69
DEMAND SYNCH PULSE INPUT	70
RELAY OUTPUT OPERATING MODES	71
MECHANICAL RELAY OUTPUTS	73
Setpoint-controlled Relay Functions	74
SOLID-STATE KYZ PULSE OUTPUT	74
2-Wire Pulse Initiator	75
3-Wire Pulse Initiator	75
CALCULATING THE KILOWATTHOUR-PER-PULSE VALUE	76

I/O OPTIONS

The circuit monitor supports a variety of input and output options including:

- Digital Inputs
- Mechanical Relay Outputs
- Solid State KYZ Pulse Outputs

The circuit monitor has one KYZ output as standard. You can expand the I/O capabilities by adding the digital I/O option card (IOC-44). The I/O options are explained in detail in the sections that follow.

DIGITAL INPUTS

The circuit monitor can accept up to four digital inputs with the IOC-44 option card. Digital inputs are used to detect digital signals. For example, the digital input can be used to determine circuit breaker status, count pulses, or count motor starts. Digital inputs can also be associated with an external relay, which can trigger a waveform capture in the circuit monitor. You can log digital input transitions as events in the circuit monitor's on-board alarm log. The event is date and time stamped with resolution to the millisecond, for sequence of events recording. The circuit monitor counts OFF-to-ON transitions for each input, and you can reset this value using the command interface.

Digital inputs have four operating modes:

- **Normal**—Use the normal mode for simple on/off digital inputs. In normal mode, digital inputs can be used to count KYZ pulses for demand and energy calculation. Using the input pulse demand feature, you can map multiple inputs to the same channel where the circuit monitor can total pulses from multiple inputs (see “Input Pulse Demand Metering” on page 60 in **Chapter 4—Metering Capabilities** for more information). To accurately count pulses, set the time between transitions from OFF to ON and ON to OFF to at least 20 milliseconds.
- **Demand Interval Synch Pulse**—you can configure any digital input to accept a demand synch pulse from a utility demand meter (see “Demand Synch Pulse Input” on page 70 of this chapter for more about this topic). For each demand profile, you can designate only one input as a demand synch input.
- **Time Synch**—you can configure one digital input to receive a signal from a GPS receiver that provides a serial pulse stream in accordance to the DCF-77 format to synchronize the internal clock of the circuit monitor.
- **Conditional Energy Control**—you can configure one digital input to control conditional energy (see “Energy Readings” on page 61 in **Chapter 4—Metering Capabilities** for more about conditional energy).

Using SMS, define the name and operating mode of the digital input. The name is a 16-character label that identifies the digital input. The operating mode is one of those listed above. See the SMS online help for instructions on device set up of the circuit monitor.

DEMAND SYNCH PULSE INPUT

You can configure the circuit monitor to accept a demand synch pulse from an external source such as another demand meter. By accepting demand synch pulses through a digital input, the circuit monitor can make its demand interval “window” match the other meter’s demand interval “window.” The circuit monitor does this by “watching” the digital input for a pulse from the other demand meter. When it sees a pulse, it starts a new demand interval and calculates the demand for the preceding interval. The circuit monitor then uses the same time interval as the other meter for each demand calculation. Figure 5–1 illustrates this point. See “Synchronized Demand” on page 57 in **Chapter 4—Metering Capabilities** for more about demand calculations.

When in demand synch pulse operating mode, the circuit monitor will not start or stop a demand interval without a pulse. The maximum allowable time between pulses is 60 minutes. If 66 minutes (110% of the demand interval) pass before a synch pulse is received, the circuit monitor throws out the demand calculations and begins a new calculation when the next pulse is received. Once in synch with the billing meter, the circuit monitor can be used to verify peak demand charges.

Important facts about the circuit monitor’s demand synch feature are listed below:

- Any installed digital input can be set to accept a demand synch pulse.
- Each system can choose whether to use an external synch pulse, but only one demand synch pulse can be brought into the meter for each demand system. One input can be used to synchronize any combination of the demand systems.
- The demand synch feature can be set up from SMS. See the SMS online help for instructions on device set up of the circuit monitor.

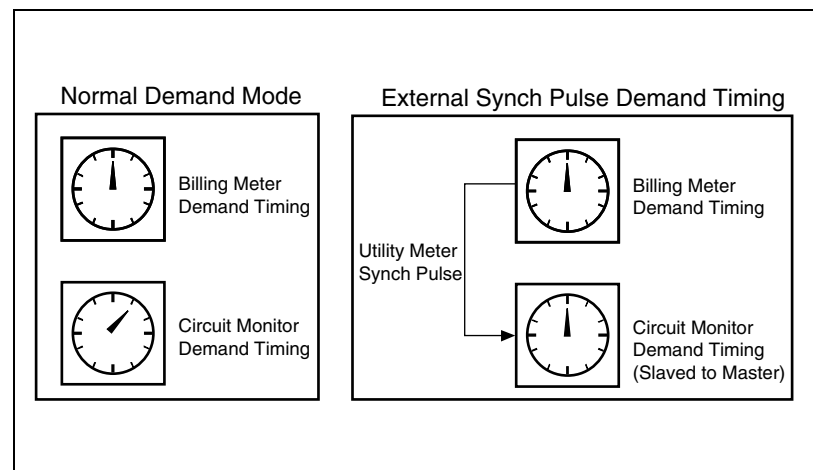

Figure 5–1: Demand synch pulse timing

RELAY OUTPUT OPERATING MODES

Before we describe the 11 available relay operating modes, it is important to understand the difference between a relay configured for remote (external) control and a relay configured for circuit monitor (internal) control.

Each relay output defaults to external control, but you can choose whether the relay is set to external or internal control:

- **Remote (external) control**—the relay is controlled either from a PC using SMS or a programmable logic controller using commands via communications.
- **Circuit monitor (internal) control**—the relay is controlled by the circuit monitor in response to a set-point controlled alarm condition, or as a pulse initiator output. Once you've set up a relay for circuit monitor control, you can no longer operate the relay remotely. However, you can temporarily override the relay, using SMS.

NOTE: If any basic setup parameters or I/O setup parameters are modified, all relay outputs will be de-energized.

The 11 relay operating modes are as follows:

- **Normal**
 - *Remotely Controlled:* Energize the relay by issuing a command from a remote PC or programmable controller. The relay remains energized until a command to de-energize is issued from the remote PC or programmable controller, or until the circuit monitor loses control power. When control power is restored, the relay will be re-energized.
 - *Circuit Monitor Controlled:* When an alarm condition assigned to the relay occurs, the relay is energized. The relay is not de-energized until *all* alarm conditions assigned to the relay have dropped out, the circuit monitor loses control power, or the alarms are over-ridden using SMS software. If the alarm condition is still true when the circuit monitor regains control power, the relay will be re-energized.
- **Latched**
 - *Remotely Controlled:* Energize the relay by issuing a command from a remote PC or programmable controller. The relay remains energized until a command to de-energize is issued from a remote PC or programmable controller, or until the circuit monitor loses control power. When control power is restored, the relay will not be re-energized.
 - *Circuit Monitor Controlled:* When an alarm condition assigned to the relay occurs, the relay is energized. The relay remains energized—even after all alarm conditions assigned to the relay have dropped out—until a command to de-energize is issued from a remote PC or programmable controller, until the high priority alarm log is cleared from the display, or until the circuit monitor loses control power. When control power is restored, the relay will not be re-energized if the alarm condition is not TRUE.

- **Timed**
 - *Remotely Controlled:* Energize the relay by issuing a command from a remote PC or programmable controller. The relay remains energized until the timer expires, or until the circuit monitor loses control power. If a new command to energize the relay is issued before the timer expires, the timer restarts. If the circuit monitor loses control power, the relay will be re-energized when control power is restored and the timer will reset to zero and begin timing again.
 - *Circuit Monitor Controlled:* When an alarm condition assigned to the relay occurs, the relay is energized. The relay remains energized for the duration of the timer. When the timer expires, the relay will de-energize and remain de-energized. If the relay is on and the circuit monitor loses control power, the relay will be re-energized when control power is restored and the timer will reset to zero and begin timing again.
- **End Of Power Demand Interval**

This mode assigns the relay to operate as a synch pulse to another device. The output operates in timed mode using the timer setting and turns on at the end of a power demand interval. It turns off when the timer expires. Because of its long life, this mode should be used with solid state relay outputs.
- **Absolute kWh Pulse**

This mode assigns the relay to operate as a pulse initiator with a user-defined number of kWh per pulse. In this mode, both forward and reverse real energy are treated as additive (as in a tie circuit breaker).
- **Absolute kVARh Pulse**

This mode assigns the relay to operate as a pulse initiator with a user-defined number of kVARh per pulse. In this mode, both forward and reverse reactive energy are treated as additive (as in a tie circuit breaker).
- **kVAh Pulse**

This mode assigns the relay to operate as a pulse initiator with a user-defined number of kVAh per pulse. Since kVA has no sign, the kVAh pulse has only one mode.
- **kWh In Pulse**

This mode assigns the relay to operate as a pulse initiator with a user-defined number of kWh per pulse. In this mode, only the kWh flowing into the load is considered.
- **kVARh In Pulse**

This mode assigns the relay to operate as a pulse initiator with a user-defined number of kVARh per pulse. In this mode, only the kVARh flowing into the load is considered.
- **kWh Out Pulse**

This mode assigns the relay to operate as a pulse initiator with a user-defined number of kWh per pulse. In this mode, only the kWh flowing out of the load is considered.
- **kVARh Out Pulse**

This mode assigns the relay to operate as a pulse initiator with a user-defined number of kVARh per pulse. In this mode, only the kVARh flowing out of the load is considered.

MECHANICAL RELAY OUTPUTS

The optional Input/Output Card IOC44 provides three Form-C, 10 A mechanical relays that can be used to open or close circuit breakers, announce alarms, and more.

The mechanical output relays of the circuit monitor can be configured to operate in one of 11 operating modes:

- Normal
- Latched (electrically held)
- Timed
- End of power demand interval
- Absolute kWh pulse
- Absolute kVARh pulse
- kVAh pulse
- kWh in pulse
- kVARh in pulse
- kWh out pulse
- kVARh out pulse

See the previous section “Relay Output Operating Modes” on page 71 for a description of the modes.

The last seven modes in the list above are for pulse initiator applications. All Series 3000 Circuit Monitors are equipped with one solid-state KYZ pulse output rated at 96 mA and an additional KYZ pulse output is available on the IOC44 card. The solid-state KYZ output provides the long life—billions of operations—required for pulse initiator applications. The mechanical relay outputs have limited lives: 10 million operations under no load; 100,000 under load. For maximum life, use the solid-state KYZ pulse output for pulse initiation, except when a rating higher than 96 mA is required. See “Solid-State KYZ Pulse Output” on page 74 in this chapter for a description of the solid-state KYZ pulse output.

To set up a mechanical relay output, from the Main Menu, select Setup > I/O. Select input option IOC44. For detailed instructions, see “Setting Up I/Os” on page 24 in **Chapter 3—Operation**. Then using SMS, you must define the following values for each mechanical relay output:

- **Name**—A 16-character label used to identify the digital output.
- **Mode**—Select one of the operating modes listed above.
- **Pulse Weight**—You must set the pulse weight, the multiplier of the unit being measured, if you select any of the pulse modes (last 7 listed above).
- **Timer**—You must set the timer if you select the timed mode or end of power demand interval mode (in seconds).
- **Control**—You must set the relay to be controlled either remotely or internally (from the circuit monitor) if you select the normal, latched, or timed mode.

For instructions on setting up digital I/Os in SMS, see the SMS online help on device set up of the circuit monitor.

NOTE: The IOC44 can be set up using the display or SMS.

Setpoint-controlled Relay Functions

The circuit monitor can detect over 100 alarm conditions, including over/under conditions, digital input changes, phase unbalance conditions, and more (see **Chapter 6—Alarms** on page 77 for more about alarms). Using SMS, you can configure a relay to operate when an alarm condition is true. For example, you could set up the three relays on the IOC-44 card to operate at each occurrence of “Undervoltage Phase A.” Then, each time the alarm condition occurs—that is, each time the setpoints and time delays assigned to Undervoltage Phase A are satisfied—the circuit monitor automatically operates relays R1, R2, and R3 according to their configured mode of operation. See “Relay Output Operating Modes” on page 71 of this chapter for a description of the operating modes.

Also, you can assign multiple alarm conditions to a relay. For example, relay AR1 on the IOC-44 card could have “Undervoltage Phase A” and “Undervoltage Phase B” assigned to it. The relay would operate whenever either condition occurred.

*NOTE: Setpoint-controlled relay operation can be used for some types of non-time-critical relaying. For more information, see “Setpoint-Controlled Relay Functions” on page 82 in **Chapter 6—Alarms**.*

SOLID-STATE KYZ PULSE OUTPUT

This section describes the pulse output capabilities of the circuit monitor. For instructions on wiring the KYZ pulse output, see “Wiring the Solid-State KYZ Output” in **Chapter 5—Wiring** of the installation manual.

The circuit monitor is equipped with one solid-state KYZ pulse output located near the option card slot. The IOC44 option card also has a solid-state KYZ output. The solid-state relays provides the extremely long life—billions of operations—required for pulse initiator applications.

The KYZ output is a Form-C contact with a maximum rating of 100 mA. Because most pulse initiator applications feed solid-state receivers with low burdens, this 100 mA rating is adequate for most applications. For applications where a higher rating is required, the IOC-44 card provides 3 relays with 10 ampere ratings. Use SMS or the display to configure any of the 10 ampere relays as a pulse initiator output. Keep in mind that the 10 ampere relays are mechanical relays with limited life—10 million operations under no load; 100,000 under load.

To set the kilowatthour-per-pulse value, use SMS or the display. When setting the kWh/pulse value, set the value based on a 3-wire pulse output. For instructions on calculating the correct value, see “Calculating the Kilowatthour-Per-Pulse Value” on page 76 in this chapter.

The circuit monitor can be used in 2-wire or 3-wire pulse initiator applications. Each of these applications is described in the sections that follow.

The KYZ pulse output can be configured to operate in one of 11 operating modes. See “Relay Output Operating Modes” on page 71 for a description of the modes.

The setup in SMS or at the circuit monitor display is the same as a mechanical relay. See the previous section “Mechanical Relay Outputs” on page 73, for the values you must set up in SMS.

2-Wire Pulse Initiator

Most digital inputs in energy management systems use only two of the three wires provided with a KYZ pulse initiator. This is called a 2-wire pulse initiator application. Figure 5–2 shows a pulse train from a 2-wire pulse initiator application.

In a 2-wire application, the pulse train looks like the alternating open and closed states of a Form-A contact. Most 2-wire pulse initiator applications use a Form-C contact, but tie into only one side of the Form-C contact where the pulse is the transition from OFF to ON of that side of the Form-C relay. In Figure 5–2, the transitions are marked as 1 and 2. Each transition represents the time when the relay transitions from KZ to KY. Each time the relay transitions, the receiver counts a pulse. The circuit monitor can deliver up to 25 pulses per second in a 2-wire application.

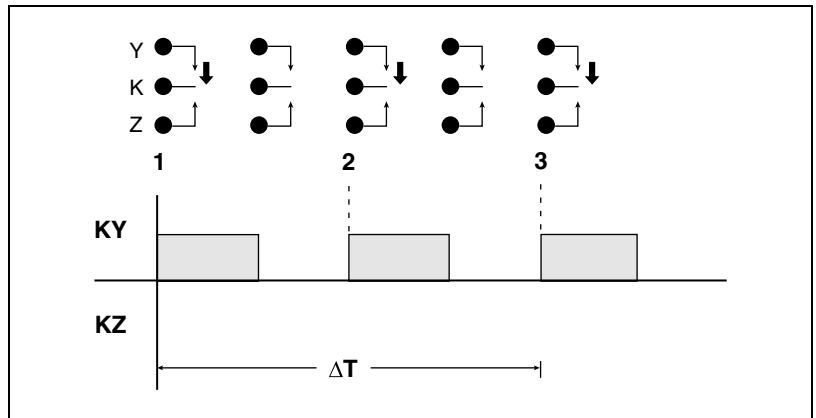

Figure 5–2: Two-wire pulse train

3-Wire Pulse Initiator

Some applications require the use of all three wires provided with the KYZ pulse initiator. This is called a 3-wire pulse initiator application. Figure 5–3 shows a pulse train for a 3-wire pulse initiator application.

Three-wire KYZ pulses are the transitions between KY and KZ. These transitions are the alternate contact closures of a Form-C contact. In Figure 5–3, the transitions are marked as 1, 2, 3, and 4. The receiver counts a pulse at each transition. That is, each time the Form-C contact changes state from KY to KZ, or from KZ to KY, the receiver counts a pulse. The circuit monitor can deliver up to 50 pulses per second in a 3-wire application.

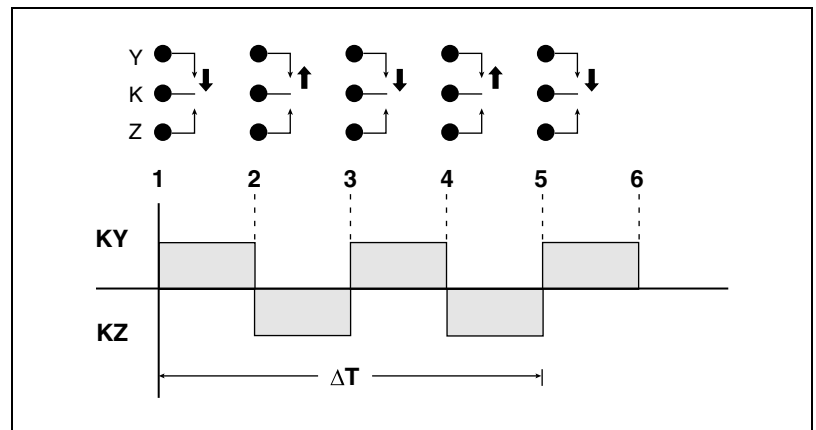

Figure 5–3: Three-wire pulse train

CALCULATING THE KILOWATTHOUR-PER-PULSE VALUE

This section shows an example of how to calculate kilowatthours per pulse. To calculate this value, first determine the highest kW value you can expect and the required pulse rate. In this example, the following assumptions are made:

- The metered load should not exceed 1600 kW.
- About two KYZ pulses per second should occur at full scale.

Step 1: Convert 1600 kW load into kWh/second.

$$(1600 \text{ kW}) (1 \text{ Hr}) = 1600 \text{ kWh}$$

$$\frac{(1600 \text{ kWh})}{1 \text{ hour}} = \frac{\text{“X” kWh}}{1 \text{ second}}$$

$$\frac{(1600 \text{ kWh})}{3600 \text{ seconds}} = \frac{\text{“X” kWh}}{1 \text{ second}}$$

$$X = 1600/3600 = 0.4444 \text{ kWh/second}$$

Step 2: Calculate the kWh required per pulse.

$$\frac{0.4444 \text{ kWh/second}}{2 \text{ pulses/second}} = 0.2222 \text{ kWh/pulse}$$

Step 3: Round to nearest hundredth, since the circuit monitor only accepts 0.01 kWh increments.

$$K_e = 0.22 \text{ kWh/pulse}$$

Summary:

- 3-wire application—**0.22 kWh/pulse** provides approximately 2 pulses per second at full scale.
- 2-wire application—**0.11 kWh/pulse** provides approximately 2 pulses per second at full scale. (To convert to the kWh/pulse required for a 2-wire application, divide K_e by 2. This is necessary because the circuit monitor Form C relay generates two pulses—KY and KZ—for every pulse that is counted.)

CHAPTER 6—ALARMS

This chapter provides a detailed discussion of the alarm capabilities of the circuit monitor.

CHAPTER CONTENTS

CHAPTER CONTENTS	77
ABOUT ALARMS	78
Alarms Groups	78
Setpoint-Driven Alarms	79
Priorities	81
Alarm Levels	81
CUSTOM ALARMS	82
SETPOINT-CONTROLLED RELAY FUNCTIONS	82
Types of Setpoint-Controlled Relay Functions	83
SCALE FACTORS	85
SCALING ALARM SETPOINTS	86
ALARM CONDITIONS AND ALARM NUMBERS	87

ABOUT ALARMS

The circuit monitor can detect over 100 alarm conditions, including over or under conditions, digital input changes, phase unbalance conditions, and more. It also maintains a counter for each alarm to keep track of the total number of occurrences. A complete list of default alarm configurations are described in Table 6–3 on page 88. In addition, you can set up your own custom alarms and set up relays to operate on alarm conditions.

When one or more alarm conditions are true, the circuit monitor will execute a task automatically. Using SMS or the display, you can set up each alarm condition to perform these tasks:

- Force data log entries in up to 14 user-defined data log files. See **Chapter 7—Logging** on page 93 for more about data logging.
- Perform event captures. See **Chapter 8—Waveform and Event Capture** on page 101 for more about event recording.
- Operate relays. Using SMS you can assign one or more relays to operate when an alarm condition is true. See the SMS online help for more about this topic.

Alarms Groups

Whether you are using a default alarm or creating a custom alarm, you first choose the alarm group that is appropriate for the application. Each alarm condition is assigned to one of these alarm groups:

- **Standard**—Standard alarms have a detection rate of 1 second and are useful for detecting conditions such as over current and under voltage. Up to 80 alarms can be set up in this alarm group
- **High Speed**—High speed alarms have a detection rate of 100 milliseconds and are useful for detecting voltage sags and swells lasting only a few cycles. Up to 20 alarms can be set up in this group.
- **Disturbance (CM3350 only)**—Disturbance alarms have a detection rate one cycle and are useful for detecting voltage sags and swells. Up to 20 alarms can be set up in this group. See **Chapter 9—Disturbance Monitoring (CM3350)** on page 107 for more about disturbance monitoring.
- **Digital**—Digital alarms are triggered by an exception such as the transition of a digital input or the end of an incremental energy interval. Up to 40 alarms can be set up in this group.
- **Boolean**—Boolean alarms use Boolean logic to combine up to four enabled alarms. You can choose from the Boolean logic operands: AND, NAND, OR, NOR, or XOR to combine your alarms. Up to 15 alarms can be set up in this group.

Use either SMS or the display to set up any of the alarms.

Setpoint-Driven Alarms

Many of the alarm conditions require that you define setpoints. This includes all alarms for over, under, and phase unbalance alarm conditions. Other alarm conditions such as digital input transitions and phase reversals do not require setpoints. For those alarm conditions that require setpoints, you must define the following information:

- Pickup Setpoint
- Pickup Delay (depending on the alarm group, you choose the time in seconds, 100 ms increments, or cycles)
- Dropout Setpoint
- Dropout Delay (depending on the alarm group, you choose the time in seconds, 100 ms increments, or cycles)

NOTE: Alarms with both Pickup and Dropout setpoints set to zero are invalid.

To understand how the circuit monitor handles setpoint-driven alarms, see Figure 6–2 on page 80. Figure 6–1 shows what the actual alarm Log entries for Figure 6–2 might look like, as displayed by SMS.

NOTE: The software does not actually display the codes in parentheses—EV1, EV2, Max1, Max2. These are references to the codes in Figure 6–2.

(EV2)

(Max2)

Time	Device	Type	Function	Value	State	Level
03/14/2001 5:16:34.998 PM	CM4000 Office	0	Swell Ib	690	Voltage/Current Swell Dropout	3
03/14/2001 5:16:34.981 PM	CM4000 Office	0	Swell Ia	690	Voltage/Current Swell Dropout	2
03/14/2001 5:16:31.297 PM	CM4000 Office	0	Swell Ia	685	Voltage/Current Swell Pickup	2
03/14/2001 5:16:31.181 PM	CM4000 Office	0	Swell Ia	651	Voltage/Current Swell Dropout	2
03/14/2001 5:16:31.031 PM	CM4000 Office	0	Swell Ia	670	Voltage/Current Swell Pickup	2
03/14/2001 5:16:30.997 PM	CM4000 Office	0	Swell Ib	653	Voltage/Current Swell Pickup	3
03/14/2001 3:39:28.404 PM	CM4000 Office	0	Swell Ib	674	Voltage/Current Swell Dropout	3

(EV1)

(Max1)

Figure 6-1: Sample alarm log entry

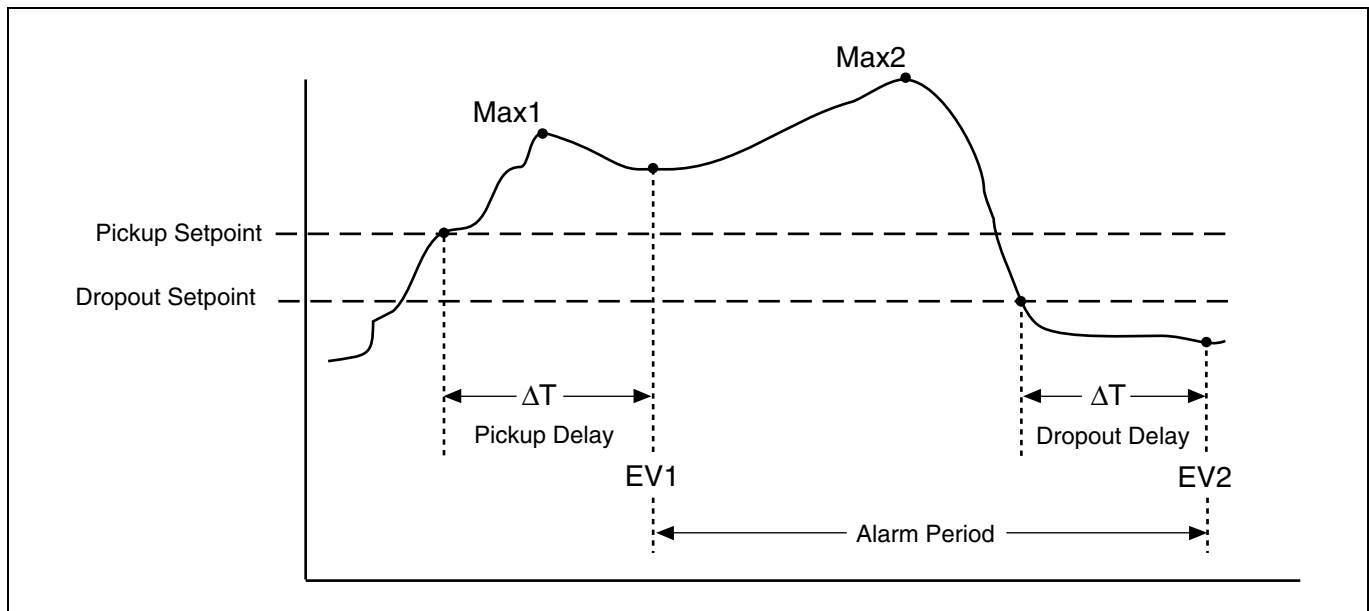

Figure 6-2: How the circuit monitor handles setpoint-driven alarms

EV1—The circuit monitor records the date and time that the pickup setpoint and time delay were satisfied, and the maximum value reached (Max1) during the pickup delay period (ΔT). Also, the circuit monitor performs any tasks assigned to the event such as waveform captures or forced data log entries.

EV2—The circuit monitor records the date and time that the dropout setpoint and time delay were satisfied, and the maximum value reached (Max2) during the alarm period.

The circuit monitor also stores a correlation sequence number (CSN) for each event (such as *Under Voltage Phase A Pickup*, *Under Voltage Phase A Dropout*). The CSN lets you relate pickups and dropouts in the alarm log. You can sort pickups and dropouts by CSN to correlate the pickups and dropouts of a particular alarm. The pickup and dropout entries of an alarm will have the same CSN. You can also calculate the duration of an event by looking at pickups and dropouts with the same CSN.

CUSTOM ALARMS

The circuit monitor has many pre-defined alarms, but you can also set up your own custom alarms. For example, you may need to alarm on the ON-to-OFF transition of a digital input. To create this type of custom alarm:

1. Select the appropriate alarm group (digital in this case).
2. Select the type of alarm (described in Table 6–4 on page 90).
3. Give the alarm a name.

After creating a custom alarm, you can configure it by applying priorities, setting pickups and dropouts (if applicable), and so forth. For instructions on creating custom alarms, see “Creating a New Custom Alarm” on page 20 in **Chapter 3—Operation**.

NOTE: The circuit monitor will automatically create alarms for the IOC-44. These are OFF-to-ON alarms.

SETPOINT-CONTROLLED RELAY FUNCTIONS

A circuit monitor can mimic the functions of certain motor management devices to detect and respond to conditions such as phase loss, undervoltage, or reverse phase relays. While the circuit monitor is not a primary protective device, it can detect abnormal conditions and respond by operating one or more Form-C output contacts. These outputs can be used to operate an alarm horn or bell to annunciate the alarm condition.

NOTE: The circuit monitor is not designed for use as a primary protective relay. While its setpoint-controlled functions may be acceptable for certain applications, it should not be considered a substitute for proper circuit protection.

If you determine that the circuit monitor’s performance is acceptable for the application, the output contacts can be used to mimic some functions of a motor management device. When deciding if the circuit monitor is acceptable for these applications, keep the following points in mind:

- Circuit monitors require control power to operate properly.
- Circuit monitors may take up to 5 seconds after control power is applied before setpoint-controlled functions are activated. If this is too long, a reliable source of control power is required.
- When control power is interrupted for more than approximately 100 milliseconds, the circuit monitor releases all energized output contacts.
- Standard setpoint-controlled functions may take 1–2 seconds to operate, in addition to the intended delay.
- A password is required to program the circuit monitor’s setpoint controlled relay functions.
- Changing certain setup parameters after installation may operate relays in a manner inconsistent with the requirements of the application.

For instructions on configuring setpoint-controlled alarms or relays from the circuit monitor’s display, see “Setting Up and Editing Alarms” on page 21. The types of available alarms are described later in this chapter in Table 6–3 on page 88.

Types of Setpoint-Controlled Relay Functions

This section describes some common motor management functions to which the following information applies:

- Values that are too large to fit into the display may require scale factors. For more information on scale factors, refer to “Changing Scale Factors” on page 209 in **Appendix B—Using the Command Interface**.
- Relays can be configured as normal, latched, or timed. See “Relay Output Operating Modes” on page 71 in **Chapter 5—Input/Output Capabilities** for more information.
- When the alarm occurs, the circuit monitor operates any specified relays. There are two ways to release relays that are in latched mode:
 - Issue a command to de-energize a relay. See **Appendix B—Using the Command Interface** on page 199 for instructions on using the command interface, or
 - Acknowledge the alarm in the high priority log to release the relays from latched mode. From the main menu of the display, select View Alarms > High Priority Log to view and acknowledge unacknowledged alarms. See “Viewing Alarms” on page 40 for detailed instructions.

The list that follows shows the types of alarms available for some common motor management functions:

NOTE: Voltage base alarm setpoints depend on your system configuration. Alarm setpoints for 3-wire systems are V_{L-L} values while 4-wire systems are V_{L-N} values.

Undervoltage:

Pickup and dropout setpoints are entered in volts. The per-phase undervoltage alarm occurs when the per-phase voltage is equal to or below the pickup setpoint long enough to satisfy the specified pickup delay (in seconds). The undervoltage alarm clears when the phase voltage remains above the dropout setpoint for the specified dropout delay period.

Overvoltage:

Pickup and dropout setpoints are entered in volts. The per-phase overvoltage alarm occurs when the per-phase voltage is equal to or above the pickup setpoint long enough to satisfy the specified pickup delay (in seconds). The overvoltage alarm clears when the phase voltage remains below the dropout setpoint for the specified dropout delay period.

Unbalance Current:

Pickup and dropout setpoints are entered in tenths of percent, based on the percentage difference between each phase current with respect to the average of all phase currents. For example, enter an unbalance of 7% as 70. The unbalance current alarm occurs when the phase current deviates from the average of the phase currents, by the percentage pickup setpoint, for the specified pickup delay. The alarm clears when the percentage difference between the phase current and the average of all phases remains below the dropout setpoint for the specified dropout delay period.

Unbalance Voltage:

Pickup and dropout setpoints are entered in tenths of percent, based on the percentage difference between each phase voltage with respect to the average of all phase voltages. For example, enter an unbalance of 7% as 70. The unbalance voltage alarm occurs when the phase voltage deviates from the average of the phase voltages, by the percentage pickup setpoint, for the specified pickup delay. The alarm clears when the percentage difference between the phase voltage and the average of all phases remains below the dropout setpoint for the specified dropout delay (in seconds).

Phase Loss—Current:

Pickup and dropout setpoints are entered in amperes. The phase loss current alarm occurs when any current value (but not all current values) is equal to or below the pickup setpoint for the specified pickup delay (in seconds). The alarm clears when one of the following is true:

- All of the phases remain above the dropout setpoint for the specified dropout delay, or
- All of the phases drop below the phase loss pickup setpoint.

If all of the phase currents are equal to or below the pickup setpoint, during the pickup delay, the phase loss alarm will not activate. This is considered an under current condition. It should be handled by configuring the under current protective functions.

Phase Loss—Voltage:

Pickup and dropout setpoints are entered in volts. The phase loss voltage alarm occurs when any voltage value (but not all voltage values) is equal to or below the pickup setpoint for the specified pickup delay (in seconds). The alarm clears when one of the following is true:

- All of the phases remain above the dropout setpoint for the specified dropout delay (in seconds), OR
- All of the phases drop below the phase loss pickup setpoint.

If all of the phase voltages are equal to or below the pickup setpoint, during the pickup delay, the phase loss alarm will not activate. This is considered an under voltage condition. It should be handled by configuring the under voltage protective functions.

Reverse Power:

Pickup and dropout setpoints are entered in kilowatts or kVARs. The reverse power alarm occurs when the power flows in a negative direction and remains at or below the negative pickup value for the specified pickup delay (in seconds). The alarm clears when the power reading remains above the dropout setpoint for the specified dropout delay (in seconds).

Phase Reversal:

Pickup and dropout setpoints and delays do not apply to phase reversal. The phase reversal alarm occurs when the phase voltage rotation differs from the default phase rotation. The circuit monitor assumes that an ABC phase rotation is normal. If a CBA phase rotation is normal, the user must change the circuit monitor's phase rotation from ABC (default) to CBA. To change the phase rotation from the display, from the main menu select Setup > Meter > Advanced. For more information about changing the phase rotation setting of the circuit monitor, refer to "Advanced Meter Setup" on page 33.

SCALE FACTORS

A scale factor is the multiplier expressed as a power of 10. For example, a multiplier of 10 is represented as a scale factor of 1, since $10^1=10$; a multiplier of 100 is represented as a scale factor of 2, since $10^2=100$. This allows you to make larger values fit into the register. Normally, you do not need to change scale factors. If you are creating custom alarms, you need to understand how scale factors work so that you do not overflow the register with a number larger than what the register can hold. When SMS is used to set up alarms, it automatically handles the scaling of pickup and dropout setpoints. When creating a custom alarm using the circuit monitor's display, do the following:

- Determine how the corresponding metering value is scaled, and
- Take the scale factor into account when entering alarm pickup and dropout settings.

Pickup and dropout settings must be integer values in the range of -32,767 to +32,767. For example, to set up an under voltage alarm for a 138 kV nominal system, decide upon a setpoint value and then convert it into an integer between -32,767 and +32,767. If the under voltage setpoint were 125,000 V, this would typically be converted to 12500×10 and entered as a setpoint of 12500.

Six scale groups are defined (A through F). The scale factor is preset for all factory-configured alarms. Table 6–1 lists the available scale factors for each of the scale groups. If you need either an extended range or more resolution, select any of the available scale factors to suit your need. Refer to “Changing Scale Factors” on page 209 in **Appendix B—Using the Command Interface**.

Table 6–1: Scale Groups

Scale Group	Measurement Range	Scale Factor
Scale Group A—Phase Current	Amperes	
	0–327.67 A	–2
	0–3,276.7 A	–1
	0–32,767 A	0 (default)
Scale Group B—Neutral Current	0–327.67 kA	1
	Amperes	
	0–327.67 A	–2
	0–3,276.7 A	–1
Scale Group C—Ground Current	0–32,767 A	0 (default)
	0–327.67 kA	1
	Amperes	
	0–327.67 A	–2
Scale Group D—Phase Voltage	0–3,276.7 V	–1
	0–32,767 V	0 (default)
	0–327.67 kV	1
	Amperes	
Scale Group E—Neutral Voltage	0–327.67 A	–2
	0–3,276.7 A	–1
	0–32,767 A	0 (default)
	0–327.67 kA	1
Scale Group F—Ground Voltage	0–327.67 kA	1
	Amperes	
	0–327.67 A	–2
	0–3,276.7 A	–1

Table 6–1: Scale Groups

Scale Group	Measurement Range	Scale Factor
Scale Group D—Voltage	Voltage	
	0–3,276.7 V	–1
	0–32,767 V	0 (default)
	0–327.67 kV	1
	0–3,276.7 kV	2
Scale Group F—Power kW, kVAR, kVA	Power	
	0–32.767 kW, kVAR, kVA	–3
	0–327.67 kW, kVAR, kVA	–2
	0–3,276.7 kW, kVAR, kVA	–1
	0–32,767 kW, kVAR, kVA	0 (default)
	0–327.67 MW, MVAR, MVA	1
	0–3,276.7 MW, MVAR, MVA	2
	0–32,767 MW, MVAR, MVA	3

SCALING ALARM SETPOINTS

This section is for users who do not have SMS and must set up alarms from the circuit monitor display. It explains how to scale alarm setpoints.

When the circuit monitor is equipped with a display, the display area is 4 x 20 characters, which limits the displaying of most metered quantities to five characters (plus a positive or negative sign). The display will also show the engineering units applied to that quantity.

To determine the proper scaling of an alarm setpoint, view the register number for the associated scale group. The scale factor is the number in the Dec column for that register. For example, the register number for Scale D to Phase Volts is 3212. If the number in the Dec column is 1, the scale factor is 10 ($10^1=10$). Remember that scale factor 1 in Table 6–1 on page 85 for Scale Group D is measured in kV. Therefore, to define an alarm setpoint of 125 kV, enter 12.5 because 12.5 multiplied by 10 is 125. Below is a table listing the scale groups and their register numbers.

Table 6–2: Scale Group Register Numbers

Scale Group	Register Number
Scale Group A—Phase Current	3209
Scale Group B—Neutral Current	3210
Scale Group C—Ground Current	3211
Scale Group D—Voltage	3212
Scale Group F—Power kW, kVAR, kVA	3214

ALARM CONDITIONS AND ALARM NUMBERS

This section lists the circuit monitor's predefined alarm conditions. For each alarm condition, the following information is provided.

- **Alarm No.**—a position number indicating where an alarm falls in the list.
- **Alarm Description**—a brief description of the alarm condition
- **Abbreviated Display Name**—an abbreviated name that describes the alarm condition, but is limited to 15 characters that fit in the window of the circuit monitor's display.
- **Test Register**—the register number that contains the value (where applicable) that is used as the basis for a comparison to alarm pickup and dropout settings.
- **Units**—the unit that applies to the pickup and dropout settings.
- **Scale Group**—the scale group that applies to the test register's metering value (A–F). For a description of scale groups, see “Scale FactorS” on page 85.
- **Alarm Type**—a reference to a definition that provides details on the operation and configuration of the alarm. For a description of alarm types, refer to Table 6–4 on page 90.

Table 6–3 on page 88 lists the preconfigured alarms by alarm number.

Table 6-3: List of Default Alarms by Alarm Number

Alarm Number	Alarm Description	Abbreviated Display Name	Test Register	Units	Scale Group	Alarm Type ①
Standard Speed Alarms (1 Second)						
01	Over Current Phase A	Over Ia	1100	Amperes	A	010
02	Over Current Phase B	Over Ib	1101	Amperes	A	010
03	Over Current Phase C	Over Ic	1102	Amperes	A	010
04	Over Current Neutral	Over In	1103	Amperes	B	010
05	Over Current Ground	Over Ig	1104	Amperes	C	010
06	Under Current Phase A	Under Ia	1100	Amperes	A	020
07	Under Current Phase B	Under Ib	1101	Amperes	A	020
08	Under Current Phase C	Under Ic	1102	Amperes	A	020
09	Current Unbalance, Max	I Unbal Max	1110	Tenths %	—	010
10	Current Loss	Current Loss	3262	Amperes	A	053
11	Over Voltage Phase A-N	Over Van	1124	Volts	D	010
12	Over Voltage Phase B-N	Over Vbn	1125	Volts	D	010
13	Over Voltage Phase C-N	Over Vcn	1126	Volts	D	010
14	Over Voltage Phase A-B	Over Vab	1120	Volts	D	010
15	Over Voltage Phase B-C	Over Vbc	1121	Volts	D	010
16	Over Voltage Phase C-A	Over Vca	1122	Volts	D	010
17	Under Voltage Phase A	Under Van	1124	Volts	D	020
18	Under Voltage Phase B	Under Vbn	1125	Volts	D	020
19	Under Voltage Phase C	Under Vcn	1126	Volts	D	020
20	Under Voltage Phase A-B	Under Vab	1120	Volts	D	020
21	Under Voltage Phase B-C	Under Vbc	1121	Volts	D	020
22	Under Voltage Phase C-A	Under Vca	1122	Volts	D	020
23	Voltage Unbalance L-N, Max	V Unbal L-N Max	1136	Tenths %	—	010
24	Voltage Unbalance L-L, Max	V Unbal L-L Max	1132	Tenths %	—	010
25	Voltage Loss (loss of A,B,C, but not all)	Voltage Loss	3262	Volts	D	052
26	Phase Reversal	Phase Rev	3228	—	—	051
27	Over kVA Demand	Over kVA Dmd	2181	kVA	F	011
28	Over kW Demand	Over kW Dmd	2151	kW	F	011
29	Over kVAR Demand	Over kVAR Dmd	2166	kVAR	F	011
30	Over Frequency	Over Freq	1180	Hundredths of Hertz	—	010
31	Under Frequency	Under Freq	1180	Hundredths of Hertz	—	020
32	Lagging true power factor	Lag True PF	1163	Thousandths	—	055
33	Leading true power factor	Lead True PF	1163	Thousandths	—	054
34	Lagging displacement power factor	Lag Disp PF	1171	Thousandths	—	055
35	Leading displacement power factor	Lead Disp PF	1171	Thousandths	—	054
36	Over Current Demand Phase A	Over Ia Dmd	1961	Amperes	A	010
37	Over Current Demand Phase B	Over Ib Dmd	1971	Amperes	A	010
38	Over Current Demand Phase C	Over Ic Dmd	1981	Amperes	A	010
39	Over THD Voltage A-N	Over THD Van	1207	Tenths %	—	010
40	Over THD Voltage B-N	Over THD Vbn	1208	Tenths %	—	010
41	Over THD Voltage C-N	Over THD Vcn	1209	Tenths %	—	010
42	Over THD Voltage A-B	Over THD Vab	1211	Tenths %	—	010

① Alarm Types are described in Table 6-4 on page 90.

Table 6–3: List of Default Alarms by Alarm Number

Alarm Number	Alarm Description	Abbreviated Display Name	Test Register	Units	Scale Group	Alarm Type ①
43	Over THD Voltage B–C	Over THD Vbc	1212	Tenths %	—	010
44	Over THD Voltage C–A	Over THD Vca	1213	Tenths %	—	010
45-80	Reserved for custom alarms.	—	—	—	—	—
High Speed Alarms (100 ms)						
01	Over Current A	Over Ia HS	1,000	Amperes	A	010
02	Over Current B	Over Ib HS	1001	Amperes	A	010
03	Over Current C	Over Ic HS	1002	Amperes	A	010
04	Over Current N	Over In HS	1003	Amperes	B	010
05	Over Current G	Over Ig HS	1004	Amperes	C	010
06	Over Voltage A–N	Over Van HS	1024	Volts	D	010
07	Over Voltage B–N	Over Vbn HS	1025	Volts	D	010
08	Over Voltage C–N	Over Vcn HS	1026	Volts	D	010
09	Over Voltage A-B	Over Vab HS	1020	Volts	D	010
10	Over Voltage B-C	Over Vbc HS	1021	Volts	D	010
11	Over Voltage C-A	Over Vca HS	1022	Volts	D	010
12	Reserved for custom alarms					
13	Under Voltage A–N	Under Van HS	1024	Volts	D	020
14	Under Voltage B–N	Under Vbn HS	1025	Volts	D	020
15	Under Voltage C–N	Under Vcn HS	1026	Volts	D	020
16	Under Voltage A-B	Under Vab HS	1020	Volts	D	020
17	Under Voltage B–C	Under Vbc HS	1021	Volts	D	020
18	Under Voltage C–A	Under Vca HS	1022	Volts	D	020
19-20	Reserved for custom alarms	—	—	—	—	—
Disturbance Monitoring (1/2 Cycle) (CM3350 only)						
01	Voltage Swell A	Swell Van	4	Volts	D	080
02	Voltage Swell B	Swell Vbn	5	Volts	D	080
03	Voltage Swell C	Swell Vcn	6	Volts	D	080
04	Reserved for custom alarms					
05	Voltage Swell A–B	Swell Vab	1	Volts	D	080
06	Voltage Swell B–C	Swell Vbc	2	Volts	D	080
07	Voltage Swell C–A	Swell Vca	3	Volts	D	080
08	Voltage Sag A–N	Sag Van	4	Volts	D	090
09	Voltage Sag B–N	Sag Vbn	5	Volts	D	090
10	Voltage Sag C–N	Sag Vcn	6	Volts	D	090
11	Voltage Sag A–B	Sag Vab	1	Volts	D	090
12	Voltage Sag B–C	Sag Vbc	2	Volts	D	090
13	Voltage Sag C–A	Sag Vca	3	Volts	D	090
14	Current Swell A	Swell Ia	8	Amperes	A	080
15	Current Swell B	Swell Ib	9	Amperes	A	080
16	Current Swell C	Swell Ic	10	Amperes	A	080
17	Current Swell N	Swell In	11	Amperes	B	080
18	Current Sag A	Sag Ia	8	Amperes	A	090
19	Current Sag B	Sag Ib	9	Amperes	A	090
20	Current Sag C	Sag Ic	10	Amperes	A	090

① Alarm Types are described in Table 6–4 on page 90.

Table 6–3: List of Default Alarms by Alarm Number

Alarm Number	Alarm Description	Abbreviated Display Name	Test Register	Units	Scale Group	Alarm Type ①
Digital						
01	End of incremental energy interval	End Inc Enr Int	N/A	—	—	070
02	End of power demand interval	End Power Dmd Int	N/A	—	—	070
03	End of 1-second update cycle	End 1s Cyc	N/A	—	—	070
04	End of 100ms update cycle	End 100ms Cyc	N/A	—	—	070
05	Power up/Reset	Pwr Up/Reset	N/A	—	—	070
06-40	Reserved for custom alarms	—	—	—	—	—

① Alarm Types are described in Table 6–4 on page 90.

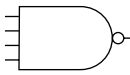
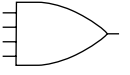

Table 6–4: Alarm Types

Type	Description	Operation
Standard Speed		
010	Over Value Alarm	If the test register value exceeds the setpoint long enough to satisfy the pickup delay period, the alarm condition will be true. When the value in the test register falls below the dropout setpoint long enough to satisfy the dropout delay period, the alarm will dropout. Pickup and dropout setpoints are positive, delays are in seconds.
011	Over Power Alarm	If the absolute value in the test register exceeds the setpoint long enough to satisfy the pickup delay period, the alarm condition will be true. When the value in the test register falls below the dropout setpoint long enough to satisfy the dropout delay period, the alarm will dropout. Pickup and dropout setpoints are positive, delays are in seconds.
012	Over Reverse Power Alarm	If the absolute value in the test register exceeds the setpoint long enough to satisfy the pickup delay period, the alarm condition will be true. When the value in the test register falls below the dropout setpoint long enough to satisfy the dropout delay period, the alarm will dropout. This alarm will only hold true for reverse power conditions. Positive power values will not cause the alarm to occur. Pickup and dropout setpoints are positive, delays are in seconds.
020	Under Value Alarm	If the test register value is below the setpoint long enough to satisfy the pickup delay period, the alarm condition will be true. When the value in the test register rises above the dropout setpoint long enough to satisfy the dropout delay period, the alarm will dropout. Pickup and dropout setpoints are positive, delays are in seconds.
021	Under Power Alarm	If the absolute value in the test register is below the setpoint long enough to satisfy the pickup delay period, the alarm condition will be true. When the value in the test register rises above the dropout setpoint long enough to satisfy the dropout delay period, the alarm will dropout. Pickup and dropout setpoints are positive, delays are in seconds.
051	Phase Reversal	The phase reversal alarm will occur whenever the phase voltage waveform rotation differs from the default phase rotation. The ABC phase rotation is assumed to be normal. If a CBA phase rotation is normal, the user should reprogram the circuit monitor's phase rotation ABC to CBA phase rotation. The pickup and dropout setpoints and delays for phase reversal do not apply.
052	Phase Loss, Voltage	The phase loss voltage alarm will occur when any one or two phase voltages (but not all) fall to the pickup value and remain at or below the pickup value long enough to satisfy the specified pickup delay. When all of the phases remain at or above the dropout value for the dropout delay period, or when all of the phases drop below the specified phase loss pickup value, the alarm will dropout. Pickup and dropout setpoints are positive, delays are in seconds.
053	Phase Loss, Current	The phase loss current alarm will occur when any one or two phase currents (but not all) fall to the pickup value and remain at or below the pickup value long enough to satisfy the specified pickup delay. When all of the phases remain at or above the dropout value for the dropout delay period, or when all of the phases drop below the specified phase loss pickup value, the alarm will dropout. Pickup and dropout setpoints are positive, delays are in seconds.

Table 6–4: Alarm Types

Type	Description	Operation
054	Leading Power Factor	The leading power factor alarm will occur when the test register value becomes more leading than the pickup setpoint (such as closer to 0.010) and remains more leading long enough to satisfy the pickup delay period. When the value becomes equal to or less leading than the dropout setpoint, that is 1.000, and remains less leading for the dropout delay period, the alarm will dropout. Both the pickup setpoint and the dropout setpoint must be positive values representing leading power factor. Enter setpoints as integer values representing power factor in thousandths. For example, to define a dropout setpoint of 0.5, enter 500. Delays are in seconds.
055	Lagging Power Factor	The lagging power factor alarm will occur when the test register value becomes more lagging than the pickup setpoint (such as closer to –0.010) and remains more lagging long enough to satisfy the pickup delay period. When the value becomes equal to or less lagging than the dropout setpoint, that is 1.000, and remains less lagging for the dropout delay period, the alarm will dropout. Both the pickup setpoint and the dropout setpoint must be positive values representing lagging power factor. Enter setpoints as integer values representing power factor in thousandths. For example, to define a dropout setpoint of –0.5, enter 500. Delays are in seconds.
High Speed		
010	Over Value Alarm	If the test register value exceeds the setpoint long enough to satisfy the pickup delay period, the alarm condition will be true. When the value in the test register falls below the dropout setpoint long enough to satisfy the dropout delay period, the alarm will dropout. Pickup and dropout setpoints are positive, delays are in hundreds of milliseconds.
011	Over Power Alarm	If the absolute value in the test register exceeds the setpoint long enough to satisfy the pickup delay period, the alarm condition will be true. When the value in the test register falls below the dropout setpoint long enough to satisfy the dropout delay period, the alarm will dropout. Pickup and dropout setpoints are positive, delays are in hundreds of milliseconds.
012	Over Reverse Power Alarm	If the absolute value in the test register exceeds the setpoint long enough to satisfy the pickup delay period, the alarm condition will be true. When the value in the test register falls below the dropout setpoint long enough to satisfy the dropout delay period, the alarm will dropout. This alarm will only hold true for reverse power conditions. Positive power values will not cause the alarm to occur. Pickup and dropout setpoints are positive, delays are in hundreds of milliseconds.
020	Under Value Alarm	If the test register value is below the setpoint long enough to satisfy the pickup delay period, the alarm condition will be true. When the value in the test register rises above the dropout setpoint long enough to satisfy the dropout delay period, the alarm will dropout. Pickup and dropout setpoints are positive, delays are in hundreds of milliseconds.
021	Under Power Alarm	If the absolute value in the test register is below the setpoint long enough to satisfy the pickup delay period, the alarm condition will be true. When the value in the test register rises above the dropout setpoint long enough to satisfy the dropout delay period, the alarm will dropout. Pickup and dropout setpoints are positive, delays are in hundreds of milliseconds.
051	Phase Reversal	The phase reversal alarm will occur when ever the phase voltage waveform rotation differs from the default phase rotation. The ABC phase rotation is assumed to be normal. If a CBA normal phase rotation is normal, the user should reprogram the circuit monitor's phase rotation ABC to CBA phase rotation. The pickup and dropout setpoints and delays for phase reversal do no apply.
052	Phase Loss, Voltage	The phase loss voltage alarm will occur when any one or two phase voltages (but not all) fall to the pickup value and remain at or below the pickup value long enough to satisfy the specified pickup delay. When all of the phases remain at or above the dropout value for the dropout delay period, or when all of the phases drop below the specified phase loss pickup value, the alarm will dropout. Pickup and dropout setpoints are positive, delays are in hundreds of milliseconds.
053	Phase Loss, Current	The phase loss current alarm will occur when any one or two phase currents (but not all) fall to the pickup value and remain at or below the pickup value long enough to satisfy the specified pickup delay. When all of the phases remain at or above the dropout value for the dropout delay period, or when all of the phases drop below the specified phase loss pickup value, the alarm will dropout. Pickup and dropout setpoints are positive, delays are in hundreds of milliseconds.

Table 6–4: Alarm Types

Type	Description	Operation
054	Leading Power Factor	The leading power factor alarm will occur when the test register value becomes more leading than the pickup setpoint (closer to 0.010) and remains more leading long enough to satisfy the pickup delay period. When the value becomes equal to or less leading than the dropout setpoint, that is 1.000, and remains less leading for the dropout delay period, the alarm will dropout. Both the pickup setpoint and the dropout setpoint must be positive values representing leading power factor. Enter setpoints as integer values representing power factor in thousandths. For example, to define a dropout setpoint of 0.5, enter 500. Delays are in hundreds of milliseconds.
055	Lagging Power Factor	The lagging power factor alarm will occur when the test register value becomes more lagging than the pickup setpoint (closer to –0.010) and remains more lagging long enough to satisfy the pickup delay period. When the value becomes equal to or less lagging than the dropout setpoint, that is 1.000 and remains less lagging for the dropout delay period, the alarm will dropout. Both the pickup setpoint and the dropout setpoint must be positive values representing lagging power factor. Enter setpoints as integer values representing power factor in thousandths. For example, to define a dropout setpoint of –0.5, enter 500. Delays are in hundreds of milliseconds.
Disturbance (CM3350 only)		
080	Voltage/Current Swell	The voltage and current swell alarms will occur whenever the continuous rms calculation is above the pickup setpoint and remains above the pickup setpoint for the specified number of cycles. When the continuous rms calculations fall below the dropout setpoint and remain below the setpoint for the specified number of cycles, the alarm will dropout. Pickup and dropout setpoints are positive and delays are in cycles.
090	Voltage/Current Sag	The voltage and current sag alarms will occur whenever the continuous rms calculation is below the pickup setpoint and remains below the pickup setpoint for the specified number of cycles. When the continuous rms calculations rise above the dropout setpoint and remain above the setpoint for the specified number of cycles, the alarm will drop out. Pickup and dropout setpoints are positive and delays are in cycles.
Digital		
060	Digital Input On	The digital input transition alarms will occur whenever the digital input changes from off to on. The alarm will dropout when the digital input changes back to off from on. The pickup and dropout setpoints and delays do not apply.
061	Digital Input Off	The digital input transition alarms will occur whenever the digital input changes from on to off. The alarm will dropout when the digital input changes back to on from off. The pickup and dropout setpoints and delays do not apply.
070	Unary	This is a internal signal from the circuit monitor and can be used, for example, to alarm at the end of an interval or when the circuit monitor is reset. The pickup and dropout delays do not apply.
Boolean		
100	Logic AND 	The AND alarm will occur when <i>all</i> of the combined enabled alarms are true (up to 4). The alarm will dropout when <i>any</i> of the enabled alarms drops out.
101	Logic NAND 	The NAND alarm will occur when <i>any, but not all, or none</i> of the combined enabled alarms are true. The alarm will dropout when <i>all</i> of the enabled alarms drop out, or <i>all</i> are true.
102	Logic OR 	The OR alarm will occur when <i>any</i> of the combined enabled alarms are true (up to 4). The alarm will dropout when <i>all</i> of the enabled alarms are <i>false</i> .
103	Logic NOR 	The NOR alarm will occur when <i>none</i> of the combined enabled alarms are true (up to 4). The alarm will dropout when <i>any</i> of the enabled alarms are <i>true</i> .
104	Logic XOR 	The XOR alarm will occur when <i>only one</i> of the combined enabled alarms is true (up to 4). The alarm will dropout when <i>the enabled alarm drops out</i> or when more than one alarm becomes <i>true</i> .

CHAPTER 7—LOGGING

This chapter briefly describes the following logs of the circuit monitor:

- Alarm log
- User-defined data logs
- Min/Max log and Interval Min/Max/Average log
- Maintenance log

Logs are files stored in the nonvolatile memory of circuit monitor and are referred to as “onboard logs.” Use SMS to set up and view all the logs. See the SMS online help for information about working with the circuit monitor’s onboard logs. Waveform captures and the 100-ms rms event recording are not logs, but the information is also saved in the circuit monitor’s memory. See “Memory Allocation” on page 98 for information about shared memory in the circuit monitor. For information about default circuit monitor settings, see “Factory Defaults” in the installation manual.

CHAPTER CONTENTS

CHAPTER CONTENTS	93
ALARM LOG	94
Alarm Log Storage	94
DATA LOGS	94
Alarm-Driven Data Log Entries	95
Organizing Data Log Files	95
Data Log Storage	95
MIN/MAX LOGS	96
Min/Max Log	96
Interval Min/Max/Average Log	96
Interval Min/Max/Average Log Storage	97
MAINTENANCE LOG	97
MEMORY ALLOCATION	98

ALARM LOG

Using SMS, you can set up the circuit monitor to log the occurrence of any alarm condition. Each time an alarm occurs it is entered into the alarm log. The alarm log in the circuit monitor stores the pickup and dropout points of alarms along with the date and time associated with these alarms. You select whether the alarm log saves data as first-in-first-out (FIFO) or fill and hold. You can also view and save the alarm log to disk, and reset the alarm log to clear the data out of the circuit monitor's memory.

Alarm Log Storage

The circuit monitor stores alarm log data in nonvolatile memory. You define the size of the alarm log (the maximum number of events). When determining the maximum number of events, consider the circuit monitor's total storage capacity. See "Memory Allocation" on page 98 for additional memory considerations.

DATA LOGS

The circuit monitor records meter readings at regularly scheduled intervals and stores the data in up to 14 independent data log files in its memory. Some data log files are preconfigured at the factory. You can accept the preconfigured data logs or change them to meet your specific needs. You can set up each data log to store the following information:

- Timed Interval—1 second to 24 hours (how often the values are logged)
- First-In-First-Out (FIFO) or Fill and Hold
- Values to be logged—up to 96 registers along with the date and time of each log entry

Use SMS to clear each data log file, independently of the others, from the circuit monitor's memory. For instructions on setting up and clearing data log files, refer to the SMS online help file.

Alarm-Driven Data Log Entries

The circuit monitor can detect over 100 alarm conditions, including over/under conditions, digital input changes, phase unbalance conditions, and more. (See **Chapter 6—Alarms** on page 77 for more information.) Use SMS to assign each alarm condition one or more tasks, including forcing data log entries into one or more data log files.

For example, assume that you've defined 14 data log files. Using SMS, you could select an alarm condition such as "Overcurrent Phase A" and set up the circuit monitor to force data log entries into any of the 14 log files each time the alarm condition occurs.

Organizing Data Log Files

You can organize data log files in many ways. One possible way is to organize log files according to the logging interval. You might also define a log file for entries forced by alarm conditions. For example, you could set up four data log files as follows:

Data Log 5: Log voltage every minute. Make the file large enough to hold 60 entries so that you could look back over the last hour's voltage readings.

Data Log 6: Log voltage, current, and power hourly for a historical record over a longer period.

Data Log 7: Log energy once every day. Make the file large enough to hold 31 entries so that you could look back over the last month and see daily energy use.

Data Log 8: Report by exception. The report by exception file contains data log entries that are forced by the occurrence of an alarm condition. See the previous section "Alarm-Driven Data Log Entries" for more information.

NOTE: The same data log file can support both scheduled and alarm-driven entries.

Data Log Storage

Each defined data log file entry stores a date and time and requires some additional overhead. To minimize storage space occupied by dates, times, and file overhead, use a few log files that log many values, as opposed to many log files that store only a few values each.

Consider that storage space is also affected by how many data log files you use (up to 14) and how many registers are logged in each entry (up to 96) for each data log file. See "Memory Allocation" on page 98 for additional storage considerations.

MIN/MAX LOGS

There are two Min/Max logs:

- Min/Max log
- Interval Min/Max/Average log

Min/Max Log

When any real-time reading reaches its highest or lowest value, the circuit monitor saves the value in the Min/Max log. You can use SMS to view and reset this log. For instructions, refer to the SMS online help. You can also view the min/max values from the display. From the Main Menu, select Min/Max and then select the value you'd like to view, such as amperes, volts, or frequency. See "Viewing Minimum and Maximum Values from the Min/Max Menu" on page 38 in this manual for detailed instructions. The Min/Max log cannot be customized.

Interval Min/Max/Average Log

In addition to the Min/Max log, the circuit monitor has a Min/Max/Average log. The Min/Max/Average log stores 23 quantities, which are listed below. At each interval, the circuit monitor records a minimum, a maximum, and an average value for each quantity. It also records the date and time for each interval along with the date and time for each minimum and maximum value within the interval. For example, every hour the default log will log the minimum voltage for phase A over the last hour, the maximum voltage for phase A over the last hour, and the average voltage for phase A over the last hour. All 23 values are preconfigured with a default interval of 60 minutes, but you can reset the interval from 1 to 1440 minutes. To setup, view, and reset the Min/Max/Average log using SMS, see "Reading and Writing Registers" in the SMS online help. The following values are logged into the Min/Max/Average log:

- Voltage Phase A–B
- Voltage Phase B–C
- Voltage Phase C–A
- Current Phase A
- Current Phase B
- Current Phase C
- Current Phase N
- Current Phase G
- kW 3-Phase Average
- kVAR 3-Phase Average
- kVA 3-Phase Average
- kW Demand 3-Phase Average
- kVAR Demand 3-Phase Average
- kVA Demand 3-Phase Average
- THD Voltage A–N
- THD Voltage B–N
- THD Voltage C–N
- THD Voltage A–B
- THD Voltage B–C
- THD Voltage C–A
- True Power Factor 3-Phase Total
- Displacement Power Factor 3-Phase Total

Interval Min/Max/Average Log Storage

When determining storage space among the logs, consider that storage space is affected by how often the circuit monitor is logging min/max/average values and how many entries are stored.

MAINTENANCE LOG

The circuit monitor stores a maintenance log in nonvolatile memory. Table 7–1 describes the values stored in the maintenance log. These values are cumulative over the life of the circuit monitor and cannot be reset.

Use SMS to view the maintenance log. Refer to the SMS online help for instructions.

Table 7–1: Values Stored in Maintenance Log

Value Stored	Description
Number of Demand Resets	Number of times demand values have been reset.
Number of Energy Resets	Number of times energy values have been reset.
Number of Min/Max Resets	Number of times min/max values have been reset.
Number of Output Operations	Number of times a digital output has operated. This value is stored for each digital output.
Number of Power Losses	Number of times circuit monitor has lost control power.
Number of Firmware Downloads	Number of times new firmware has been downloaded to the circuit monitor over communications.
Number of I/R Comms Sessions	Number of times the I/R communications port has been used. (Available only with VFD display.)
Highest Temperature Monitored	Highest temperature reached inside the circuit monitor.
Lowest Temperature Monitored	Lowest temperature reached inside the circuit monitor.
Number of GPS time syncs	Number of syncs received from the global positioning satellite transmitter.
Number of option card changes	Number of times the option card has been changed. Stored for both option card slots.
Number of times KYZ pulse output overdriven	Number of times the KYZ pulse output is overdriven
Number of input metering accumulation resets	Number of times input pulse demand metering has been reset.

MEMORY ALLOCATION

The circuit monitor's standard, nonvolatile memory is 8MB.

When using SMS to set up a circuit monitor, you must allocate the total data storage capacity between the following logs and recorded information:

- Alarm log
- Steady-state waveform capture
- Disturbance waveform capture
- 100-ms rms event recording (CM3350)
- Up to 14 data logs
- Min/Max/Average log

In addition, the choices you make for the items listed below directly affect the amount of memory used:

- The number of data log files (1 to 14)
- The registers logged in each entry (1 to 96), for each data log file.
- The maximum number of entries in each data log file.
- The maximum number of events in the alarm log file.
- The maximum number of waveform captures in each of the waveform capture files. Consider that you set the maximum number for two different waveform captures: steady-state, and disturbance waveform (cycles) plus a 100 ms rms event recording.

The number you enter for each of the above items depends on the amount of the memory that is still available, and the available memory depends on the numbers you've already assigned to the other items.

With 8 MB of memory, it is unlikely that you will use all the circuit monitor's memory, even if you use all 14 data logs and the other recording features. However, it is important to understand that memory is shared by the alarm logs, data logs, and waveform captures. Figure 7–1 on the left shows how the memory might be allocated.

In Figure 7–1, the user has set up disturbance waveform, a 100 ms event recording, an alarm log, and three data logs (two small logs, and one larger log). Of the total available nonvolatile memory, about 25% is still available. If the user decided to add a fourth data log file, the file could be no larger than the space still available—25% of the circuit monitor's total storage capacity. If the fourth file had to be larger than the space still available, the user would have to reduce the size of one of the other files to free up the needed space.

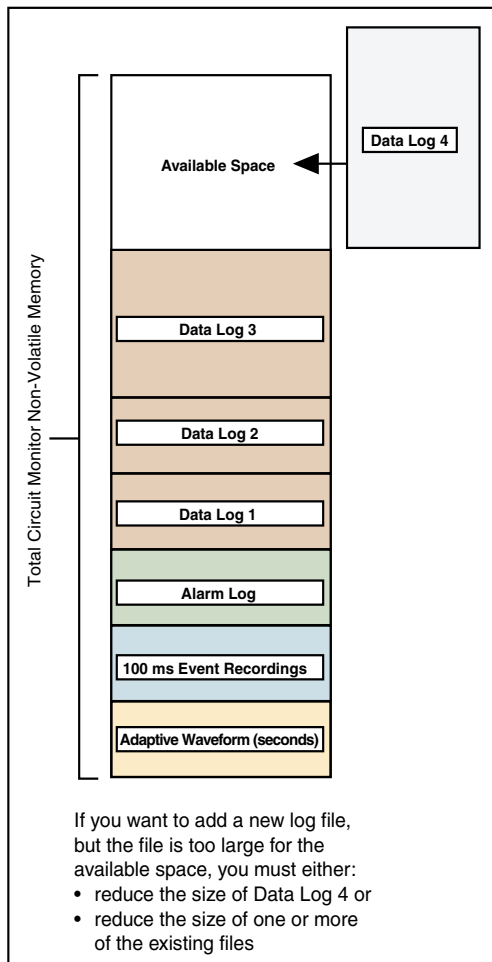

Figure 7–1: Memory allocation example

SMS displays the memory allocation statistics in the OnBoard Files dialog box shown in Figure 7–2. Color blocks on the bar show the space devoted to each type of log file, while black indicates memory still available. For instructions on setting up log files using SMS, refer to SMS online help file included with the software.

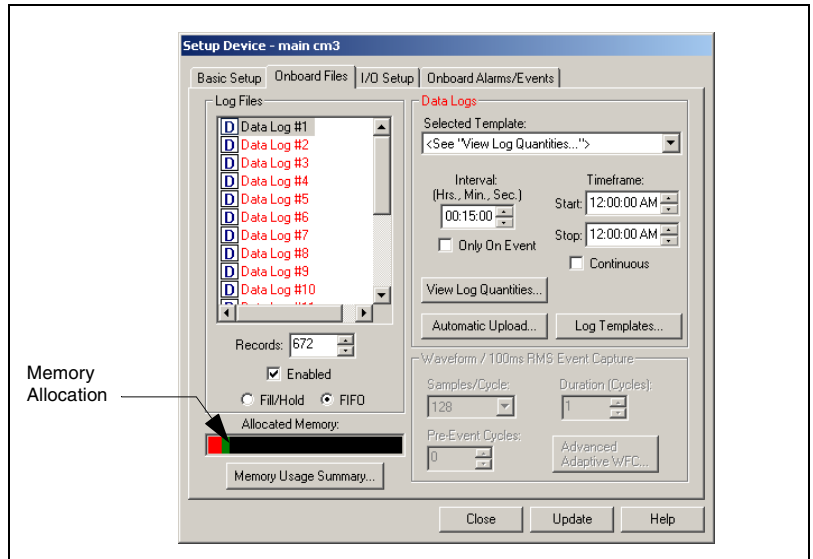

Figure 7–2: Memory allocation in SMS

CHAPTER 8—WAVEFORM AND EVENT CAPTURE

This chapter explains the waveform and event capture capabilities of the circuit monitor.

CHAPTER CONTENTS

CHAPTER CONTENTS	101
TYPES OF WAVEFORM CAPTURES	102
Steady-state Waveform Capture	102
Initiating a Steady-state Waveform	102
Disturbance Waveform Capture	102
100MS RMS EVENT RECORDING (CM3350 ONLY)	103
SETTING UP THE CIRCUIT MONITOR FOR AUTOMATIC EVENT CAP- TURE	104
Setting Up Alarm-Triggered Event Capture	104
Setting Up Input-Triggered Event Capture	104
WAVEFORM STORAGE	104
HOW THE CIRCUIT MONITOR CAPTURES AN EVENT	105

TYPES OF WAVEFORM CAPTURES

Using waveform captures you can monitor power sags and swells that may be produced, for example, when an X-ray machine and an elevator are used at the same time, or more commonly, when lightning strikes the distribution system that feeds the facility. The system's alarms can be programmed to detect and record such fluctuations, enabling you to determine an appropriate strategy for corrective action.

Circuit monitors use a sophisticated, high-speed sampling technique to simultaneously sample up to 128 samples per cycle on all current and voltage channels. From this sampling, the circuit monitor saves waveform data into its memory. These waveform captures can be graphically displayed using SMS. Two types of event captures are available from all CM3000 series circuit monitors. They are triggered by an event such as a digital input transition or over/under condition. These event recordings help you understand what happened during an electrical event. Using event captures you can analyze power disturbances in detail, identify potential problems, and take corrective action. See **Chapter 9—Disturbance Monitoring (CM3350)** on page 107 for more about disturbance monitoring. The types of event captures are described in the sections that follow.

Steady-state Waveform Capture

The steady-state waveform capture can be initiated manually to analyze steady-state harmonics. This waveform provides information about individual harmonics, which SMS calculates through the 63rd harmonic. It also calculates total harmonic distortion (THD) and other power quality parameters. The waveform capture records one cycle at 128 samples per cycle simultaneously on all metered channels.

Initiating a Steady-state Waveform

Using SMS from a remote PC, initiate a steady-state waveform capture manually by selecting the circuit monitor and issuing the acquire command. SMS will automatically retrieve the waveform capture from the circuit monitor. You can display the waveform for all three phases, or zoom in on a single waveform, which includes a data block with extensive harmonic data. See the SMS online help for instructions.

Disturbance Waveform Capture

Use the disturbance waveform capture to record events that may occur within a short time span such as multiple sags or swells. The circuit monitor initiates a disturbance waveform capture automatically when an alarm condition occurs (if the alarm is set up to perform the waveform capture). The trigger may be from an external device such as a protective relay trip contact connected to a digital input or voltage sag alarm, or you can also initiate the waveform capture manually from SMS at any time.

In SMS, for the disturbance waveform capture, you select how many cycles and pre-event cycles the circuit monitor will capture. The waveform capture records at 128 samples per cycle.

See the SMS online help for instructions on setting up disturbance waveform captures.

100MS RMS EVENT RECORDING (CM3350 ONLY)

The 100ms rms event capture gives you a different view of an event by recording 100ms data for the amount of time you specify. Table 8–1 lists all the quantities captured. This type of event capture is useful for analyzing what happened during a motor start or recloser operation because it shows a long event without using a significant amount of memory. The circuit monitor initiates the event capture automatically when an alarm condition occurs, or an external device can also trigger the event capture. You select the duration of the event recording (up to 300 seconds) and the number of pre-event seconds (1–10) that the circuit monitor will capture.

Table 8–1: 100ms rms Quantities

Current
Per-Phase
Neutral ^①
Voltage
Line-to-Neutral, Per-Phase ^①
Line-to-Line, Per-Phase
Real Power
Per-Phase ^①
3-Phase Total
Reactive Power
Per-Phase ^①
3-Phase Total
Apparent Power
3-Phase Total
Power Factor (True)
3-Phase Total

^①4-wire systems only

SETTING UP THE CIRCUIT MONITOR FOR AUTOMATIC EVENT CAPTURE

There are two ways to set up the circuit monitor for automatic event capture:

- Use an alarm to trigger the waveform capture.
- Use an external trigger such as a relay.

This section provides an overview of the steps you perform in SMS to setup these event captures.

Setting Up Alarm-Triggered Event Capture

To set up the circuit monitor for automatic event capture, use SMS to perform the following steps:

NOTE: For detailed instructions, refer to the SMS online help.

1. Select the type of event capture (disturbance or 100ms) and set up the number of samples per cycle, pre-event cycles or seconds, and duration.
2. Select an alarm condition.
3. Define the pick up and dropout setpoints of the alarm, if applicable.
4. Select the automatic waveform capture option (Capture Waveform on Event).
5. Repeat these steps for the desired alarm conditions.

Setting Up Input-Triggered Event Capture

When the circuit monitor is connected to an external device such as a protective relay, the circuit monitor can capture and provide valuable information on short duration events such as voltage sags. The circuit monitor must be equipped with digital inputs on an IOC-44 Digital I/O Card.

To set up the circuit monitor for event capture triggered by an input, use SMS to perform the following steps:

NOTE: For detailed instructions, refer to the SMS online help.

1. Select the type of event capture (disturbance or 100ms) and set up the number of samples per cycle, pre-event cycles or seconds, and duration.
2. Create a digital alarm for the input if it is not already defined.
3. Select the alarm.
4. Choose the type of event recording you would like.

WAVEFORM STORAGE

The circuit monitor can store multiple captured waveforms in its nonvolatile memory. The number of waveforms that can be stored is based on the amount of memory that has been allocated to waveform capture. However, the maximum number of stored waveforms is eighty of each type. All stored waveform data is retained on power-loss.

HOW THE CIRCUIT MONITOR CAPTURES AN EVENT

When the circuit monitor senses the trigger—that is, when the digital input transitions from OFF to ON, or an alarm condition is met—the circuit monitor transfers the cycle data from its data buffer into the memory allocated for event captures. The number of cycles or seconds it saves depends on the number of cycles or seconds you selected.

Figure 8–1 shows an event capture. In this example, the circuit monitor was monitoring a constant load when a utility fault occurred, followed by a return to normal.

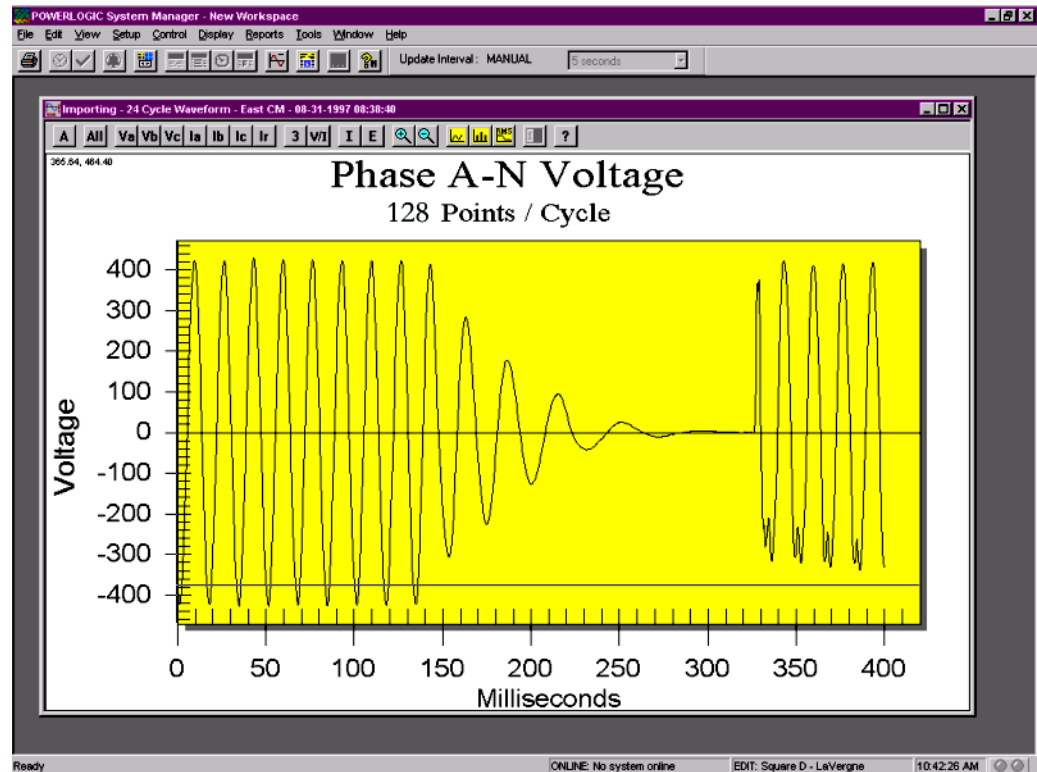

Figure 8–1: Event capture initiated from a high-speed input

CHAPTER 9—DISTURBANCE MONITORING (CM3350)

This chapter gives you background information about disturbance monitoring and describes how to use the circuit monitor to continuously monitor for disturbances on the current and voltage inputs. It also provides an overview of using SMS to gather data when a disturbance event occurs.

CHAPTER CONTENTS

CHAPTER CONTENTS	107
ABOUT DISTURBANCE MONITORING	108
CAPABILITIES OF THE CIRCUIT MONITOR DURING AN EVENT ...	111
USING THE CIRCUIT MONITOR WITH SMS TO PERFORM DISTURBANCE MONITORING	112
UNDERSTANDING THE ALARM LOG	112

ABOUT DISTURBANCE MONITORING

Momentary voltage disturbances are an increasing concern for industrial plants, hospitals, data centers, and other commercial facilities because modern equipment used in those facilities tends to be more sensitive to voltage sags, swells, and momentary interruptions. The circuit monitor can detect these events by continuously monitoring and recording current and voltage information on all metered channels. Using this information, you can diagnose equipment problems resulting from voltage sags or swells and identify areas of vulnerability, enabling you to take corrective action.

The interruption of an industrial process because of an abnormal voltage condition can result in substantial costs, which manifest themselves in many ways:

- labor costs for cleanup and restart
- lost productivity
- damaged product or reduced product quality
- delivery delays and user dissatisfaction

The entire process can depend on the sensitivity of a single piece of equipment. Relays, contactors, adjustable speed drives, programmable controllers, PCs, and data communication networks are all susceptible to transient and short-duration power problems. After the electrical system is interrupted or shut down, determining the cause may be difficult.

Several types of voltage disturbances are possible, each potentially having a different origin and requiring a separate solution. A momentary interruption occurs when a protective device interrupts the circuit that feeds a facility. Swells and overvoltages can damage equipment or cause motors to overheat. Perhaps the biggest power quality problem is the momentary voltage sag caused by faults on remote circuits.

A voltage sag is a brief (1/4 cycle to 1 minute) decrease in rms voltage magnitude. A sag is typically caused by a remote fault somewhere on the power system, often initiated by a lightning strike. In Figure 9–1, the utility circuit breaker cleared the fault near plant D. The fault not only caused an interruption to plant D, but also resulted in voltage sags to plants A, B, and C.

NOTE: The CM3000 is able to detect sag and swell events less than 1/2 cycle duration. However, it may be impractical to have setpoints more sensitive than 10% for voltage and current fluctuations.

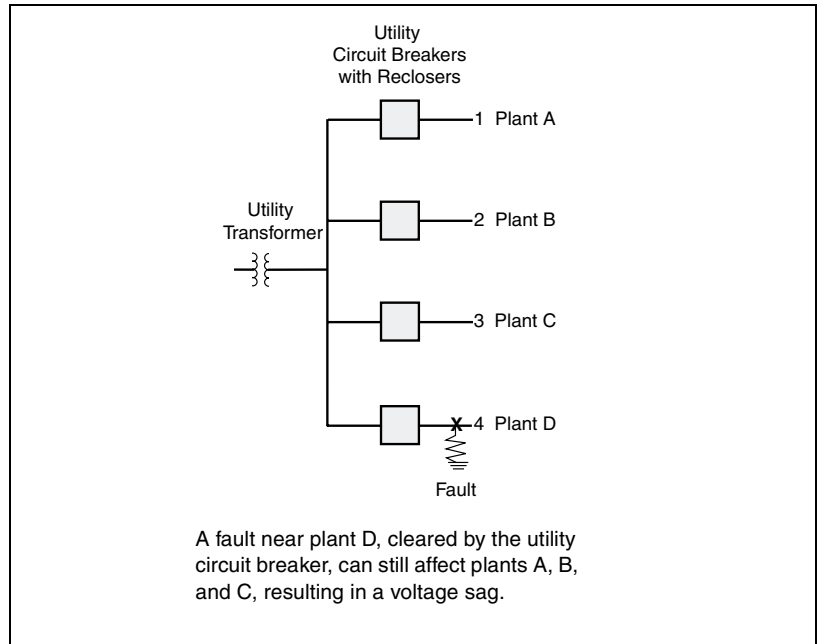

Figure 9–1: A fault can cause voltage sag on the whole system.

System voltage sags are much more numerous than interruptions, since a wider part of the distribution system is affected. And, if reclosers are operating, they may cause repeated sags. The circuit monitor can record recloser sequences, too. The waveform in Figure 9–2 shows the magnitude of a voltage sag, which persists until the remote fault is cleared.

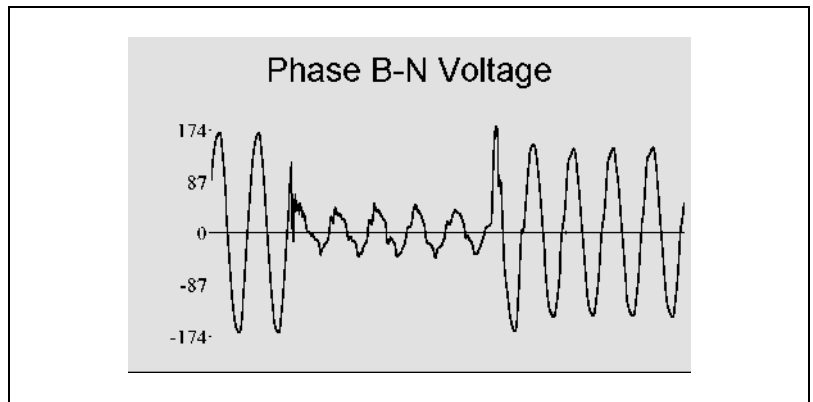

Figure 9–2: Waveform showing voltage sag, which was caused by a remote fault and lasted five cycles.

With the information obtained from the circuit monitor during a disturbance, you can solve disturbance-related problems, including the following:

- Obtain accurate measurement from your power system
 - Identify the number of sags, swells, or interruptions for evaluation
 - Determine the source (user or utility) of sags or swells
 - Accurately distinguish between sags and interruptions, with accurate recording of the time and date of the occurrence
 - Provide accurate data in equipment specification (ride-through, etc.)
- Determine equipment sensitivity
 - Compare equipment sensitivity of different brands (contactor dropout, drive sensitivity, etc.)
 - Diagnose mysterious events such as equipment failure, contactor dropout, computer glitches, etc.
 - Compare actual sensitivity of equipment to published standards
 - Use waveform capture to determine exact disturbance characteristics to compare with equipment sensitivity
 - Justify purchase of power conditioning equipment
 - Distinguish between equipment failures and power system related problems
- Develop disturbance prevention methods
 - Develop solutions to voltage sensitivity-based problems using actual data
- Work with the utility
 - Discuss protection practices with the serving utility and negotiate suitable changes to shorten the duration of potential sags (reduce interruption time delays on protective devices)
 - Work with the utility to provide alternate “stiffer” services (alternate design practices)

CAPABILITIES OF THE CIRCUIT MONITOR DURING AN EVENT

The circuit monitor calculates rms magnitudes, based on 128 data points per cycle, every 1/2 cycle. This ensures that even sub-cycle duration rms variations are not missed. Table 9–1 shows the capability of the circuit monitor to measure electromagnetic phenomena in a power system as defined in IEEE Recommended Practice for Monitoring Electric Power Quality (IEEE Standard 1159-95).

Table 9–1: Capability of the circuit monitor to measure electromagnetic phenomena

Categories	CM-3000
Short Duration Variations	
Instantaneous	✓
Momentary	✓
Temporary	✓
Long Duration Variations	✓
Voltage Imbalance	✓
Waveform Distortion	✓
Voltage Fluctuations	✓
Power Frequency Variations	✓

When the circuit monitor detects a sag or swell, it can perform the following actions:

- **Perform a waveform capture** with a resolution up to 128 samples per cycle on all channels of the metered current and voltage inputs. Two types of automatic event captures are possible: disturbance and 100 ms. See “Types of Waveform Captures” on page 102 in **Chapter 8—Waveform and Event Capture** for more about waveform and event captures. Use SMS to setup the event capture and retrieve the waveform.
- **Record the event in the alarm log.** When an event occurs, the circuit monitor updates the alarm log with an event date and time stamp with 1 millisecond resolution for a sag or swell pickup, and an rms magnitude corresponding to the most extreme value of the sag or swell during the event pickup delay. Also, the circuit monitor can record the sag or swell dropout in the alarm Log at the end of the disturbance. Information stored includes: a dropout time stamp with 1 millisecond resolution and a second rms magnitude corresponding to the most extreme value of the sag or swell. Use SMS to view the alarm log.
- **Force a data log entry** in up to 14 independent data logs. Use SMS to set up and view the data logs.
- **Operate any output relays** when the event is detected.
- **Indicate the alarm** on the display by flashing the alarm LED to show that a sag or swell event has occurred. From the circuit monitor’s display, a list of up to 10 of the previous alarms in the high priority log is available. You can also view the alarms in SMS.

USING THE CIRCUIT MONITOR WITH SMS TO PERFORM DISTURBANCE MONITORING

This section gives you an overview of the steps to set up the circuit monitor for disturbance monitoring. For detailed instructions, see the SMS online help. In SMS under Setup > Devices Routing, the Device Setup dialog box contains the tabs for setting up disturbance monitoring. After you have performed basic set up of the circuit monitor, perform three setup steps:

1. Define the storage space for the alarm log, waveform capture, and any forced data logs using the Onboard Files tab in SMS. This sets up the amount of circuit monitor memory that the logs and waveform capture will use.

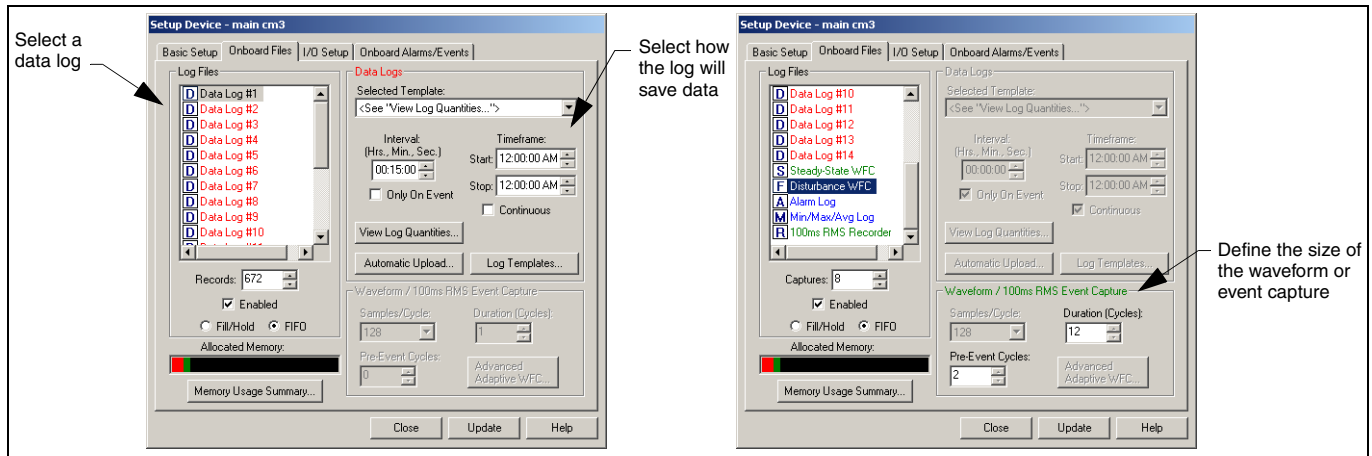

Figure 9-3: Onboard Files tab

2. Associate an alarm with data logs and waveform/event captures using the Onboard Alarms/Events tab.

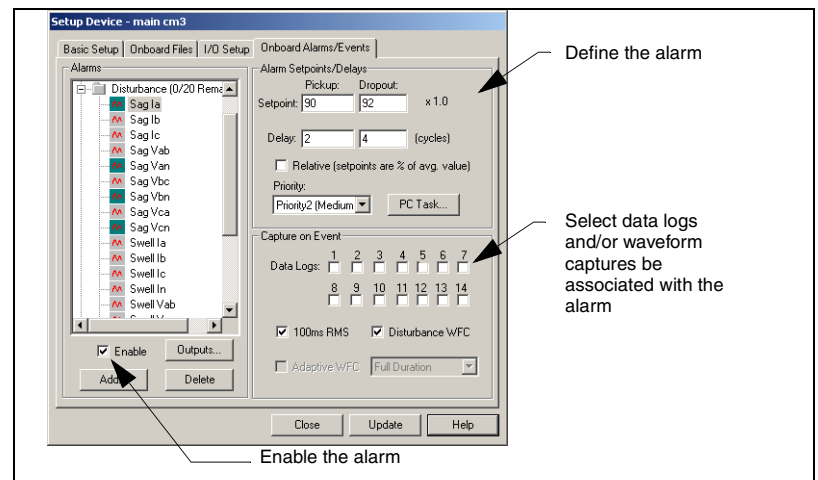

Figure 9-4: Onboard Alarms/Events tab

3. In addition, you can set up a relay to operate upon an event using the I/O tab in SMS.

UNDERSTANDING THE ALARM LOG

Pickups and dropouts of an event are logged into the onboard alarm log of the circuit monitor as separate entries. Figure 9-5 illustrates an alarm log entry sequence. In this example, two events are entered into the alarm log:

- Alarm Log Entry 1—The value stored in the alarm log at the end of the pickup delay is the furthest excursion from normal during the pickup delay period $t1$. This is calculated using 128 data point rms calculations.
- Alarm Log Entry 2—The value stored in the alarm log at the end of the dropout delay is the furthest excursion from normal during period $t2$ from the end of the pickup delay to the end of the dropout delay.

The time stamps for the pickup and dropout reflect the actual duration of these periods.

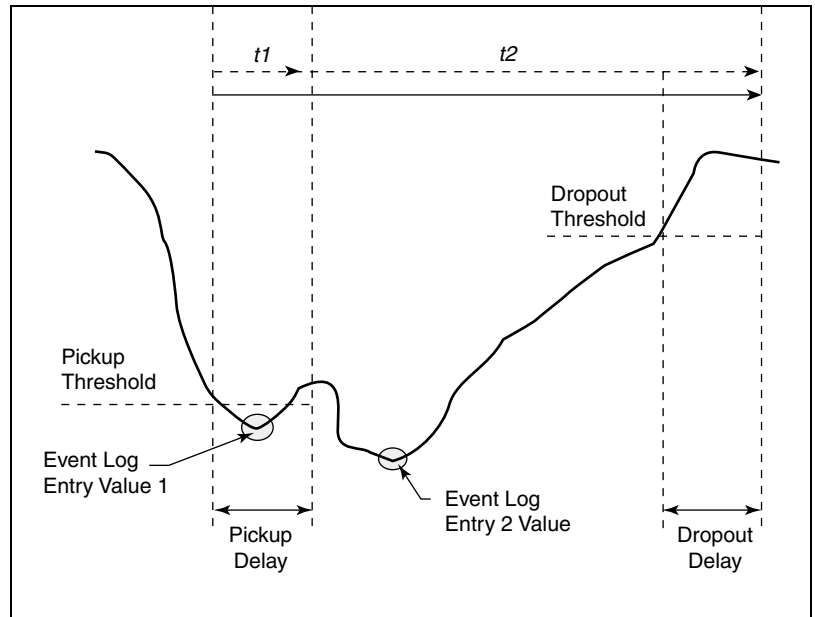

Figure 9-5: Event log entries example

Once the alarm has been recorded, you can view the alarm log in SMS. A sample alarm log entry is shown in Figure 9-6. See SMS online help for instructions on working with the alarm log.

Time	Device	Type	Function	Value	State	Level
03/14/2001 5:16:34.998 PM	CM3000 Office	0	Swell Ib	690	Voltage/Current Swell Dropout	3
03/14/2001 5:16:34.981 PM	CM3000 Office	0	Swell Ia	690	Voltage/Current Swell Dropout	2
03/14/2001 5:16:31.297 PM	CM3000 Office	0	Swell Ia	685	Voltage/Current Swell Pickup	2
03/14/2001 5:16:31.181 PM	CM3000 Office	0	Swell Ia	651	Voltage/Current Swell Dropout	2
03/14/2001 5:16:31.031 PM	CM3000 Office	0	Swell Ia	670	Voltage/Current Swell Pickup	2
03/14/2001 5:16:30.997 PM	CM3000 Office	0	Swell Ib	653	Voltage/Current Swell Pickup	3
03/14/2001 3:39:28.404 PM	CM3000 Office	0	Swell Ib	674	Voltage/Current Swell Dropout	3

Figure 9-6: Sample alarm log entry

CHAPTER 10—MAINTENANCE AND TROUBLESHOOTING

This chapter describes information related to maintenance of your circuit monitor.

CHAPTER CONTENTS

CHAPTER CONTENTS	115
CIRCUIT MONITOR MEMORY	117
IDENTIFYING THE FIRMWARE VERSION	118
VIEWING THE DISPLAY IN DIFFERENT LANGUAGES	118
GETTING TECHNICAL SUPPORT	118
TROUBLESHOOTING	119

The circuit monitor does not require regular maintenance, nor does it contain any user-serviceable parts. If the circuit monitor requires service, contact your local sales representative. Do not open the circuit monitor. Opening the circuit monitor voids the warranty.

⚠ DANGER

HAZARD OF ELECTRIC SHOCK, BURN, OR EXPLOSION

Do not attempt to service the circuit monitor. CT and PT inputs may contain hazardous currents and voltages. Only authorized service personnel from the manufacturer should service the circuit monitor.

Failure to follow this instruction will result in death or serious injury.

⚠ CAUTION

HAZARD OF EQUIPMENT DAMAGE

Do not perform a Dielectric (Hi-Pot) or Megger test on the circuit monitor. High voltage testing of the circuit monitor may damage the unit. Before performing Hi-Pot or Megger testing on any equipment in which the circuit monitor is installed, disconnect all input and output wires to the circuit monitor.

Failure to follow this instruction can result in injury or equipment damage.

CIRCUIT MONITOR MEMORY

The circuit monitor uses its nonvolatile memory (RAM) to retain all data and metering configuration values. Under the operating temperature range specified for the circuit monitor, this nonvolatile memory has an expected life of up to 100 years. The circuit monitor stores its data logs on a memory chip, which has a life expectancy of up to 20 years under the operating temperature range specified for the circuit monitor. The life of the circuit monitor's internal battery-backed clock is over 20 years at 25°C.

NOTE: Life expectancy is a function of operating conditions; this does not constitute any expressed or implied warranty.

IDENTIFYING THE FIRMWARE VERSION

You can upgrade the circuit monitor's firmware through any of these ports:

- RS-485 port
- Infrared port on the VFD display
- Ethernet communications card

To determine the firmware version of the circuit monitor's operating system from the remote display, do this:

From the main menu, select **Diagnostics > Meter Information**. The information about your meter displays on the Meter Information screen. Your screen may vary slightly.

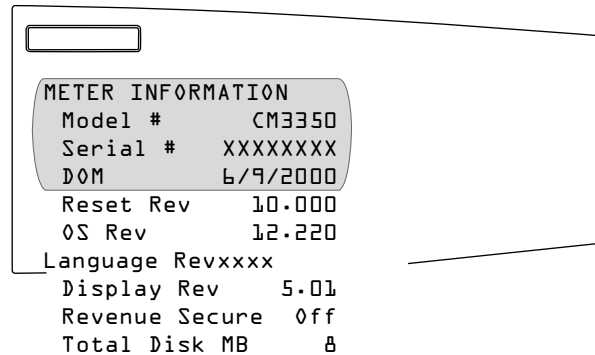

To determine the firmware version over the communication link, use SMS to perform a System Communications Test. The firmware version is listed in the firmware revision (F/W Revision) column.

VIEWING THE DISPLAY IN DIFFERENT LANGUAGES

The Series 3000 Circuit Monitor can be configured to display text in various languages. Language files are installed using the DLF-3000 software application. To obtain and use language files, refer to the DLF-3000 Version 3.0 or later documentation.

GETTING TECHNICAL SUPPORT

Please refer to the *Technical Support Contacts* provided in the circuit monitor shipping carton for a list of support phone numbers by country.

TROUBLESHOOTING

The information in Table 10–1 describes potential problems and their possible causes. It also describes checks you can perform or possible solutions for each. After referring to this table, if you cannot resolve the problem, contact the your local Square D/Schneider Electric sales representative for assistance.

DANGER

HAZARD OF ELECTRIC SHOCK, BURN, OR EXPLOSION

- This equipment must be installed and serviced only by qualified personnel.
- Qualified persons performing diagnostics or troubleshooting that require electrical conductors to be energized must comply with NFPA 70 E - Standard for Electrical Safety Requirements for Employee Workplaces and OSHA Standards - 29 CFR Part 1910 Subpart S - Electrical.
- Carefully inspect the work area for tools and objects that may have been left inside the equipment.
- Use caution while removing or installing panels so that they do not extend into the energized bus; avoid handling the panels, which could cause personal injury.

Failure to follow these instructions will result in death or serious injury.

Table 10–1: Troubleshooting

Potential Problem	Possible Cause	Possible Solution
The red maintenance LED is illuminated on the circuit monitor.	When the red maintenance LED is illuminated, it indicates a potential hardware or firmware problem in the circuit monitor.	When the red maintenance LED is illuminated, “Maintenance LED” is added to the menu under “Diagnostics.” Error messages display to indicate the reason the LED is illuminated. Note these error messages and call Technical Support or contact your local sales representative for assistance.
The green control power LED is not illuminated on the circuit monitor.	The circuit monitor is not receiving the necessary power.	Verify that the circuit monitor line (L) and neutral (N) terminals (terminals 25 and 27) are receiving the necessary power.
The display is blank after applying control power to the circuit monitor.	The display is not receiving the necessary power or communications signal from the circuit monitor.	Verify that the display cable is properly inserted into the connectors on the display and the circuit monitor.

Table 10–1: Troubleshooting

The data being displayed is inaccurate or not what you expect.	Circuit monitor is grounded incorrectly.	Verify that the circuit monitor is grounded as described in “Grounding the Circuit Monitor” in the installation manual.
	Incorrect setup values.	Check that the correct values have been entered for circuit monitor setup parameters (CT and PT ratings, System Type, Nominal Frequency, and so on). See “Setting Up the Metering Functions of the Circuit Monitor” on page 16 for setup instructions.
	Incorrect voltage inputs.	Check circuit monitor voltage input terminals (9, 10, 11, 12) to verify that adequate voltage is present.
	Circuit monitor is wired improperly.	Check that all CTs and PTs are connected correctly (proper polarity is observed) and that they are energized. Check shorting terminals. See “Wiring CTs, PTs, and Control Power to the Circuit Monitor” in the installation manual for wiring diagrams. Initiate a wiring check from the circuit monitor display.
Cannot communicate with circuit monitor from a remote personal computer.	Circuit monitor address is incorrect.	Check to see that the circuit monitor is correctly addressed. See “RS-485 and Infrared Port Communications Setup” on page 13 for instructions.
	Circuit monitor baud rate is incorrect.	Verify that the baud rate of the circuit monitor matches the baud rate of all other devices on its communications link. See “RS-485 and Infrared Port Communications Setup” on page 13 for instructions.
	Communications lines are improperly connected.	Verify the circuit monitor communications connections. Refer to Chapter 6—Communications Connections in the installation manual for instructions.
	Communications lines are improperly terminated.	Check to see that a multipoint communications terminator is properly installed. See “Terminating the Communications Link” in the installation manual for instructions.
	Incorrect route statement to circuit monitor.	Check the route statement. Refer to the SMS online help for instructions on defining route statements.

APPENDIX A—ABBREVIATED REGISTER LISTING

This appendix contains information about the registers of the circuit monitor.

CONTENTS

CONTENTS	121
ABOUT REGISTERS	121
HOW POWER FACTOR IS STORED IN THE REGISTER	122
HOW DATE AND TIME ARE STORED IN REGISTERS	123
REGISTER LISTING	124

ABOUT REGISTERS

The four tables in this appendix contain an abbreviated listing of circuit monitor registers:

- Table A-3 on page 124 identifies registers for these values:
 - Real-Time Metered Values (1 second)
 - Power Quality
 - Minimum Real-Time Meter Values
 - Maximum Real-Time Meter Values
 - Accumulated Energy Values
 - Demand Values
 - Phase Extremes
 - System Configuration
 - Metering Configuration
 - Communications
- Table A-4 on page 176 lists the register numbers related to the set up of inputs and outputs.
- Table A-5 on page 182 identifies the alarm position register numbers.
- Table A-6 on page 189 lists the registers used for the individual per-phase harmonic magnitudes and angles through the 63rd harmonic for all currents and voltages.

For registers defined in bits, the rightmost bit is referred to as bit 00. Figure A-1 shows how bits are organized in a register.

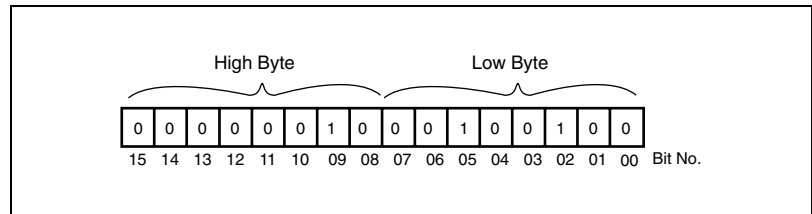

Figure A-1: Bits in a register

The circuit monitor registers can be used with MODBUS or JBUS protocols. Although the MODBUS protocol uses a zero-based register addressing convention and JBUS protocol uses a one-based register addressing convention, the circuit monitor automatically compensates for the MODBUS offset of one. Regard all registers as holding registers where a 30,000 or 40,000 offset can be used. For example, Current Phase A will reside in register 31,000 or 41,000 instead of 1,000 as listed in Table A-3 on page 124.

HOW POWER FACTOR IS STORED IN THE REGISTER

Each power factor value occupies one register. Power factor values are stored using signed magnitude notation (see Figure A-2 below). Bit number 15, the sign bit, indicates leading/lagging. A positive value (bit 15=0) always indicates leading. A negative value (bit 15=1) always indicates lagging. Bits 0-9 store a value in the range 0-1,000 decimal. For example the circuit monitor would return a leading power factor of 0.5 as 500. Divide by 1,000 to get a power factor in the range 0 to 1.000.

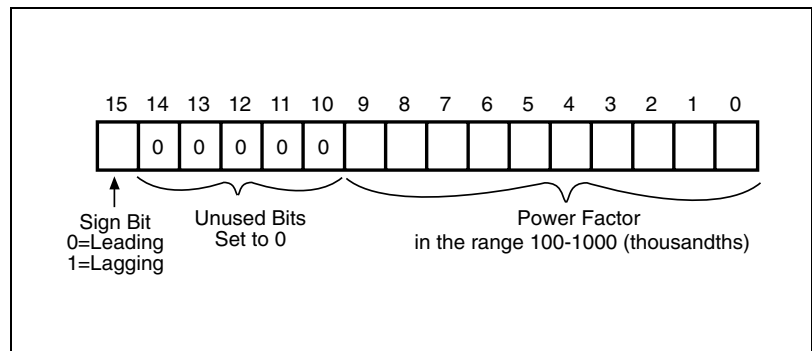

Figure A-2: Power factor register format

When the power factor is lagging, the circuit monitor returns a high negative value—for example, -31,794. This happens because bit 15=1 (for example, the binary equivalent of -31,794 is 1000001111001110). To get a value in the range 0 to 1,000, you need to mask bit 15. You do this by adding 32,768 to the value. An example will help clarify.

Assume that you read a power factor value of -31,794. Convert this to a power factor in the range 0 to 1.000, as follows:

$$-31,794 + 32,768 = 974$$

$$974/1,000 = .974 \text{ lagging power factor}$$

HOW DATE AND TIME ARE STORED IN REGISTERS

The date and time are stored in a four-register compressed format. Each of the four registers, such as registers 1810 to 1813, contain a high and low byte value to represent the date and time in hexadecimal. Table A–1 lists the register and the portion of the date or time it represents.

Table A–1:Date and Time Format

Register	Hi Byte	Lo Byte
Register 1	Month (1-12)	Day (1-31)
Register 2	Year (0-199)	Hour (0-23)
Register 3	Minute (0-59)	Second (0-59)
Register 4	Milliseconds	

For example, if the date was 01/25/00 at 11:06:59.122, the Hex value would be 0119, 640B, 063B, 007A. Breaking it down into bytes we have the following:

Table A–2:Date and Time Byte Example

Hexadecimal Value	Hi Byte	Lo Byte
0119	01 = month	19 = day
640B	64 = year	0B = hour
063B	06 = minute	3B = seconds
007A	007A = milliseconds	

REGISTER LISTING

Table A-3: Abbreviated Register List

Reg	Name	Size	Type	Access	NV	Scale	Units	Range	Notes
100 ms Real-Time Readings									
1000	Current, Phase A	1	Integer	RO	N	A	Amperes/Scale	0 – 32,767	RMS
1001	Current, Phase B	1	Integer	RO	N	A	Amperes/Scale	0 – 32,767	RMS
1002	Current, Phase C	1	Integer	RO	N	A	Amperes/Scale	0 – 32,767	RMS
1003	Current, Neutral	1	Integer	RO	N	B	Amperes/Scale	0 – 32,767 (-32,768 if N/A)	RMS 4-wire system only
1004	Current, Ground	1	Integer	RO	N	C	Amperes/Scale	0 – 32,767 (-32,768 if N/A)	RMS 4-wire system only
1005	Current, 3-Phase Average	1	Integer	RO	N	A	Amperes/Scale	0 – 32,767	Calculated mean of Phases A, B & C
1006	Current, Apparent RMS	1	Integer	RO	N	A	Amperes/Scale	0 – 32,767	Peak instantaneous current of Phase A, B or C divided by $\sqrt{2}$
1020	Voltage, A-B	1	Integer	RO	N	D	Volts/Scale	0 – 32,767	Fundamental RMS Voltage measured between A & B
1021	Voltage, B-C	1	Integer	RO	N	D	Volts/Scale	0 – 32,767	Fundamental RMS Voltage measured between B & C
1022	Voltage, C-A	1	Integer	RO	N	D	Volts/Scale	0 – 32,767	Fundamental RMS Voltage measured between C & A
1023	Voltage, L-L Average	1	Integer	RO	N	D	Volts/Scale	0 – 32,767	Fundamental RMS 3 Phase Average L-L Voltage
1024	Voltage, A-N	1	Integer	RO	N	D	Volts/Scale	0 – 32,767 (-32,768 if N/A)	Fundamental RMS Voltage measured between A & N 4-wire system only
1025	Voltage, B-N	1	Integer	RO	N	D	Volts/Scale	0 – 32,767 (-32,768 if N/A)	Fundamental RMS Voltage measured between B & N 4-wire system only
1026	Voltage, C-N	1	Integer	RO	N	D	Volts/Scale	0 – 32,767 (-32,768 if N/A)	Fundamental RMS Voltage measured between C & N 4-wire system only
1028	Voltage, L-N Average	1	Integer	RO	N	D	Volts/Scale	0 – 32,767 (-32,768 if N/A)	Fundamental RMS 3-Phase Average L-N Voltage 4-wire system only
1040	Real Power, Phase A	1	Integer	RO	N	F	kW/Scale	-32,767 – 32,767 (-32,768 if N/A)	Real Power (PA) 4-wire system only
1041	Real Power, Phase B	1	Integer	RO	N	F	kW/Scale	-32,767 – 32,767 (-32,768 if N/A)	Real Power (PB) 4-wire system only
1042	Real Power, Phase C	1	Integer	RO	N	F	kW/Scale	-32,767 – 32,767 (-32,768 if N/A)	Real Power (PC) 4-wire system only
1043	Real Power, Total	1	Integer	RO	N	F	kW/Scale	-32,767 – 32,767	4-wire system = PA+PB+PC 3 wire system = 3-Phase real power
1044	Reactive Power, Phase A	1	Integer	RO	N	F	kVAr/Scale	-32,767 – 32,767 (-32,768 if N/A)	Reactive Power (QA) 4-wire system only
1045	Reactive Power, Phase B	1	Integer	RO	N	F	kVAr/Scale	-32,767 – 32,767 (-32,768 if N/A)	Reactive Power (QB) 4-wire system only
1046	Reactive Power, Phase C	1	Integer	RO	N	F	kVAr/Scale	-32,767 – 32,767 (-32,768 if N/A)	Reactive Power (QC) 4-wire system only
1047	Reactive Power, Total	1	Integer	RO	N	F	kVAr/Scale	-32,767 – 32,767	4-wire system = QA+QB+QC 3 wire system = 3-Phase real power
1048	Apparent Power, Phase A	1	Integer	RO	N	F	kVA/Scale	-32,767 – 32,767 (-32,768 if N/A)	Apparent Power (SA) 4-wire system only

RO = Read only.
R/CW = Read configure writeable if in a setup session.
NV = Nonvolatile.
① See "How Power Factor is Stored in the Register" on page 122.
② See "How Date and Time Are Stored in Registers" on page 123.

Table A-3: Abbreviated Register List

Reg	Name	Size	Type	Access	NV	Scale	Units	Range	Notes
1049	Apparent Power, Phase B	1	Integer	RO	N	F	kVA/Scale	-32,767 – 32,767 (-32,768 if N/A)	Apparent Power (SB) 4-wire system only
1050	Apparent Power, Phase C	1	Integer	RO	N	F	kVA/Scale	-32,767 – 32,767 (-32,768 if N/A)	Apparent Power (SC) 4-wire system only
1051	Apparent Power, Total	1	Integer	RO	N	F	kVA/Scale	-32,767 – 32,767	4-wire system = SA+SB+SC 3 wire system = 3-Phase real power
1060	True Power Factor, Phase A	1	Integer	RO	N	xx	0.001	1,000 -100 to 100 (-32,768 if N/A) ①	Derived using the complete harmonic content of real and apparent power. 4-wire system only
1061	True Power Factor, Phase B	1	Integer	RO	N	xx	0.001	1,000 -100 to 100 (-32,768 if N/A) ①	Derived using the complete harmonic content of real and apparent power. 4-wire system only
1062	True Power Factor, Phase C	1	Integer	RO	N	xx	0.001	1,000 -100 to 100 (-32,768 if N/A) ①	Derived using the complete harmonic content of real and apparent power. 4-wire system only
1063	True Power Factor, Total	1	Integer	RO	N	xx	0.001	1,000 -100 to 100 ①	Derived using the complete harmonic content of real and apparent power
1064	Alternate True Power Factor, Phase A	1	Integer	RO	N	xx	0.001	0 – 2,000 (-32,768 if N/A)	Derived using the complete harmonic content of real and apparent power (4-wire system only). Reported value is mapped from 0-2000, with 1000 representing unity, values below 1000 representing lagging, and values above 1000 representing leading.
1065	Alternate True Power Factor, Phase B	1	Integer	RO	N	xx	0.001	0 – 2,000 (-32,768 if N/A)	Derived using the complete harmonic content of real and apparent power (4-wire system only). Reported value is mapped from 0-2000, with 1000 representing unity, values below 1000 representing lagging, and values above 1000 representing leading.
1066	Alternate True Power Factor, Phase C	1	Integer	RO	N	xx	0.001	0 – 2,000 (-32,768 if N/A)	Derived using the complete harmonic content of real and apparent power (4-wire system only). Reported value is mapped from 0-2000, with 1000 representing unity, values below 1000 representing lagging, and values above 1000 representing leading.
1067	Alternate True Power Factor, Total	1	Integer	RO	N	xx	0.001	0 – 2,000	Derived using the complete harmonic content of real and apparent power. Reported value is mapped from 0-2000, with 1000 representing unity, values below 1000 representing lagging, and values above 1000 representing leading.

1-Second Real-Time Readings

1100	Current, Phase A	1	Integer	RO	N	A	Amperes/Scale	0 – 32,767	RMS
1101	Current, Phase B	1	Integer	RO	N	A	Amperes/Scale	0 – 32,767	RMS
1102	Current, Phase C	1	Integer	RO	N	A	Amperes/Scale	0 – 32,767	RMS
1103	Current, Neutral	1	Integer	RO	N	B	Amperes/Scale	0 – 32,767 (-32,768 if N/A)	RMS 4-wire system only
1104	Current, Ground	1	Integer	RO	N	C	Amperes/Scale	0 – 32,767 (-32,768 if N/A)	RMS 4-wire system only
1105	Current, 3-Phase Average	1	Integer	RO	N	A	Amperes/Scale	0 – 32,767	Calculated mean of Phases A, B & C
1106	Current, Apparent RMS	1	Integer	RO	N	A	Amperes/Scale	0 – 32,767	Peak instantaneous current of Phase A, B or C divided by $\sqrt{2}$

RO = Read only.
R/CW = Read configure writeable if in a setup session.
NV = Nonvolatile.
① See "How Power Factor is Stored in the Register" on page 122.
② See "How Date and Time Are Stored in Registers" on page 123.

Table A-3: Abbreviated Register List

Reg	Name	Size	Type	Access	NV	Scale	Units	Range	Notes
1107	Current, Unbalance, Phase A	1	Integer	RO	N	xx	0.10%	0 – 1,000	
1108	Current, Unbalance, Phase B	1	Integer	RO	N	xx	0.10%	0 – 1,000	
1109	Current, Unbalance, Phase C	1	Integer	RO	N	xx	0.10%	0 – 1,000	
1110	Current, Unbalance, Max	1	Integer	RO	N	xx	0.10%	0 – 1,000	Percent Unbalance, Worst
1120	Voltage, A-B	1	Integer	RO	N	D	Volts/Scale	0 – 32,767	Fundamental RMS Voltage measured between A & B
1121	Voltage, B-C	1	Integer	RO	N	D	Volts/Scale	0 – 32,767	Fundamental RMS Voltage measured between B & C
1122	Voltage, C-A	1	Integer	RO	N	D	Volts/Scale	0 – 32,767	Fundamental RMS Voltage measured between C & A
1123	Voltage, L-L Average	1	Integer	RO	N	D	Volts/Scale	0 – 32,767	Fundamental RMS 3 Phase Average L-L Voltage
1124	Voltage, A-N	1	Integer	RO	N	D	Volts/Scale	0 – 32,767 (-32,768 if N/A)	Fundamental RMS Voltage measured between A & N 4-wire system only
1125	Voltage, B-N	1	Integer	RO	N	D	Volts/Scale	0 – 32,767 (-32,768 if N/A)	Fundamental RMS Voltage measured between B & N 4-wire system only
1126	Voltage, C-N	1	Integer	RO	N	D	Volts/Scale	0 – 32,767 (-32,768 if N/A)	Fundamental RMS Voltage measured between C & N 4-wire system only
1128	Voltage, L-N Average	1	Integer	RO	N	D	Volts/Scale	0 – 32,767	Fundamental RMS 3-Phase Average L-N Voltage
1129	Voltage, Unbalance, A-B	1	Integer	RO	N	xx	0.10%	0 – 1,000	Percent Voltage Unbalance, Phase A-B
1130	Voltage, Unbalance, B-C	1	Integer	RO	N	xx	0.10%	0 – 1,000	Percent Voltage Unbalance, Phase B-C
1131	Voltage, Unbalance, C-A	1	Integer	RO	N	xx	0.10%	0 – 1,000	Percent Voltage Unbalance, Phase C-A
1132	Voltage, Unbalance, Max L-L	1	Integer	RO	N	xx	0.10%	0 – 1,000	Percent Voltage Unbalance, Worst L-L
1133	Voltage, Unbalance, A-N	1	Integer	RO	N	xx	0.10%	0 – 1,000 (-32,768 if N/A)	Percent Voltage Unbalance, Phase A-N 4-wire system only
1134	Voltage, Unbalance, B-N	1	Integer	RO	N	xx	0.10%	0 – 1,000 (-32,768 if N/A)	Percent Voltage Unbalance, Phase B-N 4-wire system only
1135	Voltage, Unbalance, C-N	1	Integer	RO	N	xx	0.10%	0 – 1,000 (-32,768 if N/A)	Percent Voltage Unbalance, Phase C-N 4-wire system only
1136	Voltage, Unbalance, Max L-N	1	Integer	RO	N	xx	0.10%	0 – 1,000 (-32,768 if N/A)	Percent Voltage Unbalance, Worst L-N 4-wire system only

RO = Read only.
R/CW = Read configure writeable if in a setup session.
NV = Nonvolatile.
① See "How Power Factor is Stored in the Register" on page 122.
② See "How Date and Time Are Stored in Registers" on page 123.

Table A-3: Abbreviated Register List

Reg	Name	Size	Type	Access	NV	Scale	Units	Range	Notes
1140	Real Power, Phase A	1	Integer	RO	N	F	kW/Scale	-32,767 – 32,767 (-32,768 if N/A)	Real Power (PA) 4-wire system only
1141	Real Power, Phase B	1	Integer	RO	N	F	kW/Scale	-32,767 – 32,767 (-32,768 if N/A)	Real Power (PB) 4-wire system only
1142	Real Power, Phase C	1	Integer	RO	N	F	kW/Scale	-32,767 – 32,767 (-32,768 if N/A)	Real Power (PC) 4-wire system only
1143	Real Power, Total	1	Integer	RO	N	F	kW/Scale	-32,767 – 32,767	4-wire system = PA+PB+PC 3-wire system = 3-Phase real power
1144	Reactive Power, Phase A	1	Integer	RO	N	F	kVar/Scale	-32,767 – 32,767 (-32,768 if N/A)	Reactive Power (QA) 4-wire system only
1145	Reactive Power, Phase B	1	Integer	RO	N	F	kVar/Scale	-32,767 – 32,767 (-32,768 if N/A)	Reactive Power (QB) 4-wire system only
1146	Reactive Power, Phase C	1	Integer	RO	N	F	kVar/Scale	-32,767 – 32,767 (-32,768 if N/A)	Reactive Power (QC) 4-wire system only
1147	Reactive Power, Total	1	Integer	RO	N	F	kVar/Scale	-32,767 – 32,767	4-wire system = QA+QB+QC 3 wire system = 3-Phase reactive power
1148	Apparent Power, Phase A	1	Integer	RO	N	F	kVA/Scale	-32,767 – 32,767 (-32,768 if N/A)	Apparent Power (SA) 4-wire system only
1149	Apparent Power, Phase B	1	Integer	RO	N	F	kVA/Scale	-32,767 – 32,767 (-32,768 if N/A)	Apparent Power (SB) 4-wire system only
1150	Apparent Power, Phase C	1	Integer	RO	N	F	kVA/Scale	-32,767 – 32,767 (-32,768 if N/A)	Apparent Power (SC) 4-wire system only
1151	Apparent Power, Total	1	Integer	RO	N	F	kVA/Scale	-32,767 – 32,767	4-wire system = SA+SB+SC 3-wire system = 3-Phase apparent power
1160	True Power Factor, Phase A	1	Integer	RO	N	xx	0.001	1,000 -100 to 100 (-32,768 if N/A) ①	Derived using the complete harmonic content of real and apparent power. 4-wire system only
1161	True Power Factor, Phase B	1	Integer	RO	N	xx	0.001	1,000 -100 to 100 (-32,768 if N/A) ①	Derived using the complete harmonic content of real and apparent power. 4-wire system only
1162	True Power Factor, Phase C	1	Integer	RO	N	xx	0.001	1,000 -100 to 100 (-32,768 if N/A) ①	Derived using the complete harmonic content of real and apparent power. 4-wire system only
1163	True Power Factor, Total	1	Integer	RO	N	xx	0.001	1,000 -100 to 100 ①	Derived using the complete harmonic content of real and apparent power
1164	Alternate True Power Factor, Phase A	1	Integer	RO	N	xx	0.001	0 – 2,000 (-32,768 if N/A)	Derived using the complete harmonic content of real and apparent power (4-wire system only). Reported value is mapped from 0-2000, with 1000 representing unity, values below 1000 representing lagging, and values above 1000 representing leading.
1165	Alternate True Power Factor, Phase B	1	Integer	RO	N	xx	0.001	0 – 2,000 (-32,768 if N/A)	Derived using the complete harmonic content of real and apparent power (4-wire system only). Reported value is mapped from 0-2000, with 1000 representing unity, values below 1000 representing lagging, and values above 1000 representing leading.
1166	Alternate True Power Factor, Phase C	1	Integer	RO	N	xx	0.001	0 – 2,000 (-32,768 if N/A)	Derived using the complete harmonic content of real and apparent power (4-wire system only). Reported value is mapped from 0-2000, with 1000 representing unity, values below 1000 representing lagging, and values above 1000 representing leading.

RO = Read only.
R/CW = Read configure writeable if in a setup session.
NV = Nonvolatile.
① See "How Power Factor is Stored in the Register" on page 122.
② See "How Date and Time Are Stored in Registers" on page 123.

Table A-3: Abbreviated Register List

Reg	Name	Size	Type	Access	NV	Scale	Units	Range	Notes
1167	Alternate True Power Factor, Total	1	Integer	RO	N	xx	0.001	0 – 2,000	Derived using the complete harmonic content of real and apparent power. Reported value is mapped from 0-2000, with 1000 representing unity, values below 1000 representing lagging, and values above 1000 representing leading.
1168	Displacement Power Factor, Phase A	1	Integer	RO	N	xx	0.001	1,000 -100 to 100 (-32,768 if N/A) ①	Derived using only fundamental frequency of the real and apparent power. 4-wire system only
1169	Displacement Power Factor, Phase B	1	Integer	RO	N	xx	0.001	1,000 -100 to 100 (-32,768 if N/A) ①	Derived using only fundamental frequency of the real and apparent power. 4-wire system only
1170	Displacement Power Factor, Phase C	1	Integer	RO	N	xx	0.001	1,000 -100 to 100 (-32,768 if N/A) ①	Derived using only fundamental frequency of the real and apparent power. 4-wire system only
1171	Displacement Power Factor, Total	1	Integer	RO	N	xx	0.001	1,000 -100 to 100 ①	Derived using only fundamental frequency of the real and apparent power
1172	Alternate Displacement Power Factor, Phase A	1	Integer	RO	N	xx	0.001	0 – 2,000 (-32,768 if N/A)	Derived using only fundamental frequency of the real and apparent power (4-wire system only). Reported value is mapped from 0-2000, with 1000 representing unity, values below 1000 representing lagging, and values above 1000 representing leading.
1173	Alternate Displacement Power Factor, Phase B	1	Integer	RO	N	xx	0.001	0 – 2,000 (-32,768 if N/A)	Derived using only fundamental frequency of the real and apparent power (4-wire system only). Reported value is mapped from 0-2000, with 1000 representing unity, values below 1000 representing lagging, and values above 1000 representing leading.
1174	Alternate Displacement Power Factor, Phase C	1	Integer	RO	N	xx	0.001	0 – 2,000 (-32,768 if N/A)	Derived using only fundamental frequency of the real and apparent power (4-wire system only). Reported value is mapped from 0-2000, with 1000 representing unity, values below 1000 representing lagging, and values above 1000 representing leading.
1175	Alternate Displacement Power Factor, Total	1	Integer	RO	N	xx	0.001	0 – 2,000	Derived using only fundamental frequency of the real and apparent power. Reported value is mapped from 0-2000, with 1000 representing unity, values below 1000 representing lagging, and values above 1000 representing leading.
1180	Frequency	1	Integer	RO	N	xx	0.01Hz 0.10Hz	(50/60Hz) 4,500 – 6,700 (400Hz) 3,500 – 4,500 (-32,768 if N/A)	Frequency of circuits being monitored. If the frequency is out of range, the register will be -32,768.

Power Quality

1200	THD/thd Current, Phase A	1	Integer	RO	N	xx	0.10%	0 – 32,767	Total Harmonic Distortion, Phase A Current Expressed as % of fundamental
1201	THD/thd Current, Phase B	1	Integer	RO	N	xx	0.10%	0 – 32,767	Total Harmonic Distortion, Phase B Current Expressed as % of fundamental

RO = Read only.

R/CW = Read configure writeable if in a setup session.

NV = Nonvolatile.

① See "How Power Factor is Stored in the Register" on page 122.

② See "How Date and Time Are Stored in Registers" on page 123.

Table A-3: Abbreviated Register List

Reg	Name	Size	Type	Access	NV	Scale	Units	Range	Notes
1202	THD/thd Current, Phase C	1	Integer	RO	N	xx	0.10%	0 – 32,767	Total Harmonic Distortion, Phase C Current Expressed as % of fundamental
1203	THD/thd Current, Phase N	1	Integer	RO	N	xx	0.10%	0 – 32,767 (-32,768 if N/A)	Total Harmonic Distortion, Phase N Current Expressed as % of fundamental 4-wire system only
1204	THD/thd Current, Ground	1	Integer	RO	N	xx	0.10%	0 – 32,767 (-32,768 if N/A)	Total Harmonic Distortion, Ground Current Expressed as % of fundamental
1207	THD/thd Voltage, Phase A-N	1	Integer	RO	N	xx	0.10%	0 – 32,767 (-32,768 if N/A)	Total Harmonic Distortion Expressed as % of fundamental 4-wire system only
1208	THD/thd Voltage, Phase B-N	1	Integer	RO	N	xx	0.10%	0 – 32,767 (-32,768 if N/A)	Total Harmonic Distortion Expressed as % of fundamental 4-wire system only
1209	THD/thd Voltage, Phase C-N	1	Integer	RO	N	xx	0.10%	0 – 32,767 (-32,768 if N/A)	Total Harmonic Distortion Expressed as % of fundamental 4-wire system only
1211	THD/thd Voltage, Phase A-B	1	Integer	RO	N	xx	0.10%	0 – 32,767	Total Harmonic Distortion Expressed as % of fundamental
1212	THD/thd Voltage, Phase B-C	1	Integer	RO	N	xx	0.10%	0 – 32,767	Total Harmonic Distortion Expressed as % of fundamental
1213	THD/thd Voltage, Phase C-A	1	Integer	RO	N	xx	0.10%	0 – 32,767	Total Harmonic Distortion Expressed as % of fundamental
1218	K-Factor, Current, Phase A	1	Integer	RO	N	xx	0.10	0 – 10,000	Updated with spectral components.
1219	K-Factor, Current, Phase B	1	Integer	RO	N	xx	0.10	0 – 10,000	Updated with spectral components.
1220	K-Factor, Current, Phase C	1	Integer	RO	N	xx	0.10	0 – 10,000	Updated with spectral components.
1221	Crest Factor, Current, Phase A	1	Integer	RO	N	xx	0.01	0 – 10,000	Transformer Crest Factor
1222	Crest Factor, Current, Phase B	1	Integer	RO	N	xx	0.01	0 – 10,000	Transformer Crest Factor
1223	Crest Factor, Current, Phase C	1	Integer	RO	N	xx	0.01	0 – 10,000	Transformer Crest Factor
1224	Crest Factor, Current, Neutral	1	Integer	RO	N	xx	0.01	0 – 10,000 (-32,768 if N/A)	Transformer Crest Factor 4-wire system only
1225	Crest Factor, Voltage, A-N/A-B	1	Integer	RO	N	xx	0.01	0 – 10,000	Transformer Crest Factor Voltage A-N (4-wire system) Voltage A-B (3-wire system)
1226	Crest Factor, Voltage, B-N/B-C	1	Integer	RO	N	xx	0.01	0 – 10,000	Transformer Crest Factor Voltage B-N (4-wire system) Voltage B-C (3-wire system)
1227	Crest Factor, Voltage, C-N/C-A	1	Integer	RO	N	xx	0.01	0 – 10,000	Transformer Crest Factor Voltage C-N (4-wire system) Voltage C-A (3-wire system)
1230	Current Fundamental RMS Magnitude, Phase A	1	Integer	RO	N	A	Amperes/Scale	0 – 32,767	
1231	Current Fundamental Coincident Angle, Phase A	1	Integer	RO	N	xx	0.1°	0 – 3,599	Referenced to A-N/A-B Voltage Angle

RO = Read only.
R/CW = Read configure writeable if in a setup session.
NV = Nonvolatile.
① See "How Power Factor is Stored in the Register" on page 122.
② See "How Date and Time Are Stored in Registers" on page 123.

Table A-3: Abbreviated Register List

Reg	Name	Size	Type	Access	NV	Scale	Units	Range	Notes
1232	Current Fundamental RMS Magnitude, Phase B	1	Integer	RO	N	A	Amperes/Scale	0 – 32,767	
1233	Current Fundamental Coincident Angle, Phase B	1	Integer	RO	N	xx	0.1°	0 – 3,599	Referenced to A-N/A-B Voltage Angle
1234	Current Fundamental RMS Magnitude, Phase C	1	Integer	RO	N	A	Amperes/Scale	0 – 32,767	
1235	Current Fundamental Coincident Angle, Phase C	1	Integer	RO	N	xx	0.1°	0 – 3,599	Referenced to A-N/A-B Voltage Angle
1236	Current Fundamental RMS Magnitude, Neutral	1	Integer	RO	N	B	Amperes/Scale	0 – 32,767 (-32,768 if N/A)	4-wire system only
1237	Current Fundamental Coincident Angle, Neutral	1	Integer	RO	N	xx	0.1°	0 – 3,599 (-32,768 if N/A)	Referenced to A-N 4-wire system only
1238	Current Fundamental RMS Magnitude, Ground	1	Integer	RO	N	C	Amperes/Scale	0 – 32,767 (-32,768 if N/A)	
1239	Current Fundamental Coincident Angle, Ground	1	Integer	RO	N	xx	0.1°	0 – 3,599 (-32,768 if N/A)	Referenced to A-N
1244	Voltage Fundamental RMS Magnitude, A-N/A-B	1	Integer	RO	N	D	Volts/Scale	0 – 32,767	Voltage A-N (4-wire system) Voltage A-B (3-wire system)
1245	Voltage Fundamental Coincident Angle, A-N/A-B	1	Integer	RO	N	xx	0.1°	0 – 3,599	Referenced to A-N (4-wire) or A-B (3-wire)
1246	Voltage Fundamental RMS Magnitude, B-N/B-C	1	Integer	RO	N	D	Volts/Scale	0 – 32,767	Voltage B-N (4-wire system) Voltage B-C (3-wire system)
1247	Voltage Fundamental Coincident Angle, B-N/B-C	1	Integer	RO	N	xx	0.1°	0 – 3,599	Referenced to A-N (4-wire) or A-B (3-wire)
1248	Voltage Fundamental RMS Magnitude, C-N/C-A	1	Integer	RO	N	D	Volts/Scale	0 – 32,767	Voltage C-N (4-wire system) Voltage C-A (3-wire system)
1249	Voltage Fundamental Coincident Angle, C-N/C-A	1	Integer	RO	N	xx	0.1°	0 – 3,599	Referenced to A-N (4-wire) or A-B (3-wire)
1255	Fundamental Real Power, Phase A	1	Integer	RO	N	F	kW/Scale	-32,767 – 32,767 (-32,768 if N/A)	4-wire system only

RO = Read only.
R/CW = Read configure writeable if in a setup session.
NV = Nonvolatile.
① See "How Power Factor is Stored in the Register" on page 122.
② See "How Date and Time Are Stored in Registers" on page 123.

Table A-3: Abbreviated Register List

Reg	Name	Size	Type	Access	NV	Scale	Units	Range	Notes
1256	Fundamental Real Power, Phase B	1	Integer	RO	N	F	kW/Scale	-32,767 – 32,767 (-32,768 if N/A)	4-wire system only
1257	Fundamental Real Power, Phase C	1	Integer	RO	N	F	kW/Scale	-32,767 – 32,767 (-32,768 if N/A)	4-wire system only
1258	Fundamental Real Power, Total	1	Integer	RO	N	F	kW/Scale	-32,767 – 32,767	
1259	Fundamental Reactive Power, Phase A	1	Integer	RO	N	F	kVAr/Scale	-32,767 – 32,767 (-32,768 if N/A)	4-wire system only
1260	Fundamental Reactive Power, Phase B	1	Integer	RO	N	F	kVAr/Scale	-32,767 – 32,767 (-32,768 if N/A)	4-wire system only
1261	Fundamental Reactive Power, Phase C	1	Integer	RO	N	F	kVAr/Scale	-32,767 – 32,767 (-32,768 if N/A)	4-wire system only
1262	Fundamental Reactive Power, Total	1	Integer	RO	N	F	kVAr/Scale	-32,767 – 32,767	
1264	Distortion Power, Phase A	1	Integer	RO	N	F	kW/Scale	-32,767 – 32,767 (-32,768 if N/A)	4-wire system only
1265	Distortion Power, Phase B	1	Integer	RO	N	F	kW/Scale	-32,767 – 32,767 (-32,768 if N/A)	4-wire system only
1266	Distortion Power, Phase C	1	Integer	RO	N	F	kW/Scale	-32,767 – 32,767 (-32,768 if N/A)	4-wire system only
1267	Distortion Power, Total	1	Integer	RO	N	F	kW/Scale	-32,767 – 32,767	
1268	Distortion Power Factor, Phase A	1	Integer	RO	N	xx	0.10%	0 – 1,000 (-32,768 if N/A)	4-wire system only
1269	Distortion Power Factor, Phase B	1	Integer	RO	N	xx	0.10%	0 – 1,000 (-32,768 if N/A)	4-wire system only
1270	Distortion Power Factor, Phase C	1	Integer	RO	N	xx	0.10%	0 – 1,000 (-32,768 if N/A)	4-wire system only
1271	Distortion Power Factor, Total	1	Integer	RO	N	xx	0.10%	0 – 1,000	
1274	Harmonic Current, Phase A	1	Integer	RO	N	A	Amperes/Scale	0 – 32,767	
1275	Harmonic Current, Phase B	1	Integer	RO	N	A	Amperes/Scale	0 – 32,767	
1276	Harmonic Current, Phase C	1	Integer	RO	N	A	Amperes/Scale	0 – 32,767	
1277	Harmonic Current, Neutral	1	Integer	RO	N	B	Amperes/Scale	0 – 32,767 (-32,768 if N/A)	4-wire system only
1278	Harmonic Voltage, A-N/A-B	1	Integer	RO	N	D	Volts/Scale	0 – 32,767	Voltage A-N (4-wire system) Voltage A-B (3-wire system)
1279	Harmonic Voltage, B-N/B-C	1	Integer	RO	N	D	Volts/Scale	0 – 32,767	Voltage B-N (4-wire system) Voltage B-C (3-wire system)
1280	Harmonic Voltage, C-N/C-A	1	Integer	RO	N	D	Volts/Scale	0 – 32,767	Voltage C-N (4-wire system) Voltage C-A (3-wire system)
1281	Total Demand Distortion	1	Integer	RO	N	xx	0.1%	0 – 1,000	Calculated based on Peak Current Demand Over Last Year entered by user in register 3233

RO = Read only.
R/CW = Read configure writeable if in a setup session.
NV = Nonvolatile.
① See "How Power Factor is Stored in the Register" on page 122.
② See "How Date and Time Are Stored in Registers" on page 123.

Table A-3: Abbreviated Register List

Reg	Name	Size	Type	Access	NV	Scale	Units	Range	Notes
1282	Harmonic Power Flow	1	Bitmap	RO	N	xx	xxxxxxx	0x0000 – 0x0F0F	Describes harmonic power flow per phase and total 0 = into load, 1 = out of load Bit 00 = kW Phase A Bit 01 = kW Phase B Bit 02 = kW Phase C Bit 03 = kW Total Bit 04 = reserved Bit 05 = reserved Bit 06 = reserved Bit 07 = reserved Bit 08 = kVAr Phase A Bit 09 = kVAr Phase B Bit 10 = kVAr Phase C Bit 11 = kVAr Total Bit 12 = reserved Bit 13 = reserved Bit 14 = reserved Bit 15 = reserved
1284	Current, Positive Sequence, Magnitude	1	Integer	RO	N	A	Amperes/Scale	0 – 32,767	
1285	Current, Positive Sequence, Angle	1	Integer	RO	N	xx	0.1	0 – 3,599	
1286	Current, Negative Sequence, Magnitude	1	Integer	RO	N	A	Amperes/Scale	0 – 32,767	
1287	Current, Negative Sequence, Angle	1	Integer	RO	N	xx	0.1	0 – 3,599	
1288	Current, Zero Sequence, Magnitude	1	Integer	RO	N	A	Amperes/Scale	0 – 32,767	
1289	Current, Zero Sequence, Angle	1	Integer	RO	N	xx	0.1	0 – 3,599	
1290	Voltage, Positive Sequence, Magnitude	1	Integer	RO	N	D	Volts/Scale	0 – 32,767	
1291	Voltage, Positive Sequence, Angle	1	Integer	RO	N	xx	0.1	0 – 3,599	
1292	Voltage, Negative Sequence, Magnitude	1	Integer	RO	N	D	Volts/Scale	0 – 32,767	
1293	Voltage, Negative Sequence, Angle	1	Integer	RO	N	xx	0.1	0 – 3,599	
1294	Voltage, Zero Sequence, Magnitude	1	Integer	RO	N	D	Volts/Scale	0 – 32,767	
1295	Voltage, Zero Sequence, Angle	1	Integer	RO	N	xx	0.1	0 – 3,599	
1296	Current, Sequence, Unbalance	1	Integer	RO	N	xx	0.10%	0 – 32,767	

RO = Read only.
R/CW = Read configure writeable if in a setup session.
NV = Nonvolatile.
① See "How Power Factor is Stored in the Register" on page 122.
② See "How Date and Time Are Stored in Registers" on page 123.

Table A-3: Abbreviated Register List

Reg	Name	Size	Type	Access	NV	Scale	Units	Range	Notes
1297	Voltage, Sequence, Unbalance	1	Integer	RO	N	xx	0.10%	0 – 32,767	
1298	Current, Sequence Unbalance Factor	1	Integer	RO	N	xx	0.10%	0 – 1,000	Negative Sequence / Positive Sequence
1299	Voltage, Sequence Unbalance Factor	1	Integer	RO	N	xx	0.10%	0 – 1,000	Negative Sequence / Positive Sequence

Real-Time Minimum Metered Values

1300	Minimum Current, Phase A	1	Integer	RO	Y	A	Amperes/Scale	0 – 32,767	RMS
1301	Minimum Current, Phase B	1	Integer	RO	Y	A	Amperes/Scale	0 – 32,767	RMS
1302	Minimum Current, Phase C	1	Integer	RO	Y	A	Amperes/Scale	0 – 32,767	RMS
1303	Minimum Current, Neutral	1	Integer	RO	Y	B	Amperes/Scale	0 – 32,767 (-32,768 if N/A)	RMS 4-wire system only
1304	Minimum Current, Ground	1	Integer	RO	Y	C	Amperes/Scale	0 – 32,767 (-32,768 if N/A)	Minimum calculated RMS ground current
1305	Minimum Current, 3-Phase Average	1	Integer	RO	Y	A	Amperes/Scale	0 – 32,767	Minimum calculated mean of Phases A, B & C
1306	Minimum Current, Apparent RMS	1	Integer	RO	Y	A	Amperes/Scale	0 – 32,767	Minimum peak instantaneous current of Phase A, B or C divided by $\sqrt{2}$
1307	Minimum Current Unbalance, Phase A	1	Integer	RO	Y	xx	0.10%	0 – 1,000	
1308	Minimum Current Unbalance, Phase B	1	Integer	RO	Y	xx	0.10%	0 – 1,000	
1309	Minimum Current Unbalance, Phase C	1	Integer	RO	Y	xx	0.10%	0 – 1,000	
1310	Minimum Current Unbalance, Max	1	Integer	RO	Y	xx	0.10%	0 – 1,000	
1320	Minimum Voltage, A-B	1	Integer	RO	Y	D	Volts/Scale	0 – 32767	Minimum fundamental RMS Voltage between A & B
1321	Minimum Voltage, B-C	1	Integer	RO	Y	D	Volts/Scale	0 – 32767	Minimum fundamental RMS Voltage between B & C
1322	Minimum Voltage, C-A	1	Integer	RO	Y	D	Volts/Scale	0 – 32767	Minimum fundamental RMS Voltage between C & A
1323	Minimum Voltage, L-L Average	1	Integer	RO	Y	D	Volts/Scale	0 – 32767	Minimum fundamental RMS Average L-L Voltage
1324	Minimum Voltage, A-N	1	Integer	RO	Y	D	Volts/Scale	0 – 32767 (-32,768 if N/A)	Minimum fundamental RMS Voltage between A & N 4-wire system only

RO = Read only.
R/CW = Read configure writeable if in a setup session.
NV = Nonvolatile.
① See "How Power Factor is Stored in the Register" on page 122.
② See "How Date and Time Are Stored in Registers" on page 123.

Table A-3:Abbreviated Register List

Reg	Name	Size	Type	Access	NV	Scale	Units	Range	Notes
1325	Minimum Voltage, B-N	1	Integer	RO	Y	D	Volts/Scale	0 – 32767 (-32,768 if N/A)	Minimum fundamental RMS Voltage between B & N 4-wire system only
1326	Minimum Voltage, C-N	1	Integer	RO	Y	D	Volts/Scale	0 – 32767 (-32,768 if N/A)	Minimum fundamental RMS Voltage between C & N 4-wire system only
1328	Minimum Voltage, L-N Average	1	Integer	RO	Y	D	Volts/Scale	0 – 32767 (-32,768 if N/A)	Minimum fundamental RMS L-N Voltage 4-wire system only
1329	Minimum Voltage Unbalance, A-B	1	Integer	RO	Y	xx	0.10%	0 – 1,000	
1330	Minimum Voltage Unbalance, B-C	1	Integer	RO	Y	xx	0.10%	0 – 1,000	
1331	Minimum Voltage Unbalance, C-A	1	Integer	RO	Y	xx	0.10%	0 – 1,000	
1332	Minimum Voltage Unbalance, Max L-L	1	Integer	RO	Y	xx	0.10%	0 – 1,000	Minimum percent Voltage Unbalance, Worst L-L Depends on absolute value
1333	Minimum Voltage Unbalance, A-N	1	Integer	RO	Y	xx	0.10%	0 – 1,000 (-32,768 if N/A)	
1334	Minimum Voltage Unbalance, B-N	1	Integer	RO	Y	xx	0.10%	0 – 1,000 (-32,768 if N/A)	
1335	Minimum Voltage Unbalance, C-N	1	Integer	RO	Y	xx	0.10%	0 – 1,000 (-32,768 if N/A)	
1336	Minimum Voltage Unbalance, Max L-N	1	Integer	RO	Y	xx	0.10%	0 – 1,000 (-32,768 if N/A)	Minimum percent Voltage Unbalance, Worst L-N Depends on absolute value 4-wire system only
1340	Minimum Real Power, Phase A	1	Integer	RO	Y	F	kW/Scale	-32,767 – 32,767 (-32,768 if N/A)	Minimum Real Power (PA) 4-wire system only
1341	Minimum Real Power, Phase B	1	Integer	RO	Y	F	kW/Scale	-32,767 – 32,767 (-32,768 if N/A)	Minimum Real Power (PB) 4-wire system only
1342	Minimum Real Power, Phase C	1	Integer	RO	Y	F	kW/Scale	-32,767 – 32,767 (-32,768 if N/A)	Minimum Real Power (PC) 4-wire system only
1343	Minimum Real Power, Total	1	Integer	RO	Y	F	kW/Scale	-32,767 – 32,767	4-wire system = PA+PB+PC 3 wire system = 3-Phase real power
1344	Minimum Reactive Power, Phase A	1	Integer	RO	Y	F	kVAr/Scale	-32,767 – 32,767 (-32,768 if N/A)	Minimum Reactive Power (QA) 4-wire system only
1345	Minimum Reactive Power, Phase B	1	Integer	RO	Y	F	kVAr/Scale	-32,767 – 32,767 (-32,768 if N/A)	Minimum Reactive Power (QB) 4-wire system only
1346	Minimum Reactive Power, Phase C	1	Integer	RO	Y	F	kVAr/Scale	-32,767 – 32,767 (-32,768 if N/A)	Minimum Reactive Power (QC) 4-wire system only
1347	Minimum Reactive Power, Total	1	Integer	RO	Y	F	kVAr/Scale	-32,767 – 32,767	4-wire system = QA+QB+QC 3-wire system = 3-Phase reactive power
1348	Minimum Apparent Power, Phase A	1	Integer	RO	Y	F	kVA/Scale	-32,767 – 32,767 (-32,768 if N/A)	Minimum Apparent Power (SA) 4-wire system only
1349	Minimum Apparent Power, Phase B	1	Integer	RO	Y	F	kVA /Scale	-32,767 – 32,767 (-32,768 if N/A)	Minimum Apparent Power (SB) 4-wire system only
1350	Minimum Apparent Power, Phase C	1	Integer	RO	Y	F	kVA /Scale	-32,767 – 32,767 (-32,768 if N/A)	Minimum Apparent Power (SC) 4-wire system only

RO = Read only.

R/CW = Read configure writeable if in a setup session.

NV = Nonvolatile.

① See "How Power Factor is Stored in the Register" on page 122.

② See "How Date and Time Are Stored in Registers" on page 123.

Table A–3:Abbreviated Register List

Reg	Name	Size	Type	Access	NV	Scale	Units	Range	Notes
1351	Minimum Apparent Power, Total	1	Integer	RO	Y	F	kVA /Scale	-32,767 – 32,767	4-wire system = SA+SB+SC 3-wire system = 3-Phase apparent power
1360	Minimum True Power Factor, Phase A	1	Integer	RO	Y	xx	0.001	1,000 -100 to 100 (-32,768 if N/A) ①	Derived using the complete harmonic content of real and apparent power. 4-wire system only
1361	Minimum True Power Factor, Phase B	1	Integer	RO	Y	xx	0.001	1,000 -100 to 100 (-32,768 if N/A) ①	Derived using the complete harmonic content of real and apparent power. 4-wire system only
1362	Minimum True Power Factor, Phase C	1	Integer	RO	Y	xx	0.001	1,000 -100 to 100 (-32,768 if N/A) ①	Derived using the complete harmonic content of real and apparent power. 4-wire system only
1363	Minimum True Power Factor, Total	1	Integer	RO	Y	xx	0.001	1,000 -100 to 100 ①	Derived using the complete harmonic content of real and apparent power
1364	Minimum Alternate True Power Factor, Phase A	1	Integer	RO	Y	xx	0.001	0 – 2,000 (-32,768 if N/A)	Derived using the complete harmonic content of real and apparent power (4-wire system only). Reported value is mapped from 0-2000, with 1000 representing unity, values below 1000 representing lagging, and values above 1000 representing leading.
1365	Minimum Alternate True Power Factor, Phase B	1	Integer	RO	Y	xx	0.001	0 – 2,000 (-32,768 if N/A)	Derived using the complete harmonic content of real and apparent power (4-wire system only). Reported value is mapped from 0-2000, with 1000 representing unity, values below 1000 representing lagging, and values above 1000 representing leading.
1366	Minimum Alternate True Power Factor, Phase C	1	Integer	RO	Y	xx	0.001	0 – 2,000 (-32,768 if N/A)	Derived using the complete harmonic content of real and apparent power (4-wire system only). Reported value is mapped from 0-2000, with 1000 representing unity, values below 1000 representing lagging, and values above 1000 representing leading.
1367	Minimum Alternate True Power Factor, Total	1	Integer	RO	Y	xx	0.001	0 – 2,000	Derived using the complete harmonic content of real and apparent power. Reported value is mapped from 0-2000, with 1000 representing unity, values below 1000 representing lagging, and values above 1000 representing leading.
1368	Minimum Displacement Power Factor, Phase A	1	Integer	RO	Y	xx	0.001	1,000 -100 to 100 (-32,768 if N/A) ①	Derived using only fundamental frequency of the real and apparent power. 4-wire system only
1369	Minimum Displacement Power Factor, Phase B	1	Integer	RO	Y	xx	0.001	1,000 -100 to 100 (-32,768 if N/A) ①	Derived using only fundamental frequency of the real and apparent power. 4-wire system only
1370	Minimum Displacement Power Factor, Phase C	1	Integer	RO	Y	xx	0.001	1,000 -100 to 100 (-32,768 if N/A) ①	Derived using only fundamental frequency of the real and apparent power. 4-wire system only
1371	Minimum Displacement Power Factor, Total	1	Integer	RO	Y	xx	0.001	1,000 -100 to 100 ①	Derived using only fundamental frequency of the real and apparent power

RO = Read only.
R/CW = Read configure writeable if in a setup session.
NV = Nonvolatile.
①See "How Power Factor is Stored in the Register" on page 122.
②See "How Date and Time Are Stored in Registers" on page 123.

Table A-3: Abbreviated Register List

Reg	Name	Size	Type	Access	NV	Scale	Units	Range	Notes
1372	Minimum Alternate Displacement Power Factor, Phase A	1	Integer	RO	Y	xx	0.001	0 – 2,000 (-32,768 if N/A)	Derived using only fundamental frequency of the real and apparent power (4-wire system only). Reported value is mapped from 0-2000, with 1000 representing unity, values below 1000 representing lagging, and values above 1000 representing leading.
1373	Minimum Alternate Displacement Power Factor, Phase B	1	Integer	RO	Y	xx	0.001	0 – 2,000 (-32,768 if N/A)	Derived using only fundamental frequency of the real and apparent power (4-wire system only). Reported value is mapped from 0-2000, with 1000 representing unity, values below 1000 representing lagging, and values above 1000 representing leading.
1374	Minimum Alternate Displacement Power Factor, Phase C	1	Integer	RO	Y	xx	0.001	0 – 2,000 (-32,768 if N/A)	Derived using only fundamental frequency of the real and apparent power (4-wire system only). Reported value is mapped from 0-2000, with 1000 representing unity, values below 1000 representing lagging, and values above 1000 representing leading.
1375	Minimum Alternate Displacement Power Factor, Total	1	Integer	RO	Y	xx	0.001	0 – 2,000	Derived using only fundamental frequency of the real and apparent power. Reported value is mapped from 0-2000, with 1000 representing unity, values below 1000 representing lagging, and values above 1000 representing leading.
1380	Minimum Frequency	1	Integer	RO	Y	xx	0.01Hz 0.10Hz	(50/60Hz) 4,500 – 6,700 (400Hz) 3,500 – 4,500 (-32,768 if N/A)	Minimum frequency of circuits being monitored. If the frequency is out of range, the register will be -32,768.
1381	Minimum Temperature	1	Integer	RO	Y	xx	0.1°C	-1,000 – 1,000	Minimum internal unit temperature
1400	Minimum THD/thd Current, Phase A	1	Integer	RO	Y	xx	0.10%	0 – 32,767	Minimum Total Harmonic Distortion, Phase A Current Expressed as % of fundamental
1401	Minimum THD/thd Current, Phase B	1	Integer	RO	Y	xx	0.10%	0 – 32,767	Minimum Total Harmonic Distortion, Phase B Current Expressed as % of fundamental
1402	Minimum THD/thd Current, Phase C	1	Integer	RO	Y	xx	0.10%	0 – 32,767	Minimum Total Harmonic Distortion, Phase C Current Expressed as % of fundamental
1403	Minimum THD/thd Current, Phase N	1	Integer	RO	Y	xx	0.10%	0 – 32,767 (-32,768 if N/A)	Minimum Total Harmonic Distortion, Phase N Current Expressed as % of fundamental 4-wire system only
1404	Minimum THD/thd Current, Ground	1	Integer	RO	Y	xx	0.10%	0 – 32,767 (-32,768 if N/A)	Minimum Total Harmonic Distortion, Ground Current Expressed as % of fundamental
1407	Minimum THD/thd Voltage, Phase A-N	1	Integer	RO	Y	xx	0.10%	0 – 32,767 (-32,768 if N/A)	Minimum Total Harmonic Distortion Expressed as % of fundamental 4-wire system only
1408	Minimum THD/thd Voltage, Phase B-N	1	Integer	RO	Y	xx	0.10%	0 – 32,767 (-32,768 if N/A)	Minimum Total Harmonic Distortion Expressed as % of fundamental 4-wire system only
1409	Minimum THD/thd Voltage, Phase C-N	1	Integer	RO	Y	xx	0.10%	0 – 32,767 (-32,768 if N/A)	Minimum Total Harmonic Distortion Expressed as % of fundamental 4-wire system only

RO = Read only.
R/CW = Read configure writeable if in a setup session.
NV = Nonvolatile.
① See "How Power Factor is Stored in the Register" on page 122.
② See "How Date and Time Are Stored in Registers" on page 123.

Table A-3: Abbreviated Register List

Reg	Name	Size	Type	Access	NV	Scale	Units	Range	Notes
1411	Minimum THD/ thd Voltage, Phase A-B	1	Integer	RO	Y	xx	0.10%	0 – 32,767	Minimum Total Harmonic Distortion Expressed as % of fundamental
1412	Minimum THD/ thd Voltage, Phase B-C	1	Integer	RO	Y	xx	0.10%	0 – 32,767	Minimum Total Harmonic Distortion Expressed as % of fundamental
1413	Minimum THD/ thd Voltage, Phase C-A	1	Integer	RO	Y	xx	0.10%	0 – 32,767	Minimum Total Harmonic Distortion Expressed as % of fundamental
1418	Minimum Current K-Factor, Phase A	1	Integer	RO	Y	xx	0.10	0 – 10,000	
1419	Minimum Current K-Factor, Phase B	1	Integer	RO	Y	xx	0.10	0 – 10,000	
1420	Minimum Current K-Factor, Phase C	1	Integer	RO	Y	xx	0.10	0 – 10,000	
1421	Minimum Crest Factor, Current, Phase A	1	Integer	RO	Y	xx	0.01	0 – 10,000	Minimum Transformer Crest Factor
1422	Minimum Crest Factor, Current, Phase B	1	Integer	RO	Y	xx	0.01	0 – 10,000	Minimum Transformer Crest Factor
1423	Minimum Crest Factor, Current, Phase C	1	Integer	RO	Y	xx	0.01	0 – 10,000	Minimum Transformer Crest Factor
1424	Minimum Crest Factor, Current, Neutral	1	Integer	RO	Y	xx	0.01	0 – 10,000 (-32,768 if N/A)	Minimum Transformer Crest Factor 4-wire system only
1425	Minimum Crest Factor, Voltage A-N/A-B	1	Integer	RO	Y	xx	0.01	0 – 10,000	Minimum Transformer Crest Factor Voltage A-N (4-wire system) Voltage A-B (3-wire system)
1426	Minimum Crest Factor, Voltage B-N/B-C	1	Integer	RO	Y	xx	0.01	0 – 10,000	Minimum Transformer Crest Factor Voltage B-N (4-wire system) Voltage B-C (3-wire system)
1427	Minimum Crest Factor, Voltage C-N/C-A	1	Integer	RO	Y	xx	0.01	0 – 10,000	Minimum Transformer Crest Factor Voltage C-N (4-wire system) Voltage C-A (3-wire system)
1430	Minimum Current Fundamental RMS Magnitude, Phase A	1	Integer	RO	Y	A	Amperes/Scale	0 – 32,767	
1431	Minimum Current Fundamental Coincident Angle, Phase A	1	Integer	RO	Y	xx	0.1°	0 – 3,599	Angle at the time of magnitude minimum Referenced to A-N/A-B Voltage Angle
1432	Minimum Current Fundamental RMS Magnitude, Phase B	1	Integer	RO	Y	A	Amperes/Scale	0 – 32,767	
1433	Minimum Current Fundamental Coincident Angle, Phase B	1	Integer	RO	Y	xx	0.1°	0 – 3,599	Angle at the time of magnitude minimum Referenced to A-N/A-B Voltage Angle
1434	Minimum Current Fundamental RMS Magnitude, Phase C	1	Integer	RO	Y	A	Amperes/Scale	0 – 32,767	

RO = Read only.
R/CW = Read configure writeable if in a setup session.
NV = Nonvolatile.
① See "How Power Factor is Stored in the Register" on page 122.
② See "How Date and Time Are Stored in Registers" on page 123.

Table A-3:Abbreviated Register List

Reg	Name	Size	Type	Access	NV	Scale	Units	Range	Notes
1435	Minimum Current Fundamental Coincident Angle, Phase C	1	Integer	RO	Y	xx	0.1°	0 – 3,599	Angle at the time of magnitude minimum Referenced to A-N/A-B Voltage Angle
1436	Minimum Current Fundamental RMS Magnitude, Neutral	1	Integer	RO	Y	B	Amperes/Scale	0 – 32,767 (-32,768 if N/A)	4-wire system only
1437	Minimum Current Fundamental Coincident Angle, Neutral	1	Integer	RO	Y	xx	0.1°	0 – 3,599 (-32,768 if N/A)	Angle at the time of magnitude minimum Referenced to A-N 4-wire system only
1438	Minimum Current Fundamental RMS Magnitude, Ground	1	Integer	RO	Y	C	Amperes/Scale	0 – 32,767 (-32,768 if N/A)	
1439	Minimum Current Fundamental Coincident Angle, Ground	1	Integer	RO	Y	xx	0.1°	0 – 3,599 (-32,768 if N/A)	Angle at the time of magnitude minimum Referenced to A-N
1444	Minimum Voltage Fundamental RMS Magnitude, A-N/A-B	1	Integer	RO	Y	D	Volts/Scale	0 – 32,767	Voltage A-N (4-wire system) Voltage A-B (3-wire system)
1445	Minimum Voltage Fundamental Coincident Angle, A-N/A-B	1	Integer	RO	Y	xx	0.1°	0 – 3,599	Angle at the time of magnitude minimum Referenced to itself)
1446	Minimum Voltage Fundamental RMS Magnitude, B-N/B-C	1	Integer	RO	Y	D	Volts/Scale	0 – 32,767	Voltage B-N (4-wire system) Voltage B-C (3-wire system)
1447	Minimum Voltage Fundamental Coincident Angle, B-N/B-C	1	Integer	RO	Y	xx	0.1°	0 – 3,599	Angle at the time of magnitude minimum Referenced to A-N (4-wire) or A-B (3-wire)
1448	Minimum Voltage Fundamental RMS Magnitude, C-N/C-A	1	Integer	RO	Y	D	Volts/Scale	0 – 32,767	Voltage C-N (4-wire system) Voltage C-A (3-wire system)
1449	Minimum Voltage Fundamental Coincident Angle, C-N/C-A	1	Integer	RO	Y	xx	0.1°	0 – 3,599	Angle at the time of magnitude minimum Referenced to A-N (4-wire) or A-B (3-wire)
1455	Minimum Fundamental Real Power, Phase A	1	Integer	RO	Y	F	kW/Scale	-32,767 – 32,767 (-32,768 if N/A)	4-wire system only
1456	Minimum Fundamental Real Power, Phase B	1	Integer	RO	Y	F	kW/Scale	-32,767 – 32,767 (-32,768 if N/A)	4-wire system only
1457	Minimum Fundamental Real Power, Phase C	1	Integer	RO	Y	F	kW/Scale	-32,767 – 32,767 (-32,768 if N/A)	4-wire system only
1458	Minimum Fundamental Real Power, Total	1	Integer	RO	Y	F	kW/Scale	-32,767 – 32,767	

RO = Read only.
R/CW = Read configure writeable if in a setup session.
NV = Nonvolatile.
① See "How Power Factor is Stored in the Register" on page 122.
② See "How Date and Time Are Stored in Registers" on page 123.

Table A-3: Abbreviated Register List

Reg	Name	Size	Type	Access	NV	Scale	Units	Range	Notes
1459	Minimum Fundamental Reactive Power, Phase A	1	Integer	RO	Y	F	kVAr/Scale	-32,767 – 32,767 (-32,768 if N/A)	4-wire system only
1460	Minimum Fundamental Reactive Power, Phase B	1	Integer	RO	Y	F	kVAr/Scale	-32,767 – 32,767 (-32,768 if N/A)	4-wire system only
1461	Minimum Fundamental Reactive Power, Phase C	1	Integer	RO	Y	F	kVAr/Scale	-32,767 – 32,767 (-32,768 if N/A)	4-wire system only
1462	Minimum Fundamental Reactive Power, Total	1	Integer	RO	Y	F	kVAr/Scale	-32,767 – 32,767	
1464	Minimum Distortion Power, Phase A	1	Integer	RO	Y	F	kW/Scale	-32,767 – 32,767 (-32,768 if N/A)	4-wire system only
1465	Minimum Distortion Power, Phase B	1	Integer	RO	Y	F	kW/Scale	-32,767 – 32,767 (-32,768 if N/A)	4-wire system only
1466	Minimum Distortion Power, Phase C	1	Integer	RO	Y	F	kW/Scale	-32,767 – 32,767 (-32,768 if N/A)	4-wire system only
1467	Minimum Distortion Power, Total	1	Integer	RO	Y	F	kW/Scale	-32,767 – 32,767	
1468	Minimum Distortion Power Factor, Phase A	1	Integer	RO	Y	xx	0.10%	0 – 1,000 (-32,768 if N/A)	4-wire system only
1469	Minimum Distortion Power Factor, Phase B	1	Integer	RO	Y	xx	0.10%	0 – 1,000 (-32,768 if N/A)	4-wire system only
1470	Minimum Distortion Power Factor, Phase C	1	Integer	RO	Y	xx	0.10%	0 – 1,000 (-32,768 if N/A)	4-wire system only
1471	Minimum Distortion Power Factor, Total	1	Integer	RO	Y	xx	0.10%	0 – 1,000	
1474	Minimum Harmonic Current, Phase A	1	Integer	RO	Y	A	Amperes/Scale	0 – 32,767	
1475	Minimum Harmonic Current, Phase B	1	Integer	RO	Y	A	Amperes/Scale	0 – 32,767	
1476	Minimum Harmonic Current, Phase C	1	Integer	RO	Y	A	Amperes/Scale	0 – 32,767	
1477	Minimum Harmonic Current, Neutral	1	Integer	RO	Y	B	Amperes/Scale	0 – 32,767 (-32,768 if N/A)	4-wire system only
1478	Minimum Harmonic Voltage, A-N/A-B	1	Integer	RO	Y	D	Volts/Scale	0 – 32,767	Voltage A-N (4-wire system) Voltage A-B (3-wire system)
1479	Minimum Harmonic Voltage, B-N/B-C	1	Integer	RO	Y	D	Volts/Scale	0 – 32,767	Voltage B-N (4-wire system) Voltage B-C (3-wire system)

RO = Read only.
R/CW = Read configure writeable if in a setup session.
NV = Nonvolatile.
① See "How Power Factor is Stored in the Register" on page 122.
② See "How Date and Time Are Stored in Registers" on page 123.

Table A-3:Abbreviated Register List

Reg	Name	Size	Type	Access	NV	Scale	Units	Range	Notes
1480	Minimum Harmonic Voltage, C-N/C-A	1	Integer	RO	Y	D	Volts/Scale	0 – 32,767	Voltage C-N (4-wire system) Voltage C-A (3-wire system)
1481	Minimum Total Demand Distortion	1	Integer	RO	Y	xx	0.01%	0 – 10,000	
1484	Minimum Current, Positive Sequence, Magnitude	1	Integer	RO	Y	A	Amperes/Scale	0 – 32,767	
1485	Minimum Current, Positive Sequence, Angle	1	Integer	RO	Y	xx	0.1	0 – 3,599	
1486	Minimum Current, Negative Sequence, Magnitude	1	Integer	RO	Y	A	Amperes/Scale	0 – 32,767	
1487	Minimum Current, Negative Sequence, Angle	1	Integer	RO	Y	xx	0.1	0 – 3,599	
1488	Minimum Current, Zero Sequence, Magnitude	1	Integer	RO	Y	A	Amperes/Scale	0 – 32,767	
1489	Minimum Current, Zero Sequence, Angle	1	Integer	RO	Y	xx	0.1	0 – 3,599	
1490	Minimum Voltage, Positive Sequence, Magnitude	1	Integer	RO	Y	D	Volts/Scale	0 – 32,767	
1491	Minimum Voltage, Positive Sequence, Angle	1	Integer	RO	Y	xx	0.1	0 – 3,599	
1492	Minimum Voltage, Negative Sequence, Magnitude	1	Integer	RO	Y	D	Volts/Scale	0 – 32,767	
1493	Minimum Voltage, Negative Sequence, Angle	1	Integer	RO	Y	xx	0.1	0 – 3,599	
1494	Minimum Voltage, Zero Sequence, Magnitude	1	Integer	RO	Y	D	Volts/Scale	0 – 32,767	
1495	Minimum Voltage, Zero Sequence, Angle	1	Integer	RO	Y	xx	0.1	0 – 3,599	
1496	Minimum Current, Sequence, Unbalance	1	Integer	RO	Y	xx	0.10%	-1,000 – 1,000	
1497	Minimum Voltage, Sequence, Unbalance	1	Integer	RO	Y	xx	0.10%	-1,000 – 1,000	

RO = Read only.

R/CW = Read configure writeable if in a setup session.

NV = Nonvolatile.

① See "How Power Factor is Stored in the Register" on page 122.

② See "How Date and Time Are Stored in Registers" on page 123.

Table A-3: Abbreviated Register List

Reg	Name	Size	Type	Access	NV	Scale	Units	Range	Notes
1498	Minimum Current, Sequence Unbalance Factor	1	Integer	RO	N	xx	0.10%	0 – 1,000	Negative Sequence / Positive Sequence
1499	Minimum Voltage, Sequence Unbalance Factor	1	Integer	RO	N	xx	0.10%	0 – 1,000	Negative Sequence / Positive Sequence

Real-Time Maximum Metered Values

1500	Maximum Current, Phase A	1	Integer	RO	Y	A	Amperes/Scale	0 – 32,767	RMS
1501	Maximum Current, Phase B	1	Integer	RO	Y	A	Amperes/Scale	0 – 32,767	RMS
1502	Maximum Current, Phase C	1	Integer	RO	Y	A	Amperes/Scale	0 – 32,767	RMS
1503	Maximum Current, Neutral	1	Integer	RO	Y	B	Amperes/Scale	0 – 32,767 (-32,768 if N/A)	RMS 4-wire system only
1504	Maximum Current, Ground	1	Integer	RO	Y	C	Amperes/Scale	0 – 32,767 (-32,768 if N/A)	Maximum calculated RMS ground current
1505	Maximum Current, 3 Phase Average	1	Integer	RO	Y	A	Amperes/Scale	0 – 32,767	Maximum calculated mean of Phases A, B & C
1506	Maximum Current, Apparent RMS	1	Integer	RO	Y	A	Amperes/Scale	0 – 32,767	Maximum peak instantaneous current of Phase A, B or C divided by $\sqrt{2}$
1507	Maximum Current Unbalance, Phase A	1	Integer	RO	Y	xx	0.10%	0 – 1,000	
1508	Maximum Current Unbalance, Phase B	1	Integer	RO	Y	xx	0.10%	0 – 1,000	
1509	Maximum Current Unbalance, Phase C	1	Integer	RO	Y	xx	0.10%	0 – 1,000	
1510	Maximum Current Unbalance, Max	1	Integer	RO	Y	xx	0.10%	0 – 1,000	
1520	Maximum Voltage, A-B	1	Integer	RO	Y	D	Volts/Scale	0 – 32767	Maximum fundamental RMS Voltage between A & B
1521	Maximum Voltage, B-C	1	Integer	RO	Y	D	Volts/Scale	0 – 32767	Maximum fundamental RMS Voltage between B & C
1522	Maximum Voltage, C-A	1	Integer	RO	Y	D	Volts/Scale	0 – 32767	Maximum fundamental RMS Voltage between C & A
1523	Maximum Voltage, L-L Average	1	Integer	RO	Y	D	Volts/Scale	0 – 32767	Maximum fundamental RMS Average L-L Voltage
1524	Maximum Voltage, A-N	1	Integer	RO	Y	D	Volts/Scale	0 – 32767 (-32,768 if N/A)	Maximum fundamental RMS Voltage between A & N 4-wire system only
1525	Maximum Voltage, B-N	1	Integer	RO	Y	D	Volts/Scale	0 – 32767 (-32,768 if N/A)	Maximum fundamental RMS Voltage between B & N 4-wire system only

RO = Read only.
R/CW = Read configure writeable if in a setup session.
NV = Nonvolatile.
① See "How Power Factor is Stored in the Register" on page 122.
② See "How Date and Time Are Stored in Registers" on page 123.

Table A-3:Abbreviated Register List

Reg	Name	Size	Type	Access	NV	Scale	Units	Range	Notes
1526	Maximum Voltage, C-N	1	Integer	RO	Y	D	Volts/Scale	0 – 32767 (-32,768 if N/A)	Maximum fundamental RMS Voltage between C & N 4-wire system only
1528	Maximum Voltage, L-N Average	1	Integer	RO	Y	D	Volts/Scale	0 – 32767 (-32,768 if N/A)	Maximum fundamental RMS L-N Voltage 4-wire system only
1529	Maximum Voltage Unbalance, A-B	1	Integer	RO	Y	xx	0.10%	0 – 1,000	
1530	Maximum Voltage Unbalance, B-C	1	Integer	RO	Y	xx	0.10%	0 – 1,000	
1531	Maximum Voltage Unbalance, C-A	1	Integer	RO	Y	xx	0.10%	0 – 1,000	
1532	Maximum Voltage Unbalance, Max L-L	1	Integer	RO	Y	xx	0.10%	0 – 1,000	Maximum percent Voltage Unbalance, Worst L-L Depends on absolute value
1533	Maximum Voltage Unbalance, A-N	1	Integer	RO	Y	xx	0.10%	0 – 1,000 (-32,768 if N/A)	
1534	Maximum Voltage Unbalance, B-N	1	Integer	RO	Y	xx	0.10%	0 – 1,000 (-32,768 if N/A)	
1535	Maximum Voltage Unbalance, C-N	1	Integer	RO	Y	xx	0.10%	0 – 1,000 (-32,768 if N/A)	
1536	Maximum Voltage Unbalance, Max L-N	1	Integer	RO	Y	xx	0.10%	0 – 1,000 (-32,768 if N/A)	Maximum percent Voltage Unbalance, Worst L-N Depends on absolute value (4-wire system only)
1540	Maximum Real Power, Phase A	1	Integer	RO	Y	F	kW/Scale	-32,767 – 32,767 (-32,768 if N/A)	Maximum Real Power (PA) 4-wire system only
1541	Maximum Real Power, Phase B	1	Integer	RO	Y	F	kW/Scale	-32,767 – 32,767 (-32,768 if N/A)	Maximum Real Power (PB) 4-wire system only
1542	Maximum Real Power, Phase C	1	Integer	RO	Y	F	kW/Scale	-32,767 – 32,767 (-32,768 if N/A)	Maximum Real Power (PC) 4-wire system only
1543	Maximum Real Power, Total	1	Integer	RO	Y	F	kW/Scale	-32,767 – 32,767	4-wire system = PA+PB+PC 3 wire system = 3-Phase real power
1544	Maximum Reactive Power, Phase A	1	Integer	RO	Y	F	kVAr/Scale	-32,767 – 32,767 (-32,768 if N/A)	Maximum Reactive Power (QA) 4-wire system only
1545	Maximum Reactive Power, Phase B	1	Integer	RO	Y	F	kVAr/Scale	-32,767 – 32,767 (-32,768 if N/A)	Maximum Reactive Power (QB) 4-wire system only
1550	Maximum Apparent Power, Phase C	1	Integer	RO	Y	F	kVA /Scale	-32,767 – 32,767 (-32,768 if N/A)	Maximum Apparent Power (SC) 4-wire system only

RO = Read only.
R/CW = Read configure writeable if in a setup session.
NV = Nonvolatile.
① See "How Power Factor is Stored in the Register" on page 122.
② See "How Date and Time Are Stored in Registers" on page 123.

Table A-3: Abbreviated Register List

Reg	Name	Size	Type	Access	NV	Scale	Units	Range	Notes
1551	Maximum Apparent Power, Total	1	Integer	RO	Y	F	kVA /Scale	-32,767 – 32,767	4-wire system = SA+SB+SC 3-wire system = 3-Phase apparent power
1560	Maximum True Power Factor, Phase A	1	Integer	RO	Y	xx	0.001	1,000 -100 to 100 (-32,768 if N/A) ①	Derived using the complete harmonic content of real and apparent power (4-wire system only)
1561	Maximum True Power Factor, Phase B	1	Integer	RO	Y	xx	0.001	1,000 -100 to 100 (-32,768 if N/A) ①	Derived using the complete harmonic content of real and apparent power (4-wire system only)
1562	Maximum True Power Factor, Phase C	1	Integer	RO	Y	xx	0.001	1,000 -100 to 100 (-32,768 if N/A) ①	Derived using the complete harmonic content of real and apparent power (4-wire system only)
1563	Maximum True Power Factor, Total	1	Integer	RO	Y	xx	0.001	1,000 -100 to 100 ①	Derived using the complete harmonic content of real and apparent power
1564	Maximum Alternate True Power Factor, Phase A	1	Integer	RO	Y	xx	0.001	0 – 2,000 (-32,768 if N/A)	Derived using the complete harmonic content of real and apparent power (4-wire system only). Reported value is mapped from 0-2000, with 1000 representing unity, values below 1000 representing lagging, and values above 1000 representing leading.
1565	Maximum Alternate True Power Factor, Phase B	1	Integer	RO	Y	xx	0.001	0 – 2,000 (-32,768 if N/A)	Derived using the complete harmonic content of real and apparent power (4-wire system only). Reported value is mapped from 0-2000, with 1000 representing unity, values below 1000 representing lagging, and values above 1000 representing leading.
1566	Maximum Alternate True Power Factor, Phase C	1	Integer	RO	Y	xx	0.001	0 – 2,000 (-32,768 if N/A)	Derived using the complete harmonic content of real and apparent power (4-wire system only). Reported value is mapped from 0-2000, with 1000 representing unity, values below 1000 representing lagging, and values above 1000 representing leading.
1567	Maximum Alternate True Power Factor, Total	1	Integer	RO	Y		0.001	0 – 2,000	Derived using the complete harmonic content of real and apparent power. Reported value is mapped from 0-2000, with 1000 representing unity, values below 1000 representing lagging, and values above 1000 representing leading.
1568	Maximum Displacement Power Factor, Phase A	1	Integer	RO	Y	xx	0.001	1,000 -100 to 100 (-32,768 if N/A) ①	Derived using only fundamental frequency of the real and apparent power. 4-wire system only
1569	Maximum Displacement Power Factor, Phase B	1	Integer	RO	Y	xx	0.001	1,000 -100 to 100 (-32,768 if N/A) ①	Derived using only fundamental frequency of the real and apparent power. 4-wire system only
1570	Maximum Displacement Power Factor, Phase C	1	Integer	RO	Y	xx	0.001	1,000 -100 to 100 (-32,768 if N/A) ①	Derived using only fundamental frequency of the real and apparent power. 4-wire system only
1571	Maximum Displacement Power Factor, Total	1	Integer	RO	Y	xx	0.001	1,000 -100 to 100 ①	Derived using only fundamental frequency of the real and apparent power

RO = Read only.
R/CW = Read configure writeable if in a setup session.
NV = Nonvolatile.
① See "How Power Factor is Stored in the Register" on page 122.
② See "How Date and Time Are Stored in Registers" on page 123.

Table A-3: Abbreviated Register List

Reg	Name	Size	Type	Access	NV	Scale	Units	Range	Notes
1572	Maximum Alternate Displacement Power Factor, Phase A	1	Integer	RO	Y	xx	0.001	0 – 2,000 (-32,768 if N/A)	Derived using only fundamental frequency of the real and apparent power (4-wire system only). Reported value is mapped from 0-2000, with 1000 representing unity, values below 1000 representing lagging, and values above 1000 representing leading.
1573	Maximum Alternate Displacement Power Factor, Phase B	1	Integer	RO	Y	xx	0.001	0 – 2,000 (-32,768 if N/A)	Derived using only fundamental frequency of the real and apparent power (4-wire system only). Reported value is mapped from 0-2000, with 1000 representing unity, values below 1000 representing lagging, and values above 1000 representing leading.
1574	Maximum Alternate Displacement Power Factor, Phase C	1	Integer	RO	Y	xx	0.001	0 – 2,000 (-32,768 if N/A)	Derived using only fundamental frequency of the real and apparent power (4-wire system only). Reported value is mapped from 0-2000, with 1000 representing unity, values below 1000 representing lagging, and values above 1000 representing leading.
1575	Maximum Alternate Displacement Power Factor, Total	1	Integer	RO	Y	xx	0.001	0 – 2,000	Derived using only fundamental frequency of the real and apparent power. Reported value is mapped from 0-2000, with 1000 representing unity, values below 1000 representing lagging, and values above 1000 representing leading.
1580	Maximum Frequency	1	Integer	RO	Y	xx	0.01Hz 0.10Hz	(50/60Hz) 4,500 – 6,700 (400Hz) 3,500 – 4,500 (-32,768 if N/A)	Frequency of circuits being monitored. If the frequency is out of range, the register will be -32,768.
1581	Maximum Temperature	1	Integer	RO	Y	xx	0.1°C	-1,000 – 1,000	Internal unit temperature
1590	Maximum Auxiliary Analog Input Value, User-Selected Input 1	1	Integer	RO	Y	xx	Refer to Analog Input Setup	-32,767 – 32,767 (-32,768 if N/A)	
1600	Maximum THD/thd Current, Phase A	1	Integer	RO	Y	xx	0.10%	0 – 32,767	Maximum Total Harmonic Distortion, Phase A Current Expressed as % of fundamental
1601	Maximum THD/thd Current, Phase B	1	Integer	RO	Y	xx	0.10%	0 – 32,767	Maximum Total Harmonic Distortion, Phase B Current Expressed as % of fundamental
1602	Maximum THD/thd Current, Phase C	1	Integer	RO	Y	xx	0.10%	0 – 32,767	Maximum Total Harmonic Distortion, Phase C Current Expressed as % of fundamental
1603	Maximum THD/thd Current, Phase N	1	Integer	RO	Y	xx	0.10%	0 – 32,767 (-32,768 if N/A)	Maximum Total Harmonic Distortion, Phase N Current Expressed as % of fundamental 4-wire system only
1604	Maximum THD/thd Current, Ground	1	Integer	RO	Y	xx	0.10%	0 – 32,767 (-32,768 if N/A)	Maximum Total Harmonic Distortion, Ground Current Expressed as % of fundamental

RO = Read only.
R/CW = Read configure writeable if in a setup session.
NV = Nonvolatile.
① See "How Power Factor is Stored in the Register" on page 122.
② See "How Date and Time Are Stored in Registers" on page 123.

Table A-3: Abbreviated Register List

Reg	Name	Size	Type	Access	NV	Scale	Units	Range	Notes
1605	Maximum THD/ thd Current, Alternate I2	1	Integer	RO	Y	xx	0.10%	0 – 32,767 (-32,768 if N/A)	Maximum Total Harmonic Distortion, Alternate I2 Current Expressed as % of fundamental
1606	Maximum THD/ thd Current, Alternate I4	1	Integer	RO	Y	xx	0.10%	0 – 32,767 (-32,768 if N/A)	Maximum Total Harmonic Distortion, Alternate I4 Current Expressed as % of fundamental
1607	Maximum THD/ thd Voltage, Phase A-N	1	Integer	RO	Y	xx	0.10%	0 – 32,767 (-32,768 if N/A)	Maximum Total Harmonic Distortion Expressed as % of fundamental 4-wire system only
1608	Maximum THD/ thd Voltage, Phase B-N	1	Integer	RO	Y	xx	0.10%	0 – 32,767 (-32,768 if N/A)	Maximum Total Harmonic Distortion Expressed as % of fundamental 4-wire system only
1609	Maximum THD/ thd Voltage, Phase C-N	1	Integer	RO	Y	xx	0.10%	0 – 32,767 (-32,768 if N/A)	Maximum Total Harmonic Distortion Expressed as % of fundamental 4-wire system only
1610	Maximum THD/ thd Voltage, Phase N-G	1	Integer	RO	Y	xx	0.10%	0 – 32,767 (-32,768 if N/A)	Maximum Total Harmonic Distortion Expressed as % of fundamental 4-wire system only
1611	Maximum THD/ thd Voltage, Phase A-B	1	Integer	RO	Y	xx	0.10%	0 – 32,767	Maximum Total Harmonic Distortion Expressed as % of fundamental
1612	Maximum THD/ thd Voltage, Phase B-C	1	Integer	RO	Y	xx	0.10%	0 – 32,767	Maximum Total Harmonic Distortion Expressed as % of fundamental
1613	Maximum THD/ thd Voltage, Phase C-A	1	Integer	RO	Y	xx	0.10%	0 – 32,767	Maximum Total Harmonic Distortion Expressed as % of fundamental
1618	Maximum Current K-Factor, Phase A	1	Integer	RO	Y	xx	0.10	0 – 10,000	
1619	Maximum Current K-Factor, Phase B	1	Integer	RO	Y	xx	0.10	0 – 10,000	
1620	Maximum Current K-Factor, Phase C	1	Integer	RO	Y	xx	0.10	0 – 10,000	
1621	Maximum Crest Factor, Current, Phase A	1	Integer	RO	Y	xx	0.01	0 – 10,000	Maximum Transformer Crest Factor
1622	Maximum Crest Factor, Current, Phase B	1	Integer	RO	Y	xx	0.01	0 – 10,000	Maximum Transformer Crest Factor
1623	Maximum Crest Factor, Current, Phase C	1	Integer	RO	Y	xx	0.01	0 – 10,000	Maximum Transformer Crest Factor
1624	Maximum Crest Factor, Current, Neutral	1	Integer	RO	Y	xx	0.01	0 – 10,000 (-32,768 if N/A)	Maximum Transformer Crest Factor 4-wire system only
1625	Maximum Crest Factor, Voltage A-N/A-B	1	Integer	RO	Y	xx	0.01	0 – 10,000	Maximum Transformer Crest Factor Voltage A-N (4-wire system) Voltage A-B (3-wire system)

RO = Read only.
R/CW = Read configure writeable if in a setup session.
NV = Nonvolatile.
① See "How Power Factor is Stored in the Register" on page 122.
② See "How Date and Time Are Stored in Registers" on page 123.

Table A-3:Abbreviated Register List

Reg	Name	Size	Type	Access	NV	Scale	Units	Range	Notes
1626	Maximum Crest Factor, Voltage B-N/B-C	1	Integer	RO	Y	xx	0.01	0 – 10,000	Maximum Transformer Crest Factor Voltage B-N (4-wire system) Voltage B-C (3-wire system)
1627	Maximum Crest Factor, Voltage C-N/C-A	1	Integer	RO	Y	xx	0.01	0 – 10,000	Maximum Transformer Crest Factor Voltage C-N (4-wire system) Voltage C-A (3-wire system)
1630	Maximum Current Fundamental RMS Magnitude, Phase A	1	Integer	RO	Y	A	Amperes/Scale	0 – 32,767	
1631	Maximum Current Fundamental Coincident Angle, Phase A	1	Integer	RO	Y	xx	0.1°	0 – 3,599	Angle at the time of magnitude Maximum Referenced to A-N/A-B Voltage Angle
1632	Maximum Current Fundamental RMS Magnitude, Phase B	1	Integer	RO	Y	A	Amperes/Scale	0 – 32,767	
1633	Maximum Current Fundamental Coincident Angle, Phase B	1	Integer	RO	Y	xx	0.1°	0 – 3,599	Angle at the time of magnitude Maximum Referenced to A-N/A-B Voltage Angle
1634	Maximum Current Fundamental RMS Magnitude, Phase C	1	Integer	RO	Y	A	Amperes/Scale	0 – 32,767	
1635	Maximum Current Fundamental Coincident Angle, Phase C	1	Integer	RO	Y	xx	0.1°	0 – 3,599	Angle at the time of magnitude Maximum Referenced to A-N/A-B Voltage Angle
1636	Maximum Current Fundamental RMS Magnitude, Neutral	1	Integer	RO	Y	B	Amperes/Scale	0 – 32,767 (-32,768 if N/A)	4-wire system only
1637	Maximum Current Fundamental Coincident Angle, Neutral	1	Integer	RO	Y	xx	0.1°	0 – 3,599 (-32,768 if N/A)	Angle at the time of magnitude Maximum Referenced to A-N 4-wire system only
1638	Maximum Current Fundamental RMS Magnitude, Ground	1	Integer	RO	Y	C	Amperes/Scale	0 – 32,767 (-32,768 if N/A)	
1639	Maximum Current Fundamental Coincident Angle, Ground	1	Integer	RO	Y	xx	0.1°	0 – 3,599 (-32,768 if N/A)	Angle at the time of magnitude Maximum Referenced to A-N
1644	Maximum Voltage Fundamental RMS Magnitude, A-N/A-B	1	Integer	RO	Y	D	Volts/Scale	0 – 32,767	Voltage A-N (4-wire system) Voltage A-B (3-wire system)

RO = Read only.
R/CW = Read configure writeable if in a setup session.
NV = Nonvolatile.
① See "How Power Factor is Stored in the Register" on page 122.
② See "How Date and Time Are Stored in Registers" on page 123.

Table A-3: Abbreviated Register List

Reg	Name	Size	Type	Access	NV	Scale	Units	Range	Notes
1645	Maximum Voltage Fundamental Coincident Angle, A-N/A-B	1	Integer	RO	Y	xx	0.1°	0 – 3,599	Angle at the time of magnitude Maximum Referenced to itself
1646	Maximum Voltage Fundamental RMS Magnitude, B-N/B-C	1	Integer	RO	Y	D	Volts/Scale	0 – 32,767	Voltage B-N (4-wire system) Voltage B-C (3-wire system)
1647	Maximum Voltage Fundamental Coincident Angle, B-N/B-C	1	Integer	RO	Y	xx	0.1°	0 – 3,599	Angle at the time of magnitude Maximum Referenced to A-N (4-wire) or A-B (3-wire)
1648	Maximum Voltage Fundamental RMS Magnitude, C-N/C-A	1	Integer	RO	Y	D	Volts/Scale	0 – 32,767	Voltage C-N (4-wire system) Voltage C-A (3-wire system)
1649	Maximum Voltage Fundamental Coincident Angle, C-N/C-A	1	Integer	RO	Y	xx	0.1°	0 – 3,599	Angle at the time of magnitude Maximum Referenced to A-N (4-wire) or A-B (3-wire)
1655	Maximum Fundamental Real Power, Phase A	1	Integer	RO	Y	F	kW/Scale	-32,767 – 32,767 (-32,768 if N/A)	4-wire system only
1656	Maximum Fundamental Real Power, Phase B	1	Integer	RO	Y	F	kW/Scale	-32,767 – 32,767 (-32,768 if N/A)	4-wire system only
1657	Maximum Fundamental Real Power, Phase C	1	Integer	RO	Y	F	kW/Scale	-32,767 – 32,767 (-32,768 if N/A)	4-wire system only
1658	Maximum Fundamental Real Power, Total	1	Integer	RO	Y	F	kW/Scale	-32,767 – 32,767	
1659	Maximum Fundamental Reactive Power, Phase A	1	Integer	RO	Y	F	kVAr/Scale	-32,767 – 32,767 (-32,768 if N/A)	4-wire system only
1660	Maximum Fundamental Reactive Power, Phase B	1	Integer	RO	Y	F	kVAr/Scale	-32,767 – 32,767 (-32,768 if N/A)	4-wire system only
1661	Maximum Fundamental Reactive Power, Phase C	1	Integer	RO	Y	F	kVAr/Scale	-32,767 – 32,767 (-32,768 if N/A)	4-wire system only
1662	Maximum Fundamental Reactive Power, Total	1	Integer	RO	Y	F	kVAr/Scale	-32,767 – 32,767	
1664	Maximum Distortion Power, Phase A	1	Integer	RO	Y	F	kW/Scale	-32,767 – 32,767 (-32,768 if N/A)	4-wire system only

RO = Read only.
R/CW = Read configure writeable if in a setup session.
NV = Nonvolatile.
① See "How Power Factor is Stored in the Register" on page 122.
② See "How Date and Time Are Stored in Registers" on page 123.

Table A-3:Abbreviated Register List

Reg	Name	Size	Type	Access	NV	Scale	Units	Range	Notes
1665	Maximum Distortion Power, Phase B	1	Integer	RO	Y	F	kW/Scale	-32,767 – 32,767 (-32,768 if N/A)	4-wire system only
1666	Maximum Distortion Power, Phase C	1	Integer	RO	Y	F	kW/Scale	-32,767 – 32,767 (-32,768 if N/A)	4-wire system only
1667	Maximum Distortion Power, Total	1	Integer	RO	Y	F	kW/Scale	-32,767 – 32,767	
1668	Maximum Distortion Factor, Phase A	1	Integer	RO	Y	F	0.10	0 – 1,000 (-32,768 if N/A)	4-wire system only
1669	Maximum Distortion Factor, Phase B	1	Integer	RO	Y	F	0.10	0 – 1,000 (-32,768 if N/A)	4-wire system only
1670	Maximum Distortion Factor, Phase C	1	Integer	RO	Y	F	0.10	0 – 1,000 (-32,768 if N/A)	4-wire system only
1671	Maximum Distortion Factor, Total	1	Integer	RO	Y	F	0.10	0 – 1,000	
1674	Maximum Harmonic Current, Phase A	1	Integer	RO	Y	A	Amperes/Scale	0 – 32,767	
1675	Maximum Harmonic Current, Phase B	1	Integer	RO	Y	A	Amperes/Scale	0 – 32,767	
1676	Maximum Harmonic Current, Phase C	1	Integer	RO	Y	A	Amperes/Scale	0 – 32,767	
1677	Maximum Harmonic Current, Neutral	1	Integer	RO	Y	B	Amperes/Scale	0 – 32,767 (-32,768 if N/A)	4-wire system only
1678	Maximum Harmonic Voltage A	1	Integer	RO	Y	D	Volts/Scale	0 – 32,767	Voltage A-N (4-wire system) Voltage A-B (3-wire system)
1679	Maximum Harmonic Voltage B	1	Integer	RO	Y	D	Volts/Scale	0 – 32,767	Voltage B-N (4-wire system) Voltage B-C (3-wire system)
1680	Maximum Harmonic Voltage C	1	Integer	RO	Y	D	Volts/Scale	0 – 32,767	Voltage C-N (4-wire system) Voltage C-A (3-wire system)
1681	Maximum Total Demand Distortion	1	Integer	RO	Y	xx	0.01%	0 – 10,000	
1684	Maximum Current, Positive Sequence, Magnitude	1	Integer	RO	Y	A	Amperes/Scale	0 – 32,767	
1685	Maximum Current, Positive Sequence, Angle	1	Integer	RO	Y	xx	0.1°	0 – 3,599	
1686	Maximum Current, Negative Sequence, Magnitude	1	Integer	RO	Y	A	Amperes/Scale	0 – 32,767	

RO = Read only.
R/CW = Read configure writeable if in a setup session.
NV = Nonvolatile.
① See "How Power Factor is Stored in the Register" on page 122.
② See "How Date and Time Are Stored in Registers" on page 123.

Table A-3: Abbreviated Register List

Reg	Name	Size	Type	Access	NV	Scale	Units	Range	Notes
1687	Maximum Current, Negative Sequence, Angle	1	Integer	RO	Y	xx	0.1°	0 – 3,599	
1688	Maximum Current, Zero Sequence, Magnitude	1	Integer	RO	Y	A	Amperes/Scale	0 – 32,767	
1689	Maximum Current, Zero Sequence, Angle	1	Integer	RO	Y	xx	0.1°	0 – 3,599	
1690	Maximum Voltage, Positive Sequence, Magnitude	1	Integer	RO	Y	D	Volts/Scale	0 – 32,767	
1691	Maximum Voltage, Positive Sequence, Angle	1	Integer	RO	Y	xx	0.1°	0 – 3,599	
1692	Maximum Voltage, Negative Sequence, Magnitude	1	Integer	RO	Y	D	Volts/Scale	0 – 32,767	
1693	Maximum Voltage, Negative Sequence, Angle	1	Integer	RO	Y	xx	0.1°	0 – 3,599	
1694	Maximum Voltage, Zero Sequence, Magnitude	1	Integer	RO	Y	D	Volts/Scale	0 – 32,767	
1695	Maximum Voltage, Zero Sequence, Angle	1	Integer	RO	Y	xx	0.1°	0 – 3,599	
1696	Maximum Current, Sequence, Unbalance	1	Integer	RO	Y	xx	0.10%	-1,000 – 1,000	
1697	Maximum Voltage, Sequence, Unbalance	1	Integer	RO	Y	xx	0.10%	-1,000 – 1,000	
1698	Maximum Current, Sequence Unbalance Factor	1	Integer	RO	N	xx	0.10%	0 – 1,000	Negative Sequence / Positive Sequence
1699	Maximum Voltage, Sequence Unbalance Factor	1	Integer	RO	N	xx	0.10%	0 – 1,000	Negative Sequence / Positive Sequence

Accumulated Energy

1700	Energy, Real In	4	Mod10	RO	Y	xx	WH	(1)	3-Phase total real energy into the load
1704	Energy, Reactive In	4	Mod10	RO	Y	xx	VARH	(1)	3-Phase total reactive energy into the load
1708	Energy, Real Out	4	Mod10	RO	Y	xx	WH	(1)	3-Phase total real energy out of the load

RO = Read only.
R/CW = Read configure writeable if in a setup session.
NV = Nonvolatile.
① See "How Power Factor is Stored in the Register" on page 122.
② See "How Date and Time Are Stored in Registers" on page 123.

Table A-3: Abbreviated Register List

Reg	Name	Size	Type	Access	NV	Scale	Units	Range	Notes
1712	Energy, Reactive Out	4	Mod10	RO	Y	xx	VArH	(1)	3-Phase total reactive energy out of the load
1716	Energy, Real Total (signed/ absolute)	4	Mod10	RO	Y	xx	WH	(2)	Total Real Energy In, Out or In + Out
1720	Energy, Reactive Total (signed/ absolute)	4	Mod10	RO	Y	xx	VArH	(2)	Total Reactive Energy In, Out or In + Out
1724	Energy, Apparent	4	Mod10	RO	Y	xx	VAH	(1)	3-Phase total apparent energy
1728	Energy, Conditional Real In	4	Mod10	RO	Y	xx	WH	(1)	3-Phase total accumulated conditional real energy into the load
1732	Energy, Conditional Reactive In	4	Mod10	RO	Y	xx	VArH	(1)	3-Phase total accumulated conditional reactive energy into the load
1736	Energy, Conditional Real Out	4	Mod10	RO	Y	xx	WH	(1)	3-Phase total accumulated conditional real energy out of the load
1740	Energy, Conditional Reactive Out	4	Mod10	RO	Y	xx	VArH	(1)	3-Phase total accumulated conditional reactive energy out of the load
1744	Energy, Conditional Apparent	4	Mod10	RO	Y	xx	VAH	(1)	3-Phase total accumulated conditional apparent energy
1748	Energy, Incremental Real In, Last Complete Interval	3	Mod10	RO	Y	xx	WH	(3)	3-Phase total accumulated incremental real energy into the load
1751	Energy, Incremental Reactive In, Last Complete Interval	3	Mod10	RO	Y	xx	VArH	(3)	3-Phase total accumulated incremental reactive energy into the load
1754	Energy, Incremental Real Out, Last Complete Interval	3	Mod10	RO	Y	xx	WH	(3)	3-Phase total accumulated incremental real energy out of the load
1757	Energy, Incremental Reactive Out, Last Complete Interval	3	Mod10	RO	Y	xx	VArH	(3)	3-Phase total accumulated incremental reactive energy out of the load
1760	Energy, Incremental Apparent, Last Complete Interval	3	Mod10	RO	Y	xx	VAH	(3)	3-Phase total accumulated incremental apparent energy
1763	DateTime Last Complete Incremental Energy Interval	4	DateTime	RO	Y	xx	See Template ②	See Template ②	
1767	Energy, Incremental Real In, Present Interval	3	Mod10	RO	Y	xx	WH	(3)	3-Phase total accumulated incremental real energy into the load

RO = Read only.

R/CW = Read configure writeable if in a setup session.

NV = Nonvolatile.

① See "How Power Factor is Stored in the Register" on page 122.

② See "How Date and Time Are Stored in Registers" on page 123.

Table A-3: Abbreviated Register List

Reg	Name	Size	Type	Access	NV	Scale	Units	Range	Notes
1770	Energy, Incremental Reactive In, Present Interval	3	Mod10	RO	Y	xx	VArH	(3)	3-Phase total accumulated incremental reactive energy into the load
1773	Energy, Incremental Real Out, Present Interval	3	Mod10	RO	Y	xx	WH	(3)	3-Phase total accumulated incremental real energy out of the load
1776	Energy, Incremental Reactive Out, Present Interval	3	Mod10	RO	Y	xx	VArH	(3)	3-Phase total accumulated incremental reactive energy out of the load
1779	Energy, Incremental Apparent, Present Interval	3	Mod10	RO	Y	xx	VAH	(3)	3-Phase total accumulated incremental apparent energy
1782	Energy, Reactive, Quadrant 1	3	Mod10	RO	Y	xx	VArH	(3)	3-Phase total accumulated incremental reactive energy – quadrant 1
1785	Energy, Reactive, Quadrant 2	3	Mod10	RO	Y	xx	VArH	(3)	3-Phase total accumulated incremental reactive energy – quadrant 2
1788	Energy, Reactive, Quadrant 3	3	Mod10	RO	Y	xx	VArH	(3)	3-Phase total accumulated incremental reactive energy – quadrant 3
1791	Energy, Reactive, Quadrant 4	3	Mod10	RO	Y	xx	VArH	(3)	3-Phase total accumulated incremental reactive energy – quadrant 4
1794	Conditional Energy Control Status	1	Integer	RO	Y	xx	xx	0 – 1	0 = Off (default) 1 = On

Note:

(1) 0 – 9,999,999,999,999,999

(2) -9,999,999,999,999,999 – 9,999,999,999,999,999

(3) 0 – 999,999,999,999

Demand

1800	Demand Calculation Mode Current	1	Integer	R/CW	Y	xx	xxxxxxx	0	0 = Thermal Demand (default)
1801	Demand Interval Current	1	Integer	R/CW	Y	xx	Minutes	1 – 60	Default = 15
1803	Demand Sensitivity Current	1	Integer	R/CW	Y	xx	1%	1 – 99	Adjusts the sensitivity of the thermal demand calculation. Default = 90
1805	Short Demand Interval Current	1	Integer	R/CW	Y	xx	Seconds	0 – 60	Sets the interval for a running average demand calculation of short duration. Default = 15
1806	Time Elapsed in Interval Current	1	Integer	RO	Y	xx	Seconds	0 – 3,600	
1808	Interval Count Current	1	Integer	RO	Y	xx	1.0	0 – 32,767	Rolls over at 32,767.
1810	Min/Max Reset DateTime Current	4	DateTime	RO	Y	xx	See Template	See Template ②	Date/Time of last reset of Current Demand Min/Max demands
1814	Min/Max Reset Count Current	1	Integer	RO	Y	xx	1.0	0 – 32,767	Count of Min/Max demand resets. Rolls over at 32,767.

RO = Read only.

R/CW = Read configure writeable if in a setup session.

NV = Nonvolatile.

① See "How Power Factor is Stored in the Register" on page 122.

② See "How Date and Time Are Stored in Registers" on page 123.

Table A-3: Abbreviated Register List

Reg	Name	Size	Type	Access	NV	Scale	Units	Range	Notes
1820	Demand Calculation Mode Voltage	1	Integer	R/CW	Y	xx	xxxxxxx	0 – 1024	0 = Thermal Demand (default) 1 = Timed Interval Sliding Block 2 = Timed Interval Block 4 = Timed Interval Rolling Block 8 = Input Synchronized Block 6 = Input Synchronized Rolling Block 32 = Command Synchronized Block 64 = Command Synchronized Rolling Block 128 = Clock Synchronized Block 256 = Clock Synchronized Rolling Block 512 = Slave to Power Demand Interval 1024 = Slave to Incremental Energy Interval
1821	Demand Interval Voltage	1	Integer	R/CW	Y	xx	Minutes	1 – 60	Default = 15
1822	Demand Subinterval Voltage	1	Integer	R/CW	Y	xx	Minutes	1 – 60	Default = 1
1823	Demand Sensitivity Voltage	1	Integer	R/CW	Y	xx	1%	1 – 99	Adjusts the sensitivity of the thermal demand calculation. Default = 90
1825	Short Demand Interval Voltage	1	Integer	R/CW	Y	xx	Seconds	0 – 60	Sets the interval for a running average demand calculation of short duration. Default = 15
1826	Time Elapsed in Interval Voltage	1	Integer	RO	Y	xx	Seconds	0 – 3,600	
1827	Time Elapsed in Subinterval Voltage	1	Integer	RO	Y	xx	Seconds	0 – 3,600	
1828	Interval Count Voltage	1	Integer	RO	Y	xx	1.0	0 – 32,767	Rolls over at 32,767.
1829	Subinterval Count Voltage	1	Integer	RO	Y	xx	1.0	0 – 60	Rolls over at interval.
1830	Min/Max Reset DateTime Voltage	4	DateTime	RO	Y	xx	See Template ②	See Template ②	
1834	Min/Max Reset Count Voltage	1	Integer	RO	Y	xx	1.0	0 – 32,767	Rolls over at 32,767.
1840	Demand Calculation Mode Power	1	Integer	R/CW	Y	xx	xxxxxxx	0 – 1024	0 = Thermal Demand (default) 1 = Timed Interval Sliding Block 2 = Timed Interval Block 4 = Timed Interval Rolling Block 8 = Input Synchronized Block 16 = Input Synchronized Rolling Block 32 = Command Synchronized Block 64 = Command Synchronized Rolling Block 128 = Clock Synchronized Block 256 = Clock Synchronized Rolling Block 1024 = Slave to Incremental Energy Interval
1841	Demand Interval Power	1	Integer	R/CW	Y	xx	Minutes	1 – 60	Default = 15
1842	Demand Subinterval Power	1	Integer	R/CW	Y	xx	Minutes	1 – 60	Default = 1

RO = Read only.
R/CW = Read configure writeable if in a setup session.
NV = Nonvolatile.
① See "How Power Factor is Stored in the Register" on page 122.
② See "How Date and Time Are Stored in Registers" on page 123.

Table A-3: Abbreviated Register List

Reg	Name	Size	Type	Access	NV	Scale	Units	Range	Notes
1843	Demand Sensitivity Power	1	Integer	R/CW	Y	xx	1%	1 – 99	Adjusts the sensitivity of the thermal demand calculation. Default = 90
1844	Predicted Demand Sensitivity Power	1	Integer	R/CW	Y	xx	1.0	1 – 10	Adjusts sensitivity of predicted demand calculation to recent changes in power consumption. Default = 5.
1845	Short Demand Interval Power	1	Integer	R/CW	Y	xx	Seconds	0 – 60	Sets the interval for a running average demand calculation of short duration. Default = 15
1846	Time Elapsed in Interval Power	1	Integer	RO	Y	xx	Seconds	0 – 3,600	
1847	Time Elapsed in Subinterval Power	1	Integer	RO	Y	xx	Seconds	0 – 3,600	
1848	Interval Count Power	1	Integer	RO	Y	xx	1.0	0 – 32,767	Rolls over at 32, 767.
1849	Subinterval Count Power	1	Integer	RO	Y	xx	1.0	0 – 60	Rolls over at interval.
1850	Min/Max Reset DateTime Power	4	DateTime	RO	Y	xx	See Template ②	See Template ②	
1854	Min/Max Reset Count Power	1	Integer	RO	Y	xx	1.0	0 – 32,767	Rolls over at 32,767.
1860	Demand Calculation Mode Input Pulse Metering	1	Integer	R/CW	Y	xx	xxxxxxx	0 – 1024	0 = Thermal Demand (default) 1 = Timed Interval Sliding Block 2 = Timed Interval Block 4 = Timed Interval Rolling Block 8 = Input Synchronized Block 16 = Input Synchronized Rolling Block 32 = Command Synchronized Block 64 = Command Synchronized Rolling Block 128 = Clock Synchronized Block 256 = Clock Synchronized Rolling Block 512 = Slave to Power Demand Interval 1024 = Slave to Incremental Energy Interval
1861	Demand Interval Input Pulse Metering	1	Integer	R/CW	Y	xx	Minutes	1 – 60	Default = 15
1862	Demand Subinterval Input Pulse Metering	1	Integer	R/CW	Y	xx	Minutes	1 – 60	Default = 1
1863	Demand Sensitivity Input Pulse Metering	1	Integer	R/CW	Y	xx	1%	1 – 99	Adjusts the sensitivity of the thermal demand calculation. Default = 90
1865	Short Demand Interval Input Pulse Metering	1	Integer	R/CW	Y	xx	Seconds	0 – 60	Sets the interval for a running average demand calculation of short duration. Default = 15
1866	Time Elapsed in Interval Input Pulse Metering	1	Integer	RO	Y	xx	Seconds	0 – 3,600	

RO = Read only.
R/CW = Read configure writeable if in a setup session.
NV = Nonvolatile.
① See "How Power Factor is Stored in the Register" on page 122.
② See "How Date and Time Are Stored in Registers" on page 123.

Table A-3:Abbreviated Register List

Reg	Name	Size	Type	Access	NV	Scale	Units	Range	Notes
1867	Time Elapsed in Subinterval Input Pulse Metering	1	Integer	RO	Y	xx	Seconds	0 – 3,600	
1868	Interval Count Input Pulse Metering	1	Integer	RO	Y	xx	1.0	0 – 32,767	Rolls over at 32,767.
1869	Subinterval Count Input Pulse Metering	1	Integer	RO	Y	xx	1.0	0 – 60	Rolls over at interval.
1870	Min/Max Reset DateTime Input Pulse Metering	4	DateTime	RO	Y	xx	See Template ②	See Template ②	
1874	Min/Max Reset Count Input Pulse Metering	1	Integer	RO	Y	xx	1.0	0 – 32,767	Rolls over at 32,767.
1880	Demand Calculation Mode Generic Group 1	1	Integer	R/CW	Y	xx	xxxxxxx	0 – 1024	0 = Thermal Demand (default) 1 = Timed Interval Sliding Block 2 = Timed Interval Block 4 = Timed Interval Rolling Block 8 = Input Synchronized Block 16 = Input Synchronized Rolling Block 32 = Command Synchronized Block 64 = Command Synchronized Rolling Block 128 = Clock Synchronized Block 256 = Clock Synchronized Rolling Block 512 = Slave to Power Demand Interval 1024 = Slave to Incremental Energy Interval
1881	Demand Interval Generic Group 1	1	Integer	R/CW	Y	xx	Minutes	1 – 60	Default = 15
1882	Demand Subinterval Generic Group 1	1	Integer	R/CW	Y	xx	Minutes	1 – 60	Default = 1
1883	Demand Sensitivity Generic Group 1	1	Integer	R/CW	Y	xx	1%	1 – 99	Adjusts the sensitivity of the thermal demand calculation. Default = 90
1885	Short Demand Interval Generic Group 1	1	Integer	R/CW	Y	xx	Seconds	0 – 60	Sets the interval for a running average demand calculation of short duration. Default = 15
1886	Time Elapsed in Interval Generic Group 1	1	Integer	RO	Y	xx	Seconds	0 – 3,600	
1887	Time Elapsed in Subinterval Generic Group 1	1	Integer	RO	Y	xx	Seconds	0 – 3,600	
1888	Interval Count Generic Group 1	1	Integer	RO	Y	xx	1.0	0 – 32,767	Rolls over at 32,767.
1889	Subinterval Count Generic Group 1	1	Integer	RO	Y	xx	1.0	0 – 60	Rolls over at interval.
1890	Min/Max Reset DateTime Generic Group 1	4	DateTime	RO	Y	xx	See Template ②	See Template ②	

RO = Read only.
R/CW = Read configure writeable if in a setup session.
NV = Nonvolatile.
① See "How Power Factor is Stored in the Register" on page 122.
② See "How Date and Time Are Stored in Registers" on page 123.

Table A–3:Abbreviated Register List

Reg	Name	Size	Type	Access	NV	Scale	Units	Range	Notes
1894	Min/Max Reset Count Generic Group 1	1	Integer	RO	Y	xx	1.0	0 – 32,767	Rolls over at 32,767.
1900	Demand Calculation Mode Generic Group 2	1	Integer	R/CW	Y	xx	xxxxxxx	0 – 1024	0 = Thermal Demand (default) 1 = Timed Interval Sliding Block 2 = Timed Interval Block 4 = Timed Interval Rolling Block 8 = Input Synchronized Block 16 = Input Synchronized Rolling Block 32 = Command Synchronized Block 64 = Command Synchronized Rolling Block 128 = Clock Synchronized Block 256 = Clock Synchronized Rolling Block 512 = Slave to Power Demand Interval 1024 = Slave to Incremental Energy Interval
1901	Demand Interval Generic Group 2	1	Integer	R/CW	Y	xx	Minutes	1 – 60	Default = 15
1902	Demand Subinterval Generic Group 2	1	Integer	R/CW	Y	xx	Minutes	1 – 60	Default = 1
1903	Demand Sensitivity Generic Group 2	1	Integer	R/CW	Y	xx	1%	1 – 99	Adjusts the sensitivity of the thermal demand calculation. Default = 90
1905	Short Demand Interval Generic Group 2	1	Integer	R/CW	Y	xx	Seconds	0 – 60	Sets the interval for a running average demand calculation of short duration. Default = 15
1906	Time Elapsed in Interval Generic Group 2	1	Integer	RO	Y	xx	Seconds	0 – 3,600	
1907	Time Elapsed in Subinterval Generic Group 2	1	Integer	RO	Y	xx	Seconds	0 – 3,600	
1908	Interval Count Generic Group 2	1	Integer	RO	Y	xx	1.0	0 – 32,767	Rolls over at 32,767.
1909	Subinterval Count Generic Group 2	1	Integer	RO	Y	xx	1.0	0 – 60	Rolls over at interval.
1910	Min/Max Reset DateTime Generic Group 2	4	DateTime	RO	Y	xx	See Template ②	See Template ②	
1914	Min/Max Reset Count Generic Group 2	1	Integer	RO	Y	xx	1.0	0 – 32,767	Rolls over at 32,767.
1920	Demand Forgiveness Duration	1	Integer	R/CW	Y	xx	Seconds	0 – 3,600	Duration of time after a power outage, during which power demand is not calculated
1921	Demand Forgiveness Outage Definition	1	Integer	R/CW	Y	xx	Seconds	0 – 3,600	Duration of time that metered voltage must be lost to be considered a power outage for demand forgiveness
1923	Clock Sync Time of Day	1	Integer	R/CW	Y	xx	Minutes	0 – 1,440	Time of day, in minutes from midnight, to which the demand interval is to be synchronized. Applies to demand intervals configured as Clock Synchronized.

RO = Read only.
R/CW = Read configure writeable if in a setup session.
NV = Nonvolatile.
① See "How Power Factor is Stored in the Register" on page 122.
② See "How Date and Time Are Stored in Registers" on page 123.

Table A-3: Abbreviated Register List

Reg	Name	Size	Type	Access	NV	Scale	Units	Range	Notes
1924	Power Factor Average Over Last Power Demand Interval	1	Integer	RO	Y	xx	0.001	1,000 -100 – 100 (-32,768 if N/A)	
1925	Cumulative Demand Reset DateTime	4	DateTime	RO	Y	xx	See Template ②	See Template ②	
1929	Cumulative Input Pulse Metering Reset DateTime	4	DateTime	RO	Y	xx	See Template ②	See Template ②	
1940	Last Incremental Energy Interval, Real Demand Peak	1	Integer	RO	Y	F	kW/Scale	-32,767 – 32,767	Maximum real 3-phase power demand over the last incremental energy interval
1941	Last Incremental Energy Interval, Real Demand Peak DateTime	4	DateTime	RO	Y	xx	See Template ②	See Template ②	Date/Time of the Real Power Demand peak during the last completed incremental energy interval
1945	Last Incremental Energy Interval, Reactive Demand Peak	1	Integer	RO	Y	F	kVAr/Scale	-32,767 – 32,767	Maximum reactive 3-phase power demand over the last incremental energy interval
1946	Last Incremental Energy Interval, Reactive Demand Peak DateTime	4	DateTime	RO	Y	xx	See Template ②	See Template ②	Date/Time of the Reactive Power Demand peak during the last completed incremental energy interval
1950	Last Incremental Energy Interval, Apparent Demand Peak	1	Integer	RO	Y	F	kVA/Scale	0 – 32,767	Maximum apparent 3-phase power demand over the last incremental energy interval
1951	Last Incremental Energy Interval, Apparent Demand Peak DateTime	4	DateTime	RO	Y	xx	See Template ②	See Template ②	Date/Time of the Apparent Power Demand peak during the last completed incremental energy interval
1960	Last Demand Current, Phase A	1	Integer	RO	N	A	Amperes/Scale	0 – 32,767	Last complete interval
1961	Present Demand Current, Phase A	1	Integer	RO	N	A	Amperes/Scale	0 – 32,767	Present interval
1962	Running Average Demand Current, Phase A	1	Integer	RO	N	A	Amperes/Scale	0 – 32,767	Running average demand calculation of short duration updated every second
1963	Peak Demand Current, Phase A	1	Integer	RO	Y	A	Amperes/Scale	0 – 32,767	
1964	Peak Demand DateTime Current, Phase A	4	DateTime	RO	Y	xx	See Template ②	See Template ②	
1970	Last Demand Current, Phase B	1	Integer	RO	N	A	Amperes/Scale	0 – 32,767	Last complete interval
1971	Present Demand Current, Phase B	1	Integer	RO	N	A	Amperes/Scale	0 – 32,767	Present interval
1972	Running Average Demand Current, Phase B	1	Integer	RO	N	A	Amperes/Scale	0 – 32,767	Running average demand calculation of short duration updated every second
1973	Peak Demand Current Phase B	1	Integer	RO	Y	A	Amperes/Scale	0 – 32,767	

RO = Read only.
R/CW = Read configure writeable if in a setup session.
NV = Nonvolatile.
① See "How Power Factor is Stored in the Register" on page 122.
② See "How Date and Time Are Stored in Registers" on page 123.

Table A-3: Abbreviated Register List

Reg	Name	Size	Type	Access	NV	Scale	Units	Range	Notes
1974	Peak Demand DateTime Current Phase B	4	DateTime	RO	Y	xx	See Template ②	See Template ②	
1980	Last Demand Current, Phase C	1	Integer	RO	N	A	Amperes/Scale	0 – 32,767	Last complete interval
1981	Present Demand Current, Phase C	1	Integer	RO	N	A	Amperes/Scale	0 – 32,767	Present interval
1982	Running Average Demand Current, Phase C	1	Integer	RO	N	A	Amperes/Scale	0 – 32,767	Running average demand calculation of short duration updated every second
1983	Peak Demand Current Phase C	1	Integer	RO	Y	A	Amperes/Scale	0 – 32,767	
1984	Peak Demand DateTime Current Phase C	4	DateTime	RO	Y	xx	See Template ②	See Template ②	
1990	Last Demand Current, Neutral	1	Integer	RO	N	A	Amperes/Scale	0 – 32,767 (-32,768 if N/A)	Last complete interval 4-wire system only
1991	Present Demand Current, Neutral	1	Integer	RO	N	A	Amperes/Scale	0 – 32,767 (-32,768 if N/A)	Present interval 4-wire system only
1992	Running Average Demand Current, Neutral	1	Integer	RO	N	A	Amperes/Scale	0 – 32,767 (-32,768 if N/A)	Running average demand calculation of short duration updated every second 4-wire system only
1993	Peak Demand Current, Neutral	1	Integer	RO	Y	A	Amperes/Scale	0 – 32,767 (-32,768 if N/A)	4-wire system only
1994	Peak Demand DateTime Current, Neutral	4	DateTime	RO	Y	xx	See Template ②	See Template ② (-32,768 if N/A)	4-wire system only
2000	Last Demand Current, 3-Phase Average	1	Integer	RO	N	A	Amperes/Scale	0 – 32,767	Last complete interval
2001	Present Demand Current, 3-Phase Average	1	Integer	RO	N	A	Amperes/Scale	0 – 32,767	Present interval
2002	Running Average Demand Current, 3-Phase Average	1	Integer	RO	N	A	Amperes/Scale	0 – 32,767	Running average demand calculation of short duration updated every second
2003	Peak Demand Current, 3-Phase Average	1	Integer	RO	Y	A	Amperes/Scale	0 – 32,767	
2004	Peak Demand DateTime Current, 3-Phase Average	4	DateTime	RO	Y	xx	See Template ②	See Template ②	
2010	Last Demand Voltage A-B	1	Integer	RO	Y	D	Volts/Scale	0 – 32,767	Last complete interval, updated every sub-interval
2011	Present Demand Voltage A-B	1	Integer	RO	Y	D	Volts/Scale	0 – 32,767	Present interval
2012	Running Average Demand Voltage A-B	1	Integer	RO	Y	D	Volts/Scale	0 – 32,767	Running average demand calculation of short duration – updated every second
2013	Maximum Demand Voltage A-B	1	Integer	RO	Y	D	Volts/Scale	0 – 32,767	

RO = Read only.
R/CW = Read configure writeable if in a setup session.
NV = Nonvolatile.
① See "How Power Factor is Stored in the Register" on page 122.
② See "How Date and Time Are Stored in Registers" on page 123.

Table A-3:Abbreviated Register List

Reg	Name	Size	Type	Access	NV	Scale	Units	Range	Notes
2014	Maximum Demand DateTime Voltage A-B	4	DateTime	RO	Y	xx	See Template ②	See Template ②	
2018	Minimum Demand Voltage A-B	1	Integer	RO	Y	D	Volts/Scale	0 – 32,767	
2019	Minimum Demand DateTime Voltage A-B	4	DateTime	RO	Y	xx	See Template ②	See Template ②	
2025	Last Demand Voltage B-C	1	Integer	RO	Y	D	Volts/Scale	0 – 32,767	Last complete interval, updated every sub-interval
2026	Present Demand Voltage B-C	1	Integer	RO	Y	D	Volts/Scale	0 – 32,767	Present interval
2027	Running Average Demand Voltage B-C	1	Integer	RO	Y	D	Volts/Scale	0 – 32,767	Running average demand calculation of short duration – updated every second
2028	Maximum Demand Voltage B-C	1	Integer	RO	Y	D	Volts/Scale	0 – 32,767	
2029	Maximum Demand DateTime Voltage B-C	4	DateTime	RO	Y	xx	See Template ②	See Template ②	
2033	Minimum Demand Voltage B-C	1	Integer	RO	Y	D	Volts/Scale	0 – 32,767	
2034	Minimum Demand DateTime Voltage B-C	4	DateTime	RO	Y	xx	See Template ②	See Template ②	
2040	Last Demand Voltage C-A	1	Integer	RO	Y	D	Volts/Scale	0 – 32,767	Last complete interval, updated every sub-interval
2041	Present Demand Voltage C-A	1	Integer	RO	Y	D	Volts/Scale	0 – 32,767	Present interval
2042	Running Average Demand Voltage C-A	1	Integer	RO	Y	D	Volts/Scale	0 – 32,767	Running average demand calculation of short duration updated every second
2043	Maximum Demand Voltage C-A	1	Integer	RO	Y	D	Volts/Scale	0 – 32,767	
2044	Maximum Demand DateTime Voltage C-A	4	DateTime	RO	Y	xx	See Template ②	See Template ②	
2048	Minimum Demand Voltage C-A	1	Integer	RO	Y	D	Volts/Scale	0 – 32,767	
2049	Minimum Demand DateTime Voltage C-A	4	DateTime	RO	Y	xx	See Template ②	See Template ②	
2055	Last Demand Voltage L-L Average	1	Integer	RO	Y	D	Volts/Scale	0 – 32,767	Last complete interval, updated every sub-interval
2056	Present Demand Voltage L-L Average	1	Integer	RO	Y	D	Volts/Scale	0 – 32,767	Present interval

RO = Read only.
R/CW = Read configure writeable if in a setup session.
NV = Nonvolatile.
① See “How Power Factor is Stored in the Register” on page 122.
② See “How Date and Time Are Stored in Registers” on page 123.

Table A-3: Abbreviated Register List

Reg	Name	Size	Type	Access	NV	Scale	Units	Range	Notes
2057	Running Average Demand Voltage L-L Average	1	Integer	RO	Y	D	Volts/Scale	0 – 32,767	Running average demand calculation of short duration – updated every second
2058	Maximum Demand Voltage L-L Average	1	Integer	RO	Y	D	Volts/Scale	0 – 32,767	
2059	Maximum Demand DateTime Voltage L-L Average	4	DateTime	RO	Y	xx	See Template ②	See Template ②	
2063	Minimum Demand Voltage L-L Average	1	Integer	RO	Y	D	Volts/Scale	0 – 32,767	
2064	Minimum Demand DateTime Voltage L-L Average	4	DateTime	RO	Y	xx	See Template ②	See Template ②	
2070	Last Demand Voltage A-N	1	Integer	RO	Y	D	Volts/Scale	0 – 32,767 (-32,768 if N/A)	Voltage A-N demand, last complete interval, updated every sub-interval 4-wire system only
2071	Present Demand Voltage A-N	1	Integer	RO	Y	D	Volts/Scale	0 – 32,767 (-32,768 if N/A)	Voltage A-N demand, present interval 4-wire system only
2072	Running Average Demand Voltage A-N	1	Integer	RO	Y	D	Volts/Scale	0 – 32,767 (-32,768 if N/A)	Voltage A-N demand, running average demand calculation of short duration – updated every second 4-wire system only
2073	Maximum Demand Voltage A-N	1	Integer	RO	Y	D	Volts/Scale	0 – 32,767 (-32,768 if N/A)	Voltage A-N maximum demand 4-wire system only
2074	Maximum Demand DateTime Voltage A-N	4	DateTime	RO	Y	xx	See Template ②	See Template ②	Date/Time of Voltage A-N maximum demand 4-wire system only
2078	Minimum Demand Voltage A-N	1	Integer	RO	Y	D	Volts/Scale	0 – 32,767 (-32,768 if N/A)	Voltage A-N minimum demand 4-wire system only
2079	Minimum Demand DateTime Voltage A-N	4	DateTime	RO	Y	xx	See Template ②	See Template ②	Date/Time of Voltage A-N minimum demand 4-wire system only
2085	Last Demand Voltage B-N	1	Integer	RO	Y	D	Volts/Scale	0 – 32,767 (-32,768 if N/A)	Voltage B-N demand, last complete interval, updated every sub-interval (4-wire system only)
2086	Present Demand Voltage B-N	1	Integer	RO	Y	D	Volts/Scale	0 – 32,767 (-32,768 if N/A)	Voltage B-N demand, present interval 4-wire system only
2087	Running Average Demand Voltage B-N	1	Integer	RO	Y	D	Volts/Scale	0 – 32,767 (-32,768 if N/A)	Voltage B-N demand, running average demand calculation of short duration – updated every second 4-wire system only
2088	Maximum Demand Voltage B-N	1	Integer	RO	Y	D	Volts/Scale	0 – 32,767 (-32,768 if N/A)	Voltage B-N maximum demand 4-wire system only

RO = Read only.
R/CW = Read configure writeable if in a setup session.
NV = Nonvolatile.
① See "How Power Factor is Stored in the Register" on page 122.
② See "How Date and Time Are Stored in Registers" on page 123.

Table A-3:Abbreviated Register List

Reg	Name	Size	Type	Access	NV	Scale	Units	Range	Notes
2089	Maximum Demand DateTime Voltage B-N	4	DateTime	RO	Y	xx	See Template ②	See Template ②	Date/Time of Voltage B-N maximum demand 4-wire system only
2093	Minimum Demand Voltage B-N	1	Integer	RO	Y	D	Volts/Scale	0 – 32,767 (-32,768 if N/A)	Voltage B-N minimum demand 4-wire system only
2094	Minimum Demand DateTime Voltage B-N	4	DateTime	RO	Y	xx	See Template ②	See Template ②	Date/Time of Voltage B-N minimum demand 4-wire system only
2100	Last Demand Voltage C-N	1	Integer	RO	Y	D	Volts/Scale	0 – 32,767 (-32,768 if N/A)	Voltage C-N demand, last complete interval, updated every sub-interval (4-wire system only)
2101	Present Demand Voltage C-N	1	Integer	RO	Y	D	Volts/Scale	0 – 32,767 (-32,768 if N/A)	Voltage C-N demand, present interval 4-wire system only
2102	Running Average Demand Voltage C-N	1	Integer	RO	Y	D	Volts/Scale	0 – 32,767 (-32,768 if N/A)	Voltage C-N demand, running average demand calculation of short duration – updated every second 4-wire system only
2103	Maximum Demand Voltage C-N	1	Integer	RO	Y	D	Volts/Scale	0 – 32,767 (-32,768 if N/A)	Voltage C-N maximum demand 4-wire system only
2104	Maximum Demand DateTime Voltage C-N	4	DateTime	RO	Y	xx	See Template ②	See Template ②	Date/Time of Voltage C-N maximum demand 4-wire system only
2108	Minimum Demand Voltage C-N	1	Integer	RO	Y	D	Volts/Scale	0 – 32,767 (-32,768 if N/A)	Voltage C-N minimum demand 4-wire system only
2109	Minimum Demand DateTime Voltage C-N	4	DateTime	RO	Y	xx	See Template ②	See Template ②	Date/Time of Voltage C-N minimum demand 4-wire system only
2130	Last Demand Voltage L-N Average	1	Integer	RO	Y	D	Volts/Scale	0 – 32,767 (-32,768 if N/A)	Voltage L-N Average demand, last complete interval, updated every sub-interval (4-wire system only)
2131	Present Demand Voltage L-N Average	1	Integer	RO	Y	D	Volts/Scale	0 – 32,767 (-32,768 if N/A)	Voltage L-N Average demand, present interval 4-wire system only
2132	Running Average Demand Voltage L-N Average	1	Integer	RO	Y	D	Volts/Scale	0 – 32,767 (-32,768 if N/A)	Voltage L-N Average demand, running average demand calculation of short duration – updated every second 4-wire system only
2133	Maximum Demand Voltage L-N Average	1	Integer	RO	Y	D	Volts/Scale	0 – 32,767 (-32,768 if N/A)	Voltage L-N Average maximum demand 4-wire system only
2134	Maximum Demand DateTime Voltage L-N Average	4	DateTime	RO	Y	xx	See Template ②	See Template ②	Date/Time of Voltage L-N Average maximum demand 4-wire system only
2138	Minimum Demand Voltage L-N Average	1	Integer	RO	Y	D	Volts/Scale	0 – 32,767 (-32,768 if N/A)	Voltage L-N Average minimum demand 4-wire system only

RO = Read only.

R/CW = Read configure writeable if in a setup session.

NV = Nonvolatile.

① See "How Power Factor is Stored in the Register" on page 122.

② See "How Date and Time Are Stored in Registers" on page 123.

Table A-3: Abbreviated Register List

Reg	Name	Size	Type	Access	NV	Scale	Units	Range	Notes
2139	Minimum Demand DateTime Voltage L-N Average	4	DateTime	RO	Y	xx	See Template ②	See Template ②	Date/Time of Voltage L-N Average minimum demand 4-wire system only
2150	Last Demand Real Power, 3- Phase Total	1	Integer	RO	N	F	kW/Scale	-32,767 – 32,767	3-Phase total present real power demand for last completed demand interval – updated every sub-interval
2151	Present Demand Real Power, 3- Phase Total	1	Integer	RO	N	F	kW/Scale	-32,767 – 32,767	3-Phase total present real power demand for present demand interval
2152	Running Average Demand Real Power, 3- Phase Total	1	Integer	RO	N	F	kW/Scale	-32,767 – 32,767	Updated every second
2153	Predicted Demand Real Power, 3- Phase Total	1	Integer	RO	N	F	kW/Scale	-32,767 – 32,767	Predicted real power demand at the end of the present interval
2154	Peak Demand Real Power, 3- Phase Total	1	Integer	RO	Y	F	kW/Scale	-32,767 – 32,767	
2155	Peak Demand DateTime Real Power, 3- Phase Total	4	DateTime	RO	Y	xx	See Template ②	See Template ②	
2159	Cumulative Demand Real Power, 3- Phase Total	2	Long	RO	Y	F	kW/Scale	-2147483648 – 2147483647	
2161	Power Factor, Average @ Peak Demand, Real Power	1	Integer	RO	Y	xx	0.001	1,000 -100 to 100 (-32,768 if N/A) ①	Average True Power Factor at the time of the Peak Real Demand
2162	Power Demand, Reactive @ Peak Demand, Real Power	1	Integer	RO	Y	F	kVAr/Scale	-32,767 – 32,767	Reactive Power Demand at the time of the Peak Real Demand
2163	Power Demand, Apparent @ Peak Demand, Real Power	1	Integer	RO	Y	F	kVA/Scale	0 – 32,767	Apparent Power Demand at the time of the Peak Real Demand
2165	Last Demand Reactive Power, 3-Phase Total	1	Integer	RO	N	F	kVAr /Scale	-32,767 – 32,767	3-Phase total present reactive power demand for last completed demand interval – updated every sub-interval
2166	Present Demand Reactive Power, 3-Phase Total	1	Integer	RO	N	F	kVAr /Scale	-32,767 – 32,767	3-Phase total present real power demand for present demand interval
2167	Running Average Demand Reactive Power, 3-Phase Total	1	Integer	RO	N	F	kVAr /Scale	-32,767 – 32,767	3-Phase total present reactive power demand, running average demand calculation of short duration – updated every second
2168	Predicted Demand Reactive Power, 3-Phase Total	1	Integer	RO	N	F	kVAr /Scale	-32,767 – 32,767	Predicted reactive power demand at the end of the present interval

RO = Read only.
R/CW = Read configure writeable if in a setup session.
NV = Nonvolatile.
① See "How Power Factor is Stored in the Register" on page 122.
② See "How Date and Time Are Stored in Registers" on page 123.

Table A-3:Abbreviated Register List

Reg	Name	Size	Type	Access	NV	Scale	Units	Range	Notes
2169	Peak Demand Reactive Power, 3-Phase Total	1	Integer	RO	Y	F	kVAr /Scale	-32,767 – 32,767	
2170	Peak Demand DateTime Reactive Power, 3-Phase Total	4	DateTime	RO	Y	xx	See Template ②	See Template ②	
2174	Cumulative Demand Reactive Power, 3-Phase Total	2	Long	RO	Y	F	kVAr /Scale	-2147483648 – 2147483647	
2176	Power Factor, Average @ Peak Demand, Reactive Power	1	Integer	RO	Y	xx	0.001	1,000 -100 to 100 (-32,768 if N/A) ①	Average True Power Factor at the time of the Peak Reactive Demand
2177	Power Demand, Real @ Peak Demand, Reactive Power	1	Integer	RO	Y	F	kW/Scale	-32,767 – 32,767	Real Power Demand at the time of the Peak Reactive Demand
2178	Power Demand, Apparent @ Peak Demand, Reactive Power	1	Integer	RO	Y	F	kVA/Scale	0 – 32,767	Apparent Power Demand at the time of the Peak Reactive Demand
2180	Last Demand Apparent Power 3-Phase Total	1	Integer	RO	N	F	kVA /Scale	-32,767 – 32,767	3-Phase total present apparent power demand for last completed demand interval – updated every sub-interval
2181	Present Demand Apparent Power, 3-Phase Total	1	Integer	RO	N	F	kVA /Scale	-32,767 – 32,767	3-Phase total present apparent power demand for present demand interval
2182	Running Average Demand Apparent Power, 3-Phase Total	1	Integer	RO	N	F	kVA /Scale	-32,767 – 32,767	3-Phase total present apparent power demand, running average demand calculation of short duration – updated every second
2183	Predicted Demand Apparent Power, 3-Phase Total	1	Integer	RO	N	F	kVA /Scale	-32,767 – 32,767	Predicted apparent power demand at the end of the present interval
2184	Peak Demand Apparent Power, 3-Phase Total	1	Integer	RO	Y	F	kVA /Scale	-32,767 – 32,767	3-Phase total peak apparent power demand peak
2185	Peak Demand DateTime Apparent Power, 3-Phase Total	4	DateTime	RO	Y	xx	See Template ②	See Template ②	Date/Time of 3-Phase peak apparent power demand
2189	Cumulative Demand Apparent Power, 3-Phase Total	2	Long	RO	Y	F	kVA /Scale	-2,147,483,648 – 2,147,483,647	Cumulative Demand, Apparent Power
2191	Power Factor, Average @ Peak Demand, Apparent Power	1	Integer	RO	Y	xx	0.001	1,000 -100 to 100 (-32,768 if N/A) ①	Average True Power Factor at the time of the Peak Apparent Demand
2192	Power Demand, Real @ Peak Demand, Apparent Power	1	Integer	RO	Y	F	kW/Scale	-32,767 – 32,767	Real Power Demand at the time of the Peak Apparent Demand
2193	Power Demand, Reactive @ Peak Demand, Apparent Power	1	Integer	RO	Y	F	kVAr/Scale	0 – 32,767	Reactive Power Demand at the time of the Peak Apparent Demand

RO = Read only.
R/CW = Read configure writeable if in a setup session.
NV = Nonvolatile.
① See "How Power Factor is Stored in the Register" on page 122.
② See "How Date and Time Are Stored in Registers" on page 123.

Table A-3: Abbreviated Register List

Reg	Name	Size	Type	Access	NV	Scale	Units	Range	Notes
2200	Unit Code Input Channel #1	1	Integer	R/CW	Y	xx	xxxxxx	-32,767 – 32,767	Used by software Default = 0
2201	Scale Code Input Channel #1	1	Integer	R/CW	Y	xx	xxxxxx	-3 – 3	Scale code (power of 10) used by software Default = 0
2202	Last Demand Input Channel #1	1	Integer	RO	Y	xx	xxxxxx	0 – 32,767	Demand last complete interval Default = 0
2203	Present Demand Input Channel #1	1	Integer	RO	Y	xx	xxxxxx	0 – 32,767	
2204	Running Average Demand Input Channel #1	1	Integer	RO	Y	xx	xxxxxx	0 – 32,767	Updated every second
2205	Peak Demand Input Channel #1	1	Integer	RO	Y	xx	xxxxxx	0 – 32,767	
2206	Peak Demand Date/Time Input Channel #1	4	DateTime	RO	Y	xx	See Template ②	See Template ②	
2210	Minimum Demand Input Channel #1	1	Integer	RO	Y	xx	xxxxxx	0 – 32,767	
2211	Minimum Demand Date/ Time Input Channel #1	4	DateTime	RO	Y	xx	See Template ②	See Template ②	
2215	Cumulative Usage Input Channel #1	4	Mod10	RO	Y	xx	xxxxxx	(1)	
2220	Input Channel #2	20							Same as registers 2200 – 2219 except for Channel #2
2240	Input Channel #3	20							Same as registers 2200 – 2219 except for Channel #3
2260	Input Channel #4	20							Same as registers 2200 – 2219 except for Channel #4
2280	Input Channel #5	20							Same as registers 2200 – 2219 except for Channel #5
2300	Input Channel #6	20							Same as registers 2200 – 2219 except for Channel #6
2320	Input Channel #7	20							Same as registers 2200 – 2219 except for Channel #7
2340	Input Channel #8	20							Same as registers 2200 – 2219 except for Channel #8
2360	Input Channel #9	20							Same as registers 2200 – 2219 except for Channel #9
2380	Input Channel #10	20							Same as registers 2200 – 2219 except for Channel #10

Note:

(1) 0 – 9,999,999,999,999,999

2400	Input Register Generic Channel #1	1	Integer	R/CW	Y	xx	xxxxxx	xxxxxx	Register selected for generic demand calculation
2401	Unit Code Generic Channel #1	1	Integer	R/CW	Y	xx	xxxxxx	-32,767 – 32,767	Used by software
2402	Scale Code Generic Channel #1	1	Integer	R/CW	Y	xx	xxxxxx	-3 – 3	

RO = Read only.

R/CW = Read configure writeable if in a setup session.

NV = Nonvolatile.

① See "How Power Factor is Stored in the Register" on page 122.

② See "How Date and Time Are Stored in Registers" on page 123.

Table A-3:Abbreviated Register List

Reg	Name	Size	Type	Access	NV	Scale	Units	Range	Notes
2403	Last Demand Generic Channel #1	1	Integer	RO	Y	xx	xxxxxx	0 – 32,767	
2404	Present Demand Generic Channel #1	1	Integer	RO	Y	xx	xxxxxx	0 – 32,767	
2405	Running Average Demand Generic Channel #1	1	Integer	RO	Y	xx	xxxxxx	0 – 32,767	Updated every second
2406	Peak Demand Generic Channel #1	1	Integer	RO	Y	xx	xxxxxx	0 – 32,767	
2407	Peak Demand Date/Time Generic Channel #1	4	DateTime	RO	Y	xx	See Template ②	See Template ②	
2411	Minimum Demand Generic Channel #1	1	Integer	RO	Y	xx	xxxxxx	0 – 32,767	
2412	Minimum Demand Date/Time Generic Channel #1	4	DateTime	RO	Y	xx	See Template ②	See Template ②	
2420	Generic Channel #2	20							Same as registers 2400 – 2419 except for Channel #2
2440	Generic Channel #3	20							Same as registers 2400 – 2419 except for Channel #3
2460	Generic Channel #4	20							Same as registers 2400 – 2419 except for Channel #4
2480	Generic Channel #5	20							Same as registers 2400 – 2419 except for Channel #5
2500	Generic Channel #6	20							Same as registers 2400 – 2419 except for Channel #6
2520	Generic Channel #7	20							Same as registers 2400 – 2419 except for Channel #7
2540	Generic Channel #8	20							Same as registers 2400 – 2419 except for Channel #8
2560	Generic Channel #9	20							Same as registers 2400 – 2419 except for Channel #9
2580	Generic Channel #10	20							Same as registers 2400 – 2419 except for Channel #10
2600	Generic Channel #11	20							Same as registers 2400 – 2419 except for Channel #11
2620	Generic Channel #12	20							Same as registers 2400 – 2419 except for Channel #12
2640	Generic Channel #13	20							Same as registers 2400 – 2419 except for Channel #13
2660	Generic Channel #14	20							Same as registers 2400 – 2419 except for Channel #14
2680	Generic Channel #15	20							Same as registers 2400 – 2419 except for Channel #15
2700	Generic Channel #16	20							Same as registers 2400 – 2419 except for Channel #16

RO = Read only.
R/CW = Read configure writeable if in a setup session.
NV = Nonvolatile.
① See "How Power Factor is Stored in the Register" on page 122.
② See "How Date and Time Are Stored in Registers" on page 123.

Table A–3:Abbreviated Register List

Reg	Name	Size	Type	Access	NV	Scale	Units	Range	Notes
2720	Generic Channel #17	20							Same as registers 2400 – 2419 except for Channel #17
2740	Generic Channel #18	20							Same as registers 2400 – 2419 except for Channel #18
2760	Generic Channel #19	20							Same as registers 2400 – 2419 except for Channel #19
2780	Generic Channel #20	20							Same as registers 2400 – 2419 except for Channel #20
Phase Extremes									
2800	Current, Highest Phase Value	1	Integer	RO	N	A	Amperes/Scale	0 – 32,767	Highest value of Phases A, B, C or N
2801	Current, Lowest Phase Value	1	Integer	RO	N	A	Amperes/Scale	0 – 32,767	Lowest value of Phases A, B, C or N
2802	Voltage, L-L, Highest Value	1	Integer	RO	N	D	Volts/Scale	0 – 32,767	Highest value of Phases A-B, B-C or C-A
2803	Voltage, L-L, Lowest Value	1	Integer	RO	N	D	Volts/Scale	0 – 32,767	Lowest value of Phases A-B, B-C or C-A
2804	Voltage, L-N, Highest Value	1	Integer	RO	N	D	Volts/Scale	0 – 32,767 (-32,768 if N/A)	Highest value of Phases A-N, B-N or C-N 4-wire system only
2805	Voltage, L-N, Lowest Value	1	Integer	RO	N	D	Volts/Scale	0 – 32,767 (-32,768 if N/A)	Lowest value of Phases A-N, B-N or C-N 4-wire system only
System Configuration									
3000	Circuit Monitor Label	2	Character	R/CW	Y	xx	xxxxxxx	xxxxxxx	
3002	Circuit Monitor Nameplate	8	Character	R/CW	Y	xx	xxxxxxx	xxxxxxx	
3014	Circuit Monitor Present Operating System Firmware Revision Level	1	Integer	RO	N	xx	xxxxxxx	0x0000 – 0xFFFF	
3034	Present Date/Time	4	DateTime	RO	N	xx	See Template ②	See Template ②	
3039	Last Unit Restart Date Time	4	DateTime	RO	Y	xx	See Template ②	See Template ②	
3043	Number of Metering System Restarts	1	Integer	RO	Y	xx	1	0 – 32,767	
3044	Number of Control Power Failures	1	Integer	RO	Y	xx	1	0 – 32,767	
3045	Date/Time of Last Control Power Failure	4	DateTime	RO	Y	xx	See Template ②	See Template ②	

RO = Read only.
R/CW = Read configure writeable if in a setup session.
NV = Nonvolatile.
① See "How Power Factor is Stored in the Register" on page 122.
② See "How Date and Time Are Stored in Registers" on page 123.

Table A-3:Abbreviated Register List

Reg	Name	Size	Type	Access	NV	Scale	Units	Range	Notes
3050	Self-Test Results	1	Bitmap	RO	N	xx	xxxxxxx	0x0000 – 0xFFFF	0 = Normal; 1 = Error Bit 00 = Is set to "1" if any failure occurs Bit 01 = RTC failure Bit 02 = MCF UART #1 failure Bit 03 = MCF UART #2 failure Bit 04 = PLD UART failure Bit 05 = Metering Collection overrun failure Bit 06 = Metering Process 0.1 overrun failure Bit 07 = Metering Process 1.0 overrun failure Bit 08 = Disk-on-Chip failure Bit 09 = Display failure Bit 10 = CV Module failure Bit 11 = Aux Plug EEPROM failure Bit 12 = Flash Memory failure Bit 13 = Dram Memory failure Bit 14 = Simtek Memory failure Bit 15 = RTC Memory failure
3051	Self Test Results	1	Bitmap	RO	N	xx	xxxxxxx	0x0000 – 0xFFFF	0 = Normal; 1 = Error Bit 00 = Aux IO failure Bit 01 = Option Slot A module failure Bit 02 = Option Slot B module failure Bit 03 = IOX module failure Bit 04 = Not used Bit 05 = Bit 06 = Bit 07 = Bit 08 = OS Create failure Bit 09 = OS Queue overrun failure Bit 10 = Not used Bit 11 = Not used Bit 12 = Bit 13 = Systems shut down due to continuous reset Bit 14 = Unit in Download, Condition A Bit 15 = Unit in Download, Condition B
3052	Configuration Modified	1	Integer	RO	Y	xx	xxxxxxx	0x0000 – 0xFFFF	Used by sub-systems to indicate that a value used within that system has been internally modified 0 = No modifications; 1 = Modifications Bit 00 = Summary bit Bit 01 = Metering System Bit 02 = Communications System Bit 03 = Alarm System Bit 04 = File System Bit 05 = Auxiliary IO System Bit 06 = Display System
3053	Installed Log Memory	1	Integer	RO	Y	xx	Clusters	0 – 65,535	
3054	Free Log Memory	1	Integer	RO	Y	xx	Clusters	0 – 65,535	
3055	Log Memory Cluster Size	1	Integer	RO	Y	xx	Bytes	0 – 65,535	
3056	Programmed Disk On Chip Version Number	1	Integer	R/W	N	xx	xxxxxxx	0x0000 – 0xFFFF	
3058	Real Time Clock Factory Calibration	1	Integer	RO	Y	xx	ppm	-63 – 126	(-) = Slow down (+) = Speed up

RO = Read only.
R/CW = Read configure writeable if in a setup session.
NV = Nonvolatile.
① See "How Power Factor is Stored in the Register" on page 122.
② See "How Date and Time Are Stored in Registers" on page 123.

Table A-3: Abbreviated Register List

Reg	Name	Size	Type	Access	NV	Scale	Units	Range	Notes
3059	Real Time Clock Field Calibration	1	Integer	R/CW	Y	xx	ppm	-63 – 126	(-) = Slow down (+) = Speed up
3061	Installed Log Memory	1	Integer	RO	Y	xx	Mbytes	0 – 65,535	
3073	Installed Option—Slot A	1	Integer	RO	N	xx	xxxxxxx	0 – 16	0 = Not Installed 1 = IOC44 2 = Reserved 3 = Reserved 4 = Reserved 5 = Reserved 6 = Ethernet Option Module
3093	Present Month	1	Integer	RO	N	xx	Months	1 – 12	
3094	Present Day	1	Integer	RO	N	xx	Days	1 – 31	
3095	Present Year	1	Integer	RO	N	xx	Years	2,000 – 2,043	
3096	Present Hour	1	Integer	RO	N	xx	Hours	0 – 23	
3097	Present Minute	1	Integer	RO	N	xx	Minutes	0 – 59	
3098	Present Second	1	Integer	RO	N	xx	Seconds	0 – 59	
3099	Day of Week	1	Integer	RO	N	xx	1.0	1 – 7	Sunday = 1

Current and Voltage Module Configuration

3138	CT Ratio, Phase A Correction Factor	1	Integer	R/CW	Y	xx	0.00001	-20,000 – 20,000	Default = 0
3139	CT Ratio, Phase B Correction Factor	1	Integer	R/CW	Y	xx	0.00001	-20,000 – 20,000	Default = 0
3140	CT Ratio, Phase C Correction Factor	1	Integer	R/CW	Y	xx	0.00001	-20,000 – 20,000	Default = 0
3141	CT Ratio, Neutral Correction Factor	1	Integer	R/CW	Y	xx	0.00001	-20,000 – 20,000	Default = 0
3142	PT Ratio, Phase A Correction Factor	1	Integer	R/CW	Y	xx	0.00001	-20,000 – 20,000	Default = 0
3143	PT Ratio, Phase B Correction Factor	1	Integer	R/CW	Y	xx	0.00001	-20,000 – 20,000	Default = 0
3144	PT Ratio, Phase C Correction Factor	1	Integer	R/CW	Y	xx	0.00001	-20,000 – 20,000	Default = 0
3145	Neutral-Ground Correction Factor	1	Integer	R/CW	Y	xx	0.00001	-20,000 – 20,000	Default = 0
3150	Field Calibration Date/Time	4	DateTime	R/CW	Y	xx	See Template ②	See Template ②	
3154	Phase A Current Field Calibration Coefficient	1	Integer	R/CW	Y	xx	0.00001	-20,000 – 20,000	Default = 0
3155	Phase B Current Field Calibration Coefficient	1	Integer	R/CW	Y	xx	0.00001	-20,000 – 20,000	Default = 0
3156	Phase C Current Field Calibration Coefficient	1	Integer	R/CW	Y	xx	0.00001	-20,000 – 20,000	Default = 0
3157	Neutral Current Field Calibration Coefficient	1	Integer	R/CW	Y	xx	0.00001	-20,000 – 20,000	Default = 0

RO = Read only.
R/CW = Read configure writeable if in a setup session.
NV = Nonvolatile.
① See "How Power Factor is Stored in the Register" on page 122.
② See "How Date and Time Are Stored in Registers" on page 123.

Table A-3: Abbreviated Register List

Reg	Name	Size	Type	Access	NV	Scale	Units	Range	Notes
3158	Phase A Voltage Field Calibration Coefficient	1	Integer	R/CW	Y	xx	0.00001	-20,000 – 20,000	Default = 0
3159	Phase B Voltage Field Calibration Coefficient	1	Integer	R/CW	Y	xx	0.00001	-20,000 – 20,000	Default = 0
3160	Phase C Voltage Field Calibration Coefficient	1	Integer	R/CW	Y	xx	0.00001	-20,000 – 20,000	Default = 0
3161	Neutral-Ground Voltage Field Calibration Coefficient	1	Integer	R/CW	Y	xx	0.00001	-20,000 – 20,000	Default = 0
3170	CT Phase Shift Correction @ 1 amp	1	Integer	R/CW	Y	xx	xxxxxxx	-1,000 – 1,000	For user instrumentation, in the range of -10° to +10°. A negative shifts in the lag direction. Default = 0
3171	CT Phase Shift Correction @ 5 Amperes	1	Integer	R/CW	Y	xx	xxxxxxx	-1,000 – 1,000	For user instrumentation, in the range of -10° to +10°. A negative shifts in the lag direction. Default = 0

Metering Configuration

3200	Metering System Type	1	Integer	R/CW	Y	xx	1.0	30, 31, 40, 41, 42, 43	30 = 3PH3W2CT 31 = 3PH3W3CT 40 = 3PH4W3CT (default) 41 = 3PH4W4CT 42 = 3PH4W3CT2PT 43 = 3PH4W4CT2PT
3201	CT Ratio, 3-Phase Primary	1	Integer	R/CW	Y	xx	1.0	1 – 32,767	Default = 5
3202	CT Ratio, 3-Phase Secondary	1	Integer	R/CW	Y	xx	1.0	1, 5	Default = 5
3203	CT Ratio, Neutral Primary	1	Integer	R/CW	Y	xx	1.0	1 – 32,767	Default = 5
3204	CT Ratio, Neutral Secondary	1	Integer	R/CW	Y	xx	1.0	1, 5	Default = 5
3205	PT Ratio, 3-Phase Primary	1	Integer	R/CW	Y	xx	1.0	1 – 32,767	Default = 120
3206	PT Ratio, 3-Phase Primary Scale Factor	1	Integer	R/CW	Y	xx	1.0	-1 – 2	Default = 0 -1 = Direct Connect
3207	PT Ratio, 3-Phase Secondary	1	Integer	R/CW	Y	xx	1.0	100, 110, 115, 120	Default = 120
3208	Nominal System Frequency	1	Integer	R/CW	Y	xx	Hz	50, 60, 400	Default = 60
3209	Scale A – 3 Phase Amperes	1	Integer	R/CW	Y	xx	1.0	-2 – 1	Power of 10 Default = 0
3210	Scale B – Neutral Amperes	1	Integer	R/CW	Y	xx	1.0	-2 – 1	Power of 10 Default = 0
3211	Scale C – Ground Amperes	1	Integer	R/CW	Y	xx	1.0	-2 – 1	Power of 10 Default = 0
3212	Scale D – 3 Phase Volts	1	Integer	R/CW	Y	xx	1.0	-1 – 2	Power of 10 Default = 0

RO = Read only.
R/CW = Read configure writeable if in a setup session.
NV = Nonvolatile.
① See “How Power Factor is Stored in the Register” on page 122.
② See “How Date and Time Are Stored in Registers” on page 123.

Table A-3:Abbreviated Register List

Reg	Name	Size	Type	Access	NV	Scale	Units	Range	Notes
3227	Operating Mode Parameters	1	Bitmap	R/CW	Y	xx	Binary	0x0000 – 0x0FFF	Default = 0 Bit 00 = Reserved Bit 01 = Reactive Energy & Demand Accumulation 0 = Fund. Only ; 1 = Harmonics Included Bit 02 = VAR/PF Sign Convention 0 = Standard IEEE Convention 1 = CM1 Convention Bit 03 = Reserved Bit 04 = Reserved Bit 05 = Reserved Bit 06 = Conditional Energy Accumulation Control 0 = Inputs; 1 = Command Bit 07 = Reserved Bit 08 = Display Setup 0 = Enabled; 1 = Disabled Bit 09 = Normal Phase Rotation 0 = ABC; 1 = CBA Bit 10 = Large or Small THD 0 = THD; 1 = thd Bit 11 = Generate Phase Loss Voltage 0 = Disabled; 1 = Enabled
3228	Phase Rotation Direction	1	Integer	RO	N	xx	1.0	0 – 1	0 = ABC; 1 = CBA
3229	Incremental Energy Interval	1	Integer	R/CW	Y	xx	Minutes	0 – 1440	Default = 60 0 = Continuous Accumulation
3230	Incremental Energy Interval Start Time	1	Integer	R/CW	Y	xx	Minutes	0 – 1440	Minutes from midnight Default = 0
3231	Incremental Energy Interval End Time	1	Integer	R/CW	Y	xx	Minutes	0 – 1440	Minutes from midnight Default = 1440
3232	Energy Accumulation Mode	1	Integer	R/CW	Y	xx	1.0	0 – 1	0 = Absolute (default) 1 = Signed
3233	Peak Current Demand Over Last Year	1	Integer	R/W	Y	xx	Amperes	0 – 32,767	Entered by the user for use in calculation of Total Demand Distortion. 0 = Calculation not performed (default)
3240	Harmonic Quantity Selection	1	Integer	R/W	Y	xx	1.0	0 – 3	0 = Disabled 1 = Harmonic magnitudes only (default) 2 = Harmonic magnitudes and angles
3241	Harmonic Magnitude Format	1	Integer	R/CW	Y	xx	1.0	0 – 1	0 = % of Fundamental (default) 1 = % of RMS
3242	Harmonic Refresh Interval	1	Integer	R/CW	Y	xx	Seconds	10 – 60	Default = 30
3243	Time Remaining Until Harmonic Refresh	1	Integer	R/W	N	xx	Seconds	10 – 60	The user may write to this register to stretch the hold time.
3245	Harmonic Report Status	1	Integer	RO	N	xx	1.0	0 – 1	0 = Processing (default) 1 = Holding

RO = Read only.
R/CW = Read configure writeable if in a setup session.
NV = Nonvolatile.
① See "How Power Factor is Stored in the Register" on page 122.
② See "How Date and Time Are Stored in Registers" on page 123.

Table A-3: Abbreviated Register List

Reg	Name	Size	Type	Access	NV	Scale	Units	Range	Notes
3254	Metering System Diagnostic Summary	1	Bitmap	RO	N	xx	Binary	0x0000 – 0xFFFF	0 = Normal; 1 = Error Bit 00 = Summary Bit (On if any other bit is on) Bit 01 = Configuration Error Bit 02 = Scaling Error Bit 03 = Phase Loss Bit 04 = Wiring Error Bit 05 = Incremental Energy may be incorrect due to meter reset Bit 06 = External Demand Sync Timeout
3255	Metering System Configuration Error Summary	1	Bitmap	RO	N	xx	Binary	0x0000 – 0xFFFF	0 = Normal; 1 = Error Bit 00 = Summary Bit (On if any other bit is on) Bit 01 = Logical Configuration Error Bit 02 = Demand System Configuration Error Bit 03 = Energy System Configuration Error Bit 04 = Average/Min/Max System Configuration Error Bit 05 = Metering Configuration Error Bit 06 = Flicker System Configuration Error
3257	Wiring Error Detection 1	1	Bitmap	RO	N	xx	Binary	0x0000 – 0xFFFF	0 = Normal; 1 = Error Bit 00 = Summary Bit (On if any other bit is on) Bit 01 = Wiring Check Aborted Bit 02 = System type setup error Bit 03 = Frequency out of range Bit 04 = No voltage Bit 05 = Voltage imbalance Bit 06 = Not enough load to check connections Bit 07 = Check meter configured for direct connect Bit 08 = All CT reverse polarity Bit 09 = Reserved Bit 10 = Reserved Bit 11 = Reserved Bit 12 = Reserved Bit 13 = Reserved Bit 14 = Phase rotation not as expected Bit 15 = Negative kW is usually abnormal
3258	Wiring Error Detection 2	1	Bitmap	RO	N	xx	Binary	0x0000 – 0xFFFF	0 = Normal; 1 = Error Bit 00 = Van magnitude error Bit 01 = Vbn magnitude error Bit 02 = Vcn magnitude error Bit 03 = Vab magnitude error Bit 04 = Vbc magnitude error Bit 05 = Vca magnitude error Bit 06 = Van angle not as expected Bit 07 = Vbn angle not as expected Bit 08 = Vcn angle not as expected Bit 09 = Vab angle not as expected Bit 10 = Vbc angle not as expected Bit 11 = Vca angle not as expected Bit 12 = Vbn is reversed polarity Bit 13 = Vcn is reversed polarity Bit 14 = Vbc is reversed polarity Bit 15 = Vca is reversed polarity

RO = Read only.
R/CW = Read configure writeable if in a setup session.
NV = Nonvolatile.
① See "How Power Factor is Stored in the Register" on page 122.
② See "How Date and Time Are Stored in Registers" on page 123.

Table A-3: Abbreviated Register List

Reg	Name	Size	Type	Access	NV	Scale	Units	Range	Notes
3259	Wiring Error Detection 3	1	Bitmap	RO	N	xx	Binary	0x0000 – 0xFFFF	0 = Normal; 1 = Error Bit 00 = Move VTa to VTb Bit 01 = Move VTb to VTc Bit 02 = Move VTc to VTa Bit 03 = Move VTa to VTc Bit 04 = Move VTb to VTa Bit 05 = Move VTc to VTb Bit 06 = Reserved Bit 07 = Reserved Bit 08 = Reserved Bit 09 = Reserved Bit 10 = Ia is < 1% of CT Bit 11 = Ib is < 1% of CT Bit 12 = Ic is < 1% of CT Bit 13 = Ia angle not in expected range Bit 14 = Ib angle not in expected range Bit 15 = Ic angle not in expected range
3260	Wiring Error Detection 4	1	Bitmap	RO	N	xx	Binary	0x0000 – 0xFFFF	0 = Normal; 1 = Error Bit 00 = CTa reversed polarity Bit 01 = CTb reversed polarity Bit 02 = CTc reversed polarity Bit 03 = Reserved Bit 04 = Move CTa to CTb Bit 05 = Move CTb to CTc Bit 06 = Move CTc to CTa Bit 07 = Move CTa to CTc Bit 08 = Move CTb to CTa Bit 09 = Move CTc to CTb Bit 10 = Move CTa to CTb & reverse polarity Bit 11 = Move CTb to CTc & reverse polarity Bit 12 = Move CTc to CTa & reverse polarity Bit 13 = Move CTa to CTc & reverse polarity Bit 14 = Move CTb to CTa & reverse polarity Bit 15 = Move CTc to CTb & reverse polarity
3261	Scaling Error	1	Bitmap	RO	N	xx	Binary	0x0000 – 0x003F	Indicates potential over range due to scaling error 0 = Normal; 1 = Error Bit 00 = Summary Bit (On if any other bit is on) Bit 01 = Scale A – Phase Current Error Bit 02 = Scale B – Neutral Current Error Bit 03 = Scale C – Ground Current Error Bit 04 = Scale D – Phase Voltage Error Bit 05 = Scale E – Neutral Voltage Error Bit 06 = Scale F – Power Error

RO = Read only.
 R/CW = Read configure writeable if in a setup session.
 NV = Nonvolatile.
 ① See "How Power Factor is Stored in the Register" on page 122.
 ② See "How Date and Time Are Stored in Registers" on page 123.

Table A-3: Abbreviated Register List

Reg	Name	Size	Type	Access	NV	Scale	Units	Range	Notes
3262	Phase Loss Bitmap	1	Bitmap	RO	N	xx	Binary	0x0000 – 0x007F (-32,768 if N/A)	0 = OK; 1 = Phase Loss Bit 00 = Summary Bit (On if any other bit is on) Bit 01 = Voltage Phase A Bit 02 = Voltage Phase B Bit 03 = Voltage Phase C Bit 04 = Current Phase A Bit 05 = Current Phase B Bit 06 = Current Phase C This register is controlled by the voltage and current phase loss alarms. These alarms must be configured and enabled for this register to be populated.
3270	Minimum/ Maximum Reset Date/Time	4	DateTime	RO	Y	xx	See Template ②	See Template ②	
3274	Accumulated Energy Reset Date/Time	4	DateTime	RO	Y	xx	See Template ②	See Template ②	
3278	Conditional Energy Reset Date/Time	4	DateTime	RO	Y	xx	See Template ②	See Template ②	
3282	Incremental Energy Reset Date/Time	4	DateTime	RO	Y	xx	See Template ②	See Template ②	
3286	Input Metering Accumulation Reset Date/Time	4	DateTime	RO	Y	xx	See Template ②	See Template ②	
3290	Accumulated Energy Preset Date/Time	4	DateTime	RO	Y	xx	See Template ②	See Template ②	
3299	Average/Min/ Max Log Number of Data Items	1	Integer	RO	Y	xx	1	25	Number of Quantities for which Average/Min/Max calculations are made and logged.
3300	Average/Min/ Max Log Interval	1	Integer	R/CW	Y	xx	Minute	1 – 1440	Must be evenly divisible into 1440. Default = 60
3301	Average/Min/ Max Log Channel #1 Meter Register	1	Integer	R/CW	Y	xx	xxxxxx	0, 1100 – 2999	Default = 1100 Current, Phase A 0 = No calculation for this channel
3302	Average/Min/ Max Log Channel #2 Meter Register	1	Integer	R/CW	Y	xx	xxxxxx	0, 1100 – 2999	Default = 1101 Current, Phase B 0 = No calculation for this channel
3303	Average/Min/ Max Log Channel #3 Meter Register	1	Integer	R/CW	Y	xx	xxxxxx	0, 1100 – 2999	Default = 1102 Current, Phase C 0 = No calculation for this channel
3304	Average/Min/ Max Log Channel #4 Meter Register	1	Integer	R/CW	Y	xx	xxxxxx	0, 1100 – 2999	Default = 1103 Current, Neutral 0 = No calculation for this channel
3305	Average/Min/ Max Log Channel #5 Meter Register	1	Integer	R/CW	Y	xx	xxxxxx	0, 1100 – 2999	Default = 1104 Current, Ground 0 = No calculation for this channel

RO = Read only.
R/CW = Read configure writeable if in a setup session.
NV = Nonvolatile.
① See "How Power Factor is Stored in the Register" on page 122.
② See "How Date and Time Are Stored in Registers" on page 123.

Table A–3:Abbreviated Register List

Reg	Name	Size	Type	Access	NV	Scale	Units	Range	Notes
3306	Average/Min/ Max Log Channel #6 Meter Register	1	Integer	R/CW	Y	xx	xxxxxx	0, 1100 – 2999	Default = 1120 Voltage, A-B 0 = No calculation for this channel
3307	Average/Min/ Max Log Channel #7 Meter Register	1	Integer	R/CW	Y	xx	xxxxxx	0, 1100 – 2999	Default = 1121 Voltage B-C 0 = No calculation for this channel
3308	Average/Min/ Max Log Channel #8 Meter Register	1	Integer	R/CW	Y	xx	xxxxxx	0, 1100 – 2999	Default = 1122 Voltage C-A 0 = No calculation for this channel
3309	Average/Min/ Max Log Channel #9 Meter Register	1	Integer	R/CW	Y	xx	xxxxxx	0, 1100 – 2999	Default = 0 0 = No calculation for this channel
3310	Average/Min/ Max Log Channel #10 Meter Register	1	Integer	R/CW	Y	xx	xxxxxx	0, 1100 – 2999	Default = 1143 Real Power, Total 0 = No calculation for this channel
3311	Average/Min/ Max Log Channel #11 Meter Register	1	Integer	R/CW	Y	xx	xxxxxx	0, 1100 – 2999	Default = 1147 Reactive Power, Total 0 = No calculation for this channel
3312	Average/Min/ Max Log Channel #12 Meter Register	1	Integer	R/CW	Y	xx	xxxxxx	0, 1100 – 2999	Default = 1151 Apparent Power, Total 0 = No calculation for this channel
3313	Average/Min/ Max Log Channel #13 Meter Register	1	Integer	R/CW	Y	xx	xxxxxx	0, 1100 – 2999	Default = 1163 True Power Factor, Total 0 = No calculation for this channel
3314	Average/Min/ Max Log Channel #14 Meter Register	1	Integer	R/CW	Y	xx	xxxxxx	0, 1100 – 2999	Default = 1171 Displacement Power Factor, Total 0 = No calculation for this channel
3315	Average/Min/ Max Log Channel #15 Meter Register	1	Integer	R/CW	Y	xx	xxxxxx	0, 1100 – 2999	Default = 1207 THD/thd Voltage Phase A-N 0 = No calculation for this channel
3316	Average/Min/ Max Log Channel #16 Meter Register	1	Integer	R/CW	Y	xx	xxxxxx	0, 1100 – 2999	Default = 1208 THD/thd Voltage Phase B-N 0 = No calculation for this channel
3317	Average/Min/ Max Log Channel #17 Meter Register	1	Integer	R/CW	Y	xx	xxxxxx	0, 1100 – 2999	Default = 1209 THD/thd Voltage Phase C-N 0 = No calculation for this channel
3318	Average/Min/ Max Log Channel #18 Meter Register	1	Integer	R/CW	Y	xx	xxxxxx	0, 1100 – 2999	Default = 1211 THD/thd Voltage Phase A-B 0 = No calculation for this channel
3319	Average/Min/ Max Log Channel #19 Meter Register	1	Integer	R/CW	Y	xx	xxxxxx	0, 1100 – 2999	Default = 1212 THD/thd Voltage Phase B-C 0 = No calculation for this channel
3320	Average/Min/ Max Log Channel #20 Meter Register	1	Integer	R/CW	Y	xx	xxxxxx	0, 1100 – 2999	Default = 1213 THD/thd Voltage Phase C-A 0 = No calculation for this channel

RO = Read only.
R/CW = Read configure writeable if in a setup session.
NV = Nonvolatile.
①See "How Power Factor is Stored in the Register" on page 122.
②See "How Date and Time Are Stored in Registers" on page 123.

Table A-3: Abbreviated Register List

Reg	Name	Size	Type	Access	NV	Scale	Units	Range	Notes
3321	Average/Min/Max Log Channel #21 Meter Register	1	Integer	R/CW	Y	xx	xxxxxx	0, 1100 – 2999	Default = 2150 Last Demand, Real Power, 3-Phase Total 0 = No calculation for this channel
3322	Average/Min/Max Log Channel #22 Meter Register	1	Integer	R/CW	Y	xx	xxxxxx	0, 1100 – 2999	Default = 2165 Last Demand, Reactive Power, 3-Phase Total 0 = No calculation for this channel
3323	Average/Min/Max Log Channel #23 Meter Register	1	Integer	R/CW	Y	xx	xxxxxx	0, 1100 – 2999	Default = 2180 Last Demand, Apparent Power, 3-Phase Total 0 = No calculation for this channel
3324	Average/Min/Max Log Channel #24 Meter Register	1	Integer	R/CW	Y	xx	xxxxxx	0, 1100 – 2999	Default = 0 0 = No calculation for this channel
3325	Average/Min/Max Log Channel #25 Meter Register	1	Integer	R/CW	Y	xx	xxxxxx	0, 1100 – 2999	Default = 0 0 = No calculation for this channel
3350	Discrete Input Point Assignment to Discrete Input Status Bitmap Bit 00	1	Integer	R/CW	Y	xx	xxxxxx	0 – 66	0 = none Default = 3 (Dig In A-S1)
3351	Discrete Input Point Assignment to Discrete Input Status Bitmap Bit 01	1	Integer	R/CW	Y	xx	xxxxxx	0 – 66	0 = none Default = 4 (Dig In A-S2)
3352	Discrete Input Point Assignment to Discrete Input Status Bitmap Bit 02	1	Integer	R/CW	Y	xx	xxxxxx	0 – 66	0 = none Default = 5 (Dig In A-S3)
3353	Discrete Input Point Assignment to Discrete Input Status Bitmap Bit 03	1	Integer	R/CW	Y	xx	xxxxxx	0 – 66	0 = none Default = 6 (Dig In A-S4)

Communication

3400	RS-485 Comm Port (M/S), Protocol	1	Integer	R/CW	Y	xx	xxxxxxx	0 – 2	0 = Modbus (default) 1 = Jbus
3401	RS-485 Comm Port (M/S), Address	1	Integer	R/CW	Y	xx	xxxxxxx	0 – 255	Valid Addresses: (Default = 1) Modbus: 0 – 247 Jbus: 0 – 255
3402	RS-485 Comm Port (M/S), Baud Rate	1	Integer	R/CW	Y	xx	xxxxxxx	0 – 5	0 = 1200 1 = 2400 2 = 4800 3 = 9600 (default) 4 = 19200 5 = 38400
3403	RS-485 Comm Port (M/S), Parity	1	Integer	R/CW	Y	xx	xxxxxxx	0 – 2	0 = Even (default) 1 = Odd 2 = None

RO = Read only.
R/CW = Read configure writeable if in a setup session.
NV = Nonvolatile.
① See "How Power Factor is Stored in the Register" on page 122.
② See "How Date and Time Are Stored in Registers" on page 123.

Table A-3: Abbreviated Register List

Reg	Name	Size	Type	Access	NV	Scale	Units	Range	Notes
3404	RS-485 Comm Port (M/S), Master/Slave Mode Selection	1	Integer	R/CW	Y	xx	xxxxxxx	0 – 1	0 = Slave (default) 1 = Master
3405	RS-485 Comm Port (M), Time-Out Time	1	Integer	R/CW	Y	xx	xxxxxxx	1 – 60	Time-Out in seconds when communicating as a master
3410	RS-485 Comm Port (M/S), Packets To This Unit	1	Integer	RO	Y	xx	xxxxxxx	0 – 32,767	Number of valid messages addressed to this unit
3411	RS-485 Comm Port (S), Packets To Other Units	1	Integer	RO	Y	xx	xxxxxxx	0 – 32,767	Number of valid messages addressed to other units
3412	RS-485 Comm Port (M/S), Packets With Invalid Address	1	Integer	RO	Y	xx	xxxxxxx	0 – 32,767	Number of messages received with invalid address
3413	RS-485 Comm Port (M/S), Packets With Bad CRC	1	Integer	RO	Y	xx	xxxxxxx	0 – 32,767	Number of messages received with bad CRC
3414	RS-485 Comm Port (M/S), Packets With Error	1	Integer	RO	Y	xx	xxxxxxx	0 – 32,767	Number of messages received with errors
3415	RS-485 Comm Port (M/S), Packets With Illegal Opcode	1	Integer	RO	Y	xx	xxxxxxx	0 – 32,767	Number of messages received with an illegal opcode
3416	RS-485 Comm Port (M/S), Packets With Illegal Register	1	Integer	RO	Y	xx	xxxxxxx	0 – 32,767	Number of messages received with an illegal register
3417	RS-485 Comm Port (S), Invalid Write Responses	1	Integer	RO	Y	xx	xxxxxxx	0 – 32,767	Number of invalid write responses
3418	RS-485 Comm Port (M/S), Packets With Illegal Counts	1	Integer	RO	Y	xx	xxxxxxx	0 – 32,767	Number of messages received with an illegal count
3419	RS-485 Comm Port (M/S), Packets With Frame Error	1	Integer	RO	Y	xx	xxxxxxx	0 – 32,767	Number of messages received with a frame error
3420	RS-485 Comm Port (S), Broadcast Messages	1	Integer	RO	Y	xx	xxxxxxx	0 – 32,767	Number of broadcast messages received
3421	RS-485 Comm Port (M/S), Number Of Exceptions	1	Integer	RO	Y	xx	xxxxxxx	0 – 32,767	Number of exception replies
3422	RS-485 Comm Port (M/S), Messages With Good CRC	1	Integer	RO	Y	xx	xxxxxxx	0 – 32,767	Number of messages received with a good CRC

RO = Read only.
R/CW = Read configure writeable if in a setup session.
NV = Nonvolatile.
① See "How Power Factor is Stored in the Register" on page 122.
② See "How Date and Time Are Stored in Registers" on page 123.

Table A-3: Abbreviated Register List

Reg	Name	Size	Type	Access	NV	Scale	Units	Range	Notes
3423	RS-485 Comm Port (M/S), Modbus Event Counter	1	Integer	RO	Y	xx	xxxxxxx	0 – 32,767	Modbus Event Counter
3424	RS-485 Comm Port (M), Time Out	1	Integer	RO	Y	xx	xxxxxxx	0 – 32,767	Message failed due to excessive response time from the internal comm. server

RO = Read only.
R/CW = Read configure writeable if in a setup session.
NV = Nonvolatile.
① See “How Power Factor is Stored in the Register” on page 122.
② See “How Date and Time Are Stored in Registers” on page 123.

Table A-4: Abbreviated Register List for I/O Status

Reg	Name	Size	Type	Access	NV	Scale	Units	Range	Notes
4001	Discrete Input Status Option Slot A	1	Bitmap	RO	N	xx	xxxxxxx	0x0000 – 0xFFFF	0 = Off, 1 = On Bit 00 = On/Off Status of IO Point 3 (A01) Bit 01 = On/Off Status of IO Point 4 (A02) Bit 02 = On/Off Status of IO Point 5 (A03) Bit 03 = On/Off Status of IO Point 6 (A04) Bit 04 = On/Off Status of IO Point 7 (A05) Bit 05 = On/Off Status of IO Point 8 (A06) Bit 06 = On/Off Status of IO Point 9 (A07) Bit 07 = On/Off Status of IO Point 10 (A08) Bit 08 = On/Off Status of IO Point 11 (A09) Bit 09 = On/Off Status of IO Point 12 (A10) Bit 10 = On/Off Status of IO Point 13 (A11) Bit 11 = On/Off Status of IO Point 14 (A12) Bit 12 = On/Off Status of IO Point 15 (A13) Bit 13 = On/Off Status of IO Point 16 (A14) Bit 14 = On/Off Status of IO Point 17 (A15) Bit 15 = On/Off Status of IO Point 18 (A16)
4010	IO System Diagnostic Summary	1	Bitmap	RO	N	xx	xxxxxxx	0x0000 – 0x007F	0 = OK, 1 = Error Bit 00 = Summary bit Bit 01 = IO Error – Standard Bit 02 = IO Error – Option Slot A Bit 03 = Not used Bit 04 = Not used Bit 05 = Not used Bit 06 = Time Sync Signal Error
4011	IO Module Health Status Standard IO	1	Bitmap	RO	N	xx	xxxxxxx	0x0000 – 0x000F	0 = OK, 1 = Error Bit 00 = Module error summary Bit 01 = Point error summary Bit Bit 02 = Module removed while meter running Bit 03 = Module change failed validation
4012	IO Module Health Status Option Slot A	1	Bitmap	RO	N	xx	xxxxxxx	0x0000 – 0x000F	0 = OK, 1 = Error Bit 00 = Module error summary Bit 01 = Point error summary Bit Bit 02 = Module removed while meter running Bit 03 = Module change failed validation

RO = Read only.
R/CW = Read configure writeable if in a setup session.
NV = Nonvolatile.

Table A-4: Abbreviated Register List for I/O Status

Reg	Name	Size	Type	Access	NV	Scale	Units	Range	Notes
4016	Time Sync Signal Health Status	1	Bitmap	RO	N	xx	xxxxxxx	0x0000 – 0xFFFF	0 = OK, 1 = Error Bit 00 = Summary Bit, time sync signal fatal error Bit 01 = Lost time sync signal Bit 02 = Summary Bit, invalid data Bit 03 = Data value out of range Bit 04 = Parity error for minute Bit 05 = Parity error for hour Bit 06 = Parity error for month/day/year Bit 07 = Bit 20 not = 1 Bit 08 = Framing error occurred in last minute Bit 09 = Reserved Bit 10 = Reserved Bit 11 = Reserved Bit 12 = Good time sync signal received Bit 13 = Reserve antenna in use Bit 14 = DST warning Bit 15 = DST in effect
4017	GPS Time Sync Accuracy	1	Integer	RO	N	xx	millisecond	0 – 1,000	GPS Time Sync Accuracy
4021	Present Module Type Option Slot A	1	Integer	RO	N	xx	xxxxxxx	0 – 6	0 = Not Installed 1 = IOC44 2 = Reserved 3 = Reserved 4 = Reserved 5 = Reserved 6 = Ethernet Option Module
4200	Discrete Output/Alarm Table	100	Integer	R/CW	Y	xx	xxxxxxx	0 – 17081	Table of discrete output/alarm associations. Upper byte is IO Point Number (1 – 66). Lower byte is Alarm Index Number (1 – 185).
4300	IO Point Number 1 Standard Discrete Output (S01)	30							Refer to Discrete Output template below.
4360	IO Point Number 3 (A01)	30							Register contents depends on IO Point Type. Refer to templates below.
4390	IO Point Number 4 (A02)	30							Register contents depends on IO Point Type. Refer to templates below.
4420	IO Point Number 5 (A03)	30							Register contents depends on IO Point Type. Refer to templates below.
4450	IO Point Number 6 (A04)	30							Register contents depends on IO Point Type. Refer to templates below.
4480	IO Point Number 7 (A05)	30							Register contents depends on IO Point Type. Refer to templates below.
4510	IO Point Number 8 (A06)	30							Register contents depends on IO Point Type. Refer to templates below.
4540	IO Point Number 9 (A07)	30							Register contents depends on IO Point Type. Refer to templates below.
4570	IO Point Number 10 (A08)	30							Register contents depends on IO Point Type. Refer to templates below.
4600	IO Point Number 11 (A09)	30							Register contents depends on IO Point Type. Refer to templates below.

RO = Read only.
R/CW = Read configure writeable if in a setup session.
NV = Nonvolatile.

Table A-4: Abbreviated Register List for I/O Status

Reg	Name	Size	Type	Access	NV	Scale	Units	Range	Notes
4630	IO Point Number 12 (A10)	30							Register contents depends on IO Point Type. Refer to templates below.
4660	IO Point Number 13 (A11)	30							Register contents depends on IO Point Type. Refer to templates below.
4690	IO Point Number 14 (A12)	30							Register contents depends on IO Point Type. Refer to templates below.
4720	IO Point Number 15 (A13)	30							Register contents depends on IO Point Type. Refer to templates below.
4750	IO Point Number 16 (A14)	30							Register contents depends on IO Point Type. Refer to templates below.
4780	IO Point Number 17 (A15)	30							Register contents depends on IO Point Type. Refer to templates below.
4810	IO Point Number 18 (A16)	30							Register contents depends on IO Point Type. Refer to templates below.

Digital Input Template

Base	IO Point Type	1	Integer	R/CW	Y	xx	xxxxxxx	100 – 199	<p>First digit (1) indicates point is discrete input Second digit indicates module type 0 = Generic discrete input 1 = DI120AC Pluggable Module 2 = DI240AC Pluggable Module 3 = DI32DC Pluggable Module Third digit indicates input type 1 = AC 2 = DC</p>
Base +1	IO Point Label	8	Character	R/W	Y	xx	xxxxxxx	ASCII	16 Characters
Base +9	Discrete Input Operating Mode	1	Integer	R/CW	Y	xx	xxxxxxx	0 – 3	<p>0 = Normal (default) 1 = Demand Interval Sync Pulse 2 = Time Sync 3 = Conditional Energy Control</p> <p>Only one Time Sync input and one Conditional Energy Control are allowed. If the user attempts to configure more than one of each of these modes, the lowest IO Point Number will take precedence. The modes of the other points will be set to default. Time sync input signal must be pulse duration method (PDM) as from the Modicon GPS Receiver (470 GPS 001 00).</p>
Base +10	Demand Interval Sync System Assignments	1	Bitmap	R/CW	Y	xx	xxxxxxx	0x0000 – 0x003F	<p>Bitmap indicating Demand System(s) to which input is assigned. (Default = 0x003F)</p> <p>Bit 00 = Power Demand Bit 01 = Current Demand Bit 02 = Voltage Demand Bit 03 = Input Metering Demand Bit 04 = Generic Demand 1 Bit 05 = Generic Demand 2</p> <p>Only one Demand Sync Pulse per Demand System is allowed. If the user attempts to configure more than one input for each system, the lowest IO Point Number will take precedence. The corresponding bits of the other points will be set to 0.</p>
Base +11	Discrete Input Options	1	Bitmap	R/CW	Y	xx	xxxxxxx	0x0000 – 0x0001	<p>Default = 0 Bit 00 = Debounce time (0 = 5msec, 1 = 50msec)</p>

RO = Read only.
R/CW = Read configure writeable if in a setup session.
NV = Nonvolatile.

Table A-4: Abbreviated Register List for I/O Status

Reg	Name	Size	Type	Access	NV	Scale	Units	Range	Notes
Base +14	Metering Pulse Channel Assignments	1	Bitmap	R/CW	Y	xx	xxxxxxx	0x0000 – 0x03FF	Default = 0 Bit 00 = Channel 1 Bit 01 = Channel 2 Bit 02 = Channel 3 Bit 03 = Channel 4 Bit 04 = Channel 5 Bit 05 = Channel 6 Bit 06 = Channel 7 Bit 07 = Channel 8 Bit 08 = Channel 9 Bit 09 = Channel 10
Base +15	Metering Pulse Weight Demand	1	Integer	R/CW	Y	xx	1.0	1– 32,767	Pulse weight associated with the change of state of the input. Used for demand metering. (Default = 1)
Base +16	Metering Pulse Scale Factor Demand	1	Integer	R/CW	Y	xx	1.0	-3 – 3	Pulse weight scale factor (power of 10) to apply to metering pulse weight. Used for demand metering. (Default = 0)
Base +17	Metering Pulse Weight Consumption	1	Integer	R/CW	Y	xx	1.0	1– 32,767	Pulse weight associated with the change of state of the input. Used for consumption metering. (Default = 1)
Base +18	Metering Pulse Scale Factor Consumption	1	Integer	R/CW	Y	xx	1.0	-3 – 3	Pulse weight scale factor (power of 10) to apply to metering pulse weight. Used for consumption metering. (Default = 0)
Base +22	IO Point Diagnostic Bitmap	1	Bitmap	RO	Y	xx	xxxxxxx	0x0000 – 0xFFFF	0 = OK, 1 = Error Bit 00 = IO Point diagnostic summary Bit 01 = Configuration invalid – default value used
Base +25	Discrete Input On/Off Status	1	Integer	RO	Y	xx	xxxxxxx	0 – 1	0 = Off 1 = On
Base +26	Count	2	Mod10	RO	Y	xx	xxxxxxx	0 – 99,999,999	Number of times input has transitioned from Off to On
Base +28	On Time	2	Mod10	RO	Y	xx	Seconds	0 – 99,999,999	Duration that discrete input has been On

Digital Output Template

Base	IO Point Type	1	Integer	R/CW	Y	xx	xxxxxxx	200 – 299	First digit (2) indicates point is discrete output Second digit indicates module type 0 = Generic discrete output 1 = DO120AC Pluggable Module 2 = DO200DC Pluggable Module 3 = DO240AC Pluggable Module 4 = DO60DC Pluggable Module Third digit indicates output type 1 = solid state relay 2 = electromechanical relay
Base +1	IO Point Label	8	Character	R/W	Y	xx	xxxxxxx	ASCII	16 Characters
Base +9	Discrete Output Operating Mode	1	Integer	R/CW	Y	xx	xxxxxxx	0 – 11	0 = Normal (default) 1 = Latched 2 = Timed 3 = Absolute kWh pulse 4 = Absolute kVARh pulse 5 = kVAh pulse 6 = kWh In pulse 7 = kVARh In pulse 8 = kWh out pulse 9 = kVARh out pulse 10 = Register-based pulse (future) 11 = End of power demand interval
Base +10	On Time For Timed Mode	1	Integer	R/CW	Y	xx	Seconds	1 – 32,767	The time for the output to remain energized when the output is in timed mode or end of power demand interval. (Default = 1)

RO = Read only.
R/CW = Read configure writeable if in a setup session.
NV = Nonvolatile.

Table A-4: Abbreviated Register List for I/O Status

Reg	Name	Size	Type	Access	NV	Scale	Units	Range	Notes
Base +11	Pulse Weight	1	Integer	R/CW	Y	xx	kWh/ Pulse kVARh/ Pulse kVAh/ Pulse in 100ths	1 – 32,767	Specifies the kWh, kVARh and kVAh per pulse for output when in these modes. (Default = 1)
Base +12	Internal/External Control	1	Integer	R/W	Y	xx	xxxxxxx	0 – 1	0 = Internal Control 1 = External Control (default)
Base +13	Normal/Override Control	1	Integer	R/W	Y	xx	xxxxxxx	0 – 1	0 = Normal Control (default) 1 = Override Control
Base +21	State of Discrete Output at Reset	1	Integer	RO	Y	xx	xxxxxxx	0 – 1	Indicates On/Off state of the discrete output when meter reset/shutdown occurs
Base +22	IO Point Diagnostic Bitmap	1	Bitmap	RO	Y	xx	xxxxxxx	0x0000 – 0x000F	0 = OK, 1 = Error Bit 00 = IO Point diagnostic summary Bit 01 = Configuration invalid – default value used Bit 02 = Discrete output energy pulse – time between transitions exceeds 30 seconds Bit 03 = Discrete output energy pulse – time between transitions limited to 20 milliseconds
Base +25	Discrete Output On/Off Status	1	Integer	RO	Y	xx	xxxxxxx	0 – 1	0 = Off 1 = On
Base +26	Count	2	Mod10	RO	Y	xx	xxxxxxx	0 – 99,999,999	Number of times output has transitioned from OFF to ON
Base +28	On Time	2	Mod10	RO	Y	xx	Seconds	0 – 99,999,999	Duration that discrete output has been ON

Analog Input Template

Base	IO Point Type	1	Integer	R/CW	Y	xx	xxxxxxx	300 – 399	First digit (3) indicates point is analog input Second digit indicates the range of analog I/O values (used without units) 0 = 0 – 1 1 = 0 – 5 2 = 0 – 10 3 = 0 – 20 4 = 1 – 5 5 = 4 – 20 6 = -5 – 5 7 = -10 – 10 8 = -100 – 100 9 = User defined (values default to 0) Third digit indicates the digital resolution of the I/O hardware. The user must select from one of these standard ranges. 0 = 8-Bit, unipolar 1 = 10-Bit, unipolar 2 = 12-Bit, unipolar 3 = 14-Bit, unipolar 4 = 16-Bit, unipolar 5 = 16-Bit, bipolar with sign 6 = reserved 7 = reserved 8 = reserved 9 = reserved
Base +1	IO Point Label	8	Character	R/W	Y	xx	xxxxxxx	ASCII	16 Characters
Base +9	Units Code	1	Integer	R/CW	Y	xx	xxxxxxx	0 – 99	Placeholder for a code used by software to identify the SI units of the analog input being metered, i.e. kW, V, etc.
Base +10	Scale Code	1	Integer	R/CW	Y	xx	xxxxxxx	-3 – 3	Placeholder for the scale code (power of 10) used by software to place the decimal point.

RO = Read only.
R/CW = Read configure writeable if in a setup session.
NV = Nonvolatile.

Table A-4: Abbreviated Register List for I/O Status

Reg	Name	Size	Type	Access	NV	Scale	Units	Range	Notes
Base +11	Range Select	1	Integer	R/CW	Y	xx	xxxxxxx	0 – 1	Analog input gain select. Applies only to Option Module AIO42 (Future). 0 = Use calibration constants associated with voltage (default) 1 = Use calibration constants associated with current which were determined using the 250 Ohm internal resistor
Base +12	Analog Input Minimum	1	Integer	R/CW	Y	xx	xxxxxxx	0 – ±32,767	Minimum value of the scaled register value for the analog input. (Only if Metering Register Number is not 0.)
Base +13	Analog Input Maximum	1	Integer	R/CW	Y	xx	xxxxxxx	0 – ±32,767	Maximum value of the scaled register value for the analog input. (Only if Metering Register Number is not 0.)
Base +14	Lower Limit Analog Value	1	Integer	R/CW	Y	xx	xxxxxxx	0 – ±327	Lower limit of the analog input value. Default value based on IO Point Type.
Base +15	Upper Limit Analog Value	1	Integer	R/CW	Y	xx	xxxxxxx	0 – ±327	Upper limit of the analog input value. Default value based on IO Point Type.
Base +16	Lower Limit Register Value	1	Integer	R/CW	Y	xx	xxxxxxx	0 – ±32,767	Lower limit of the register value associated with the lower limit of the analog input value.
Base +17	Upper Limit Register Value	1	Integer	R/CW	Y	xx	xxxxxxx	0 – ±32,767	Upper limit of the register value associated with the upper limit of the analog input value.
Base +18	Metering Register Number	1	Integer	R/CW	Y	xx	xxxxxxx	0, 1190 – 1199	Register where Present Scaled Value is copied. This register is included in the Min/Max determination for metered values.
Base +19	User Gain Adjustment	1	Integer	R/CW	Y	xx	0.0001	8,000 – 12,000	Analog input user gain adjustment in 100ths of a percent. Default = 10,000.
Base +20	User Offset Adjustment	1	Integer	R/CW	Y	xx	xxxxxxx	0 – ±30,000	Analog input user offset adjustment in Bits of digital resolution. Default = 0.
Base +22	IO Point Diagnostic Bitmap	1	Bitmap	RO	Y	xx	xxxxxxx	0x0000 – 0x0007	0 = OK, 1 = Error Bit 00 = IO Point diagnostic summary Bit 01 = Configuration invalid – default value used Bit 02 = M-Bus communications error
Base +23	Lower Limit Digital Value	1	Integer	RO	Y	xx	xxxxxxx	0 – ±32,767	Lower limit of the digital value associated with the lower limit of the analog input value. Value based on IO Point Type.
Base +24	Upper Limit Digital Value	1	Integer	RO	Y	xx	xxxxxxx	0 – ±32,767	Upper limit of the digital value associated with the upper limit of the analog input value. Value based on IO Point Type.
Base +25	Present Raw Value	1	Integer	RO	Y	xx	xxxxxxx	0 – ±32,767	Raw digital value read from analog input.
Base +26	Present Scaled Value	1	Integer	RO	Y	xx	xxxxxxx	0 – ±32,767	Raw value corrected by calibration gain and offset adjustments and scaled based on range of register values.
Base +27	Calibration Offset	1	Integer	RO	Y	xx	xxxxxxx	0 – ±32,767	Analog input offset adjustment
Base +28	Calibration Gain (Voltage)	1	Integer	RO	Y	xx	0.0001	8,000 – 12,000	Analog input gain adjustment
Base +29	Calibration Gain (Current)	1	Integer	RO	Y	xx	0.0001	8,000 – 12,000	Analog input gain adjustment

RO = Read only.
R/CW = Read configure writeable if in a setup session.
NV = Nonvolatile.

Table A-5: Registers for Alarms

Reg	Name	Size	Type	Access	NV	Scale	Units	Range	Notes
10000	P1 Alarm Queue	10	Integer	RO	Y	xx	xxxxxxx	1 – 185	Queue of last ten active priority 1 alarms
10010	P1 Acknowledge Status	1	Bitmap	RO	Y	xx	Binary	0x0000 – 0x03FF	Acknowledge status for each of the P1 alarms in the queue
10011	Active Alarm Map	12	Bitmap	RO	Y	xx	Binary	0x0000 – 0xFFFF	0 = Inactive, 1 = Active Bit00 = Alarm #01 Bit01 = Alarm #02 etc.
10023	Active Alarm Status	1	Bitmap	RO	Y	xx	Binary	0x0000 – 0x000F	Bit00 = 1 if any priority 1-3 alarm is active Bit01 = 1 if a “High” (1) priority alarm is active Bit02 = 1 if a “Medium” (2) priority alarm is active Bit03 = 1 if a “Low” (3) priority alarm is active
10024	Latched Active Alarm Status	1	Bitmap	R/W	N	xx	Binary	0x0000 – 0x000F	Latched Active Alarms: (from the last time the register was cleared) Bit00 = 1 if any priority 1-3 alarm is active Bit01 = 1 if a “High” (1) priority alarm is active Bit02 = 1 if a “Medium” (2) priority alarm is active Bit03 = 1 if a “Low” (3) priority alarm is active
10025	Total Counter	1	Integer	R/W	Y	xx	1.0	0 – 32,767	Total alarm counter, including all priorities 1, 2 and 3
10026	P3 Counter	1	Integer	R/W	Y	xx	1.0	0 – 32,767	Low alarm counter, all priority 3s
10027	P2 Counter	1	Integer	R/W	Y	xx	1.0	0 – 32,767	Medium alarm counter, all priority 2s
10028	P1 Counter	1	Integer	R/W	Y	xx	1.0	0 – 32,767	High alarm counter, all priority 1s
10029	Pickup Mode Selection	12	Bitmap	R/W	Y	xx	Binary	0x0 – 0xFFFF	Selection of absolute or relative pickup test for each of the alarm positions (if applicable, based on type) Alarm #01 is least significant bit in register 10041 0 = Absolute (default) 1 = Relative Bit00 = Alarm #01 Bit01 = Alarm #02 etc.
10041	Number Of Samples In Relative Threshold Average	1	Integer	R/CW	Y	xx	1.0	5 – 30	Number of 1-second update intervals used to compute the RMS average value used in relative pickup alarms (Default = 30)
10115	Alarm Position #001 Counter	1	Integer	RO	Y	xx	1.0	0 – 32,767	Standard Speed Alarm Position #001
10116	Alarm Position #002 Counter	1	Integer	RO	Y	xx	1.0	0 – 32,767	Standard Speed Alarm Position #002
10117	Alarm Position #003 Counter	1	Integer	RO	Y	xx	1.0	0 – 32,767	Standard Speed Alarm Position #003
10118	Alarm Position #004 Counter	1	Integer	RO	Y	xx	1.0	0 – 32,767	Standard Speed Alarm Position #004
10119	Alarm Position #005 Counter	1	Integer	RO	Y	xx	1.0	0 – 32,767	Standard Speed Alarm Position #005
10120	Alarm Position #006 Counter	1	Integer	RO	Y	xx	1.0	0 – 32,767	Standard Speed Alarm Position #006
10121	Alarm Position #007 Counter	1	Integer	RO	Y	xx	1.0	0 – 32,767	Standard Speed Alarm Position #007
10122	Alarm Position #008 Counter	1	Integer	RO	Y	xx	1.0	0 – 32,767	Standard Speed Alarm Position #008
10123	Alarm Position #009 Counter	1	Integer	RO	Y	xx	1.0	0 – 32,767	Standard Speed Alarm Position #009
10124	Alarm Position #010 Counter	1	Integer	RO	Y	xx	1.0	0 – 32,767	Standard Speed Alarm Position #010

RO = Read only.
R/CW = Read configure writeable if in a setup session.
NV = Nonvolatile.

Table A-5:Registers for Alarms

Reg	Name	Size	Type	Access	NV	Scale	Units	Range	Notes
10125	Alarm Position #011 Counter	1	Integer	RO	Y	xx	1.0	0 – 32,767	Standard Speed Alarm Position #011
10126	Alarm Position #012 Counter	1	Integer	RO	Y	xx	1.0	0 – 32,767	Standard Speed Alarm Position #012
10127	Alarm Position #013 Counter	1	Integer	RO	Y	xx	1.0	0 – 32,767	Standard Speed Alarm Position #013
10128	Alarm Position #014 Counter	1	Integer	RO	Y	xx	1.0	0 – 32,767	Standard Speed Alarm Position #014
10129	Alarm Position #015 Counter	1	Integer	RO	Y	xx	1.0	0 – 32,767	Standard Speed Alarm Position #015
10130	Alarm Position #016 Counter	1	Integer	RO	Y	xx	1.0	0 – 32,767	Standard Speed Alarm Position #016
10131	Alarm Position #017 Counter	1	Integer	RO	Y	xx	1.0	0 – 32,767	Standard Speed Alarm Position #017
10132	Alarm Position #018 Counter	1	Integer	RO	Y	xx	1.0	0 – 32,767	Standard Speed Alarm Position #018
10133	Alarm Position #019 Counter	1	Integer	RO	Y	xx	1.0	0 – 32,767	Standard Speed Alarm Position #019
10134	Alarm Position #020 Counter	1	Integer	RO	Y	xx	1.0	0 – 32,767	Standard Speed Alarm Position #020
10135	Alarm Position #021 Counter	1	Integer	RO	Y	xx	1.0	0 – 32,767	Standard Speed Alarm Position #021
10136	Alarm Position #022 Counter	1	Integer	RO	Y	xx	1.0	0 – 32,767	Standard Speed Alarm Position #022
10137	Alarm Position #023 Counter	1	Integer	RO	Y	xx	1.0	0 – 32,767	Standard Speed Alarm Position #023
10138	Alarm Position #024 Counter	1	Integer	RO	Y	xx	1.0	0 – 32,767	Standard Speed Alarm Position #024
10139	Alarm Position #025 Counter	1	Integer	RO	Y	xx	1.0	0 – 32,767	Standard Speed Alarm Position #025
10140	Alarm Position #026 Counter	1	Integer	RO	Y	xx	1.0	0 – 32,767	Standard Speed Alarm Position #026
10141	Alarm Position #027 Counter	1	Integer	RO	Y	xx	1.0	0 – 32,767	Standard Speed Alarm Position #027
10142	Alarm Position #028 Counter	1	Integer	RO	Y	xx	1.0	0 – 32,767	Standard Speed Alarm Position #028
10143	Alarm Position #029 Counter	1	Integer	RO	Y	xx	1.0	0 – 32,767	Standard Speed Alarm Position #029
10144	Alarm Position #030 Counter	1	Integer	RO	Y	xx	1.0	0 – 32,767	Standard Speed Alarm Position #030
10145	Alarm Position #031 Counter	1	Integer	RO	Y	xx	1.0	0 – 32,767	Standard Speed Alarm Position #031
10146	Alarm Position #032 Counter	1	Integer	RO	Y	xx	1.0	0 – 32,767	Standard Speed Alarm Position #032
10147	Alarm Position #033 Counter	1	Integer	RO	Y	xx	1.0	0 – 32,767	Standard Speed Alarm Position #033
10148	Alarm Position #034 Counter	1	Integer	RO	Y	xx	1.0	0 – 32,767	Standard Speed Alarm Position #034
10149	Alarm Position #035 Counter	1	Integer	RO	Y	xx	1.0	0 – 32,767	Standard Speed Alarm Position #035
10150	Alarm Position #036 Counter	1	Integer	RO	Y	xx	1.0	0 – 32,767	Standard Speed Alarm Position #036
10151	Alarm Position #037 Counter	1	Integer	RO	Y	xx	1.0	0 – 32,767	Standard Speed Alarm Position #037
10152	Alarm Position #038 Counter	1	Integer	RO	Y	xx	1.0	0 – 32,767	Standard Speed Alarm Position #038

RO = Read only.
R/CW = Read configure writeable if in a setup session.
NV = Nonvolatile.

Table A-5: Registers for Alarms

Reg	Name	Size	Type	Access	NV	Scale	Units	Range	Notes
10153	Alarm Position #039 Counter	1	Integer	RO	Y	xx	1.0	0 – 32,767	Standard Speed Alarm Position #039
10154	Alarm Position #040 Counter	1	Integer	RO	Y	xx	1.0	0 – 32,767	Standard Speed Alarm Position #040
10155	Alarm Position #041 Counter	1	Integer	RO	Y	xx	1.0	0 – 32,767	Standard Speed Alarm Position #041
10156	Alarm Position #042 Counter	1	Integer	RO	Y	xx	1.0	0 – 32,767	Standard Speed Alarm Position #042
10157	Alarm Position #043 Counter	1	Integer	RO	Y	xx	1.0	0 – 32,767	Standard Speed Alarm Position #043
10158	Alarm Position #044 Counter	1	Integer	RO	Y	xx	1.0	0 – 32,767	Standard Speed Alarm Position #044
10159	Alarm Position #045 Counter	1	Integer	RO	Y	xx	1.0	0 – 32,767	Standard Speed Alarm Position #045
10160	Alarm Position #046 Counter	1	Integer	RO	Y	xx	1.0	0 – 32,767	Standard Speed Alarm Position #046
10161	Alarm Position #047 Counter	1	Integer	RO	Y	xx	1.0	0 – 32,767	Standard Speed Alarm Position #047
10162	Alarm Position #048 Counter	1	Integer	RO	Y	xx	1.0	0 – 32,767	Standard Speed Alarm Position #048
10163	Alarm Position #049 Counter	1	Integer	RO	Y	xx	1.0	0 – 32,767	Standard Speed Alarm Position #049
10164	Alarm Position #050 Counter	1	Integer	RO	Y	xx	1.0	0 – 32,767	Standard Speed Alarm Position #050
10165	Alarm Position #051 Counter	1	Integer	RO	Y	xx	1.0	0 – 32,767	Standard Speed Alarm Position #051
10166	Alarm Position #052 Counter	1	Integer	RO	Y	xx	1.0	0 – 32,767	Standard Speed Alarm Position #052
10167	Alarm Position #053 Counter	1	Integer	RO	Y	xx	1.0	0 – 32,767	Standard Speed Alarm Position #053
10168	Alarm Position #054 Counter	1	Integer	RO	Y	xx	1.0	0 – 32,767	Standard Speed Alarm Position #054
10169	Alarm Position #055 Counter	1	Integer	RO	Y	xx	1.0	0 – 32,767	Standard Speed Alarm Position #055
10170	Alarm Position #056 Counter	1	Integer	RO	Y	xx	1.0	0 – 32,767	Standard Speed Alarm Position #056
10171	Alarm Position #057 Counter	1	Integer	RO	Y	xx	1.0	0 – 32,767	Standard Speed Alarm Position #057
10172	Alarm Position #058 Counter	1	Integer	RO	Y	xx	1.0	0 – 32,767	Standard Speed Alarm Position #058
10173	Alarm Position #059 Counter	1	Integer	RO	Y	xx	1.0	0 – 32,767	Standard Speed Alarm Position #059
10174	Alarm Position #060 Counter	1	Integer	RO	Y	xx	1.0	0 – 32,767	Standard Speed Alarm Position #060
10175	Alarm Position #061 Counter	1	Integer	RO	Y	xx	1.0	0 – 32,767	Standard Speed Alarm Position #061
10176	Alarm Position #062 Counter	1	Integer	RO	Y	xx	1.0	0 – 32,767	Standard Speed Alarm Position #062
10177	Alarm Position #063 Counter	1	Integer	RO	Y	xx	1.0	0 – 32,767	Standard Speed Alarm Position #063
10178	Alarm Position #064 Counter	1	Integer	RO	Y	xx	1.0	0 – 32,767	Standard Speed Alarm Position #064
10179	Alarm Position #065 Counter	1	Integer	RO	Y	xx	1.0	0 – 32,767	Standard Speed Alarm Position #065
10180	Alarm Position #066 Counter	1	Integer	RO	Y	xx	1.0	0 – 32,767	Standard Speed Alarm Position #066

RO = Read only.
R/CW = Read configure writeable if in a setup session.
NV = Nonvolatile.

Table A-5:Registers for Alarms

Reg	Name	Size	Type	Access	NV	Scale	Units	Range	Notes
10181	Alarm Position #067 Counter	1	Integer	RO	Y	xx	1.0	0 – 32,767	Standard Speed Alarm Position #067
10182	Alarm Position #068 Counter	1	Integer	RO	Y	xx	1.0	0 – 32,767	Standard Speed Alarm Position #068
10183	Alarm Position #069 Counter	1	Integer	RO	Y	xx	1.0	0 – 32,767	Standard Speed Alarm Position #069
10184	Alarm Position #070 Counter	1	Integer	RO	Y	xx	1.0	0 – 32,767	Standard Speed Alarm Position #070
10185	Alarm Position #071 Counter	1	Integer	RO	Y	xx	1.0	0 – 32,767	Standard Speed Alarm Position #071
10186	Alarm Position #072 Counter	1	Integer	RO	Y	xx	1.0	0 – 32,767	Standard Speed Alarm Position #072
10187	Alarm Position #073 Counter	1	Integer	RO	Y	xx	1.0	0 – 32,767	Standard Speed Alarm Position #073
10188	Alarm Position #074 Counter	1	Integer	RO	Y	xx	1.0	0 – 32,767	Standard Speed Alarm Position #074
10189	Alarm Position #075 Counter	1	Integer	RO	Y	xx	1.0	0 – 32,767	Standard Speed Alarm Position #075
10190	Alarm Position #076 Counter	1	Integer	RO	Y	xx	1.0	0 – 32,767	Standard Speed Alarm Position #076
10191	Alarm Position #077 Counter	1	Integer	RO	Y	xx	1.0	0 – 32,767	Standard Speed Alarm Position #077
10192	Alarm Position #078 Counter	1	Integer	RO	Y	xx	1.0	0 – 32,767	Standard Speed Alarm Position #078
10193	Alarm Position #079 Counter	1	Integer	RO	Y	xx	1.0	0 – 32,767	Standard Speed Alarm Position #079
10194	Alarm Position #080 Counter	1	Integer	RO	Y	xx	1.0	0 – 32,767	Standard Speed Alarm Position #080
10195	Alarm Position #081 Counter	1	Integer	RO	Y	xx	1.0	0 – 32,767	High Speed Alarm Position #001
10196	Alarm Position #082 Counter	1	Integer	RO	Y	xx	1.0	0 – 32,767	High Speed Alarm Position #002
10197	Alarm Position #083 Counter	1	Integer	RO	Y	xx	1.0	0 – 32,767	High Speed Alarm Position #003
10198	Alarm Position #084 Counter	1	Integer	RO	Y	xx	1.0	0 – 32,767	High Speed Alarm Position #004
10199	Alarm Position #085 Counter	1	Integer	RO	Y	xx	1.0	0 – 32,767	High Speed Alarm Position #005
10200	Alarm Position #086 Counter	1	Integer	RO	Y	xx	1.0	0 – 32,767	High Speed Alarm Position #006
10201	Alarm Position #087 Counter	1	Integer	RO	Y	xx	1.0	0 – 32,767	High Speed Alarm Position #007
10202	Alarm Position #088 Counter	1	Integer	RO	Y	xx	1.0	0 – 32,767	High Speed Alarm Position #008
10203	Alarm Position #089 Counter	1	Integer	RO	Y	xx	1.0	0 – 32,767	High Speed Alarm Position #009
10204	Alarm Position #090 Counter	1	Integer	RO	Y	xx	1.0	0 – 32,767	High Speed Alarm Position #010
10205	Alarm Position #091 Counter	1	Integer	RO	Y	xx	1.0	0 – 32,767	High Speed Alarm Position #011
10206	Alarm Position #092 Counter	1	Integer	RO	Y	xx	1.0	0 – 32,767	High Speed Alarm Position #012
10207	Alarm Position #093 Counter	1	Integer	RO	Y	xx	1.0	0 – 32,767	High Speed Alarm Position #013
10208	Alarm Position #094 Counter	1	Integer	RO	Y	xx	1.0	0 – 32,767	High Speed Alarm Position #014

RO = Read only.
R/CW = Read configure writeable if in a setup session.
NV = Nonvolatile.

Table A-5:Registers for Alarms

Reg	Name	Size	Type	Access	NV	Scale	Units	Range	Notes
10209	Alarm Position #095 Counter	1	Integer	RO	Y	xx	1.0	0 – 32,767	High Speed Alarm Position #015
10210	Alarm Position #096 Counter	1	Integer	RO	Y	xx	1.0	0 – 32,767	High Speed Alarm Position #016
10211	Alarm Position #097 Counter	1	Integer	RO	Y	xx	1.0	0 – 32,767	High Speed Alarm Position #017
10212	Alarm Position #098 Counter	1	Integer	RO	Y	xx	1.0	0 – 32,767	High Speed Alarm Position #018
10213	Alarm Position #099 Counter	1	Integer	RO	Y	xx	1.0	0 – 32,767	High Speed Alarm Position #019
10214	Alarm Position #100 Counter	1	Integer	RO	Y	xx	1.0	0 – 32,767	High Speed Alarm Position #020
10215	Alarm Position #101 Counter	1	Integer	RO	Y	xx	1.0	0 – 32,767	Disturbance Alarm Position #001
10216	Alarm Position #102 Counter	1	Integer	RO	Y	xx	1.0	0 – 32,767	Disturbance Alarm Position #002
10217	Alarm Position #103 Counter	1	Integer	RO	Y	xx	1.0	0 – 32,767	Disturbance Alarm Position #003
10218	Alarm Position #104 Counter	1	Integer	RO	Y	xx	1.0	0 – 32,767	Disturbance Alarm Position #004
10219	Alarm Position #105 Counter	1	Integer	RO	Y	xx	1.0	0 – 32,767	Disturbance Alarm Position #005
10220	Alarm Position #106 Counter	1	Integer	RO	Y	xx	1.0	0 – 32,767	Disturbance Alarm Position #006
10221	Alarm Position #107 Counter	1	Integer	RO	Y	xx	1.0	0 – 32,767	Disturbance Alarm Position #007
10222	Alarm Position #108 Counter	1	Integer	RO	Y	xx	1.0	0 – 32,767	Disturbance Alarm Position #008
10223	Alarm Position #109 Counter	1	Integer	RO	Y	xx	1.0	0 – 32,767	Disturbance Alarm Position #009
10224	Alarm Position #110 Counter	1	Integer	RO	Y	xx	1.0	0 – 32,767	Disturbance Alarm Position #010
10225	Alarm Position #111 Counter	1	Integer	RO	Y	xx	1.0	0 – 32,767	Disturbance Alarm Position #011
10226	Alarm Position #112 Counter	1	Integer	RO	Y	xx	1.0	0 – 32,767	Disturbance Alarm Position #012
10227	Alarm Position #113 Counter	1	Integer	RO	Y	xx	1.0	0 – 32,767	Disturbance Alarm Position #013
10228	Alarm Position #114 Counter	1	Integer	RO	Y	xx	1.0	0 – 32,767	Disturbance Alarm Position #014
10229	Alarm Position #115 Counter	1	Integer	RO	Y	xx	1.0	0 – 32,767	Disturbance Alarm Position #015
10230	Alarm Position #116 Counter	1	Integer	RO	Y	xx	1.0	0 – 32,767	Disturbance Alarm Position #016
10231	Alarm Position #117 Counter	1	Integer	RO	Y	xx	1.0	0 – 32,767	Disturbance Alarm Position #017
10232	Alarm Position #118 Counter	1	Integer	RO	Y	xx	1.0	0 – 32,767	Disturbance Alarm Position #018
10233	Alarm Position #119 Counter	1	Integer	RO	Y	xx	1.0	0 – 32,767	Disturbance Alarm Position #019
10234	Alarm Position #120 Counter	1	Integer	RO	Y	xx	1.0	0 – 32,767	Disturbance Alarm Position #020
10235	Alarm Position #121 Counter	1	Integer	RO	Y	xx	1.0	0 – 32,767	Digital Alarm Position #001
10236	Alarm Position #122 Counter	1	Integer	RO	Y	xx	1.0	0 – 32,767	Digital Alarm Position #002

RO = Read only.
R/CW = Read configure writeable if in a setup session.
NV = Nonvolatile.

Table A-5:Registers for Alarms

Reg	Name	Size	Type	Access	NV	Scale	Units	Range	Notes
10237	Alarm Position #123 Counter	1	Integer	RO	Y	xx	1.0	0 – 32,767	Digital Alarm Position #003
10238	Alarm Position #124 Counter	1	Integer	RO	Y	xx	1.0	0 – 32,767	Digital Alarm Position #004
10239	Alarm Position #125 Counter	1	Integer	RO	Y	xx	1.0	0 – 32,767	Digital Alarm Position #005
10240	Alarm Position #126 Counter	1	Integer	RO	Y	xx	1.0	0 – 32,767	Digital Alarm Position #006
10241	Alarm Position #127 Counter	1	Integer	RO	Y	xx	1.0	0 – 32,767	Digital Alarm Position #007
10242	Alarm Position #128 Counter	1	Integer	RO	Y	xx	1.0	0 – 32,767	Digital Alarm Position #008
10243	Alarm Position #129 Counter	1	Integer	RO	Y	xx	1.0	0 – 32,767	Digital Alarm Position #009
10244	Alarm Position #130 Counter	1	Integer	RO	Y	xx	1.0	0 – 32,767	Digital Alarm Position #010
10245	Alarm Position #131 Counter	1	Integer	RO	Y	xx	1.0	0 – 32,767	Digital Alarm Position #011
10246	Alarm Position #132 Counter	1	Integer	RO	Y	xx	1.0	0 – 32,767	Digital Alarm Position #012
10247	Alarm Position #133 Counter	1	Integer	RO	Y	xx	1.0	0 – 32,767	Digital Alarm Position #013
10248	Alarm Position #134 Counter	1	Integer	RO	Y	xx	1.0	0 – 32,767	Digital Alarm Position #014
10249	Alarm Position #135 Counter	1	Integer	RO	Y	xx	1.0	0 – 32,767	Digital Alarm Position #015
10250	Alarm Position #136 Counter	1	Integer	RO	Y	xx	1.0	0 – 32,767	Digital Alarm Position #016
10251	Alarm Position #137 Counter	1	Integer	RO	Y	xx	1.0	0 – 32,767	Digital Alarm Position #017
10252	Alarm Position #138 Counter	1	Integer	RO	Y	xx	1.0	0 – 32,767	Digital Alarm Position #018
10253	Alarm Position #139 Counter	1	Integer	RO	Y	xx	1.0	0 – 32,767	Digital Alarm Position #019
10254	Alarm Position #140 Counter	1	Integer	RO	Y	xx	1.0	0 – 32,767	Digital Alarm Position #020
10255	Alarm Position #141 Counter	1	Integer	RO	Y	xx	1.0	0 – 32,767	Digital Alarm Position #021
10256	Alarm Position #142 Counter	1	Integer	RO	Y	xx	1.0	0 – 32,767	Digital Alarm Position #022
10257	Alarm Position #143 Counter	1	Integer	RO	Y	xx	1.0	0 – 32,767	Digital Alarm Position #023
10258	Alarm Position #144 Counter	1	Integer	RO	Y	xx	1.0	0 – 32,767	Digital Alarm Position #024
10259	Alarm Position #145 Counter	1	Integer	RO	Y	xx	1.0	0 – 32,767	Digital Alarm Position #025
10260	Alarm Position #146 Counter	1	Integer	RO	Y	xx	1.0	0 – 32,767	Digital Alarm Position #026
10261	Alarm Position #147 Counter	1	Integer	RO	Y	xx	1.0	0 – 32,767	Digital Alarm Position #027
10262	Alarm Position #148 Counter	1	Integer	RO	Y	xx	1.0	0 – 32,767	Digital Alarm Position #028
10263	Alarm Position #149 Counter	1	Integer	RO	Y	xx	1.0	0 – 32,767	Digital Alarm Position #029
10264	Alarm Position #150 Counter	1	Integer	RO	Y	xx	1.0	0 – 32,767	Digital Alarm Position #030

RO = Read only.
R/CW = Read configure writeable if in a setup session.
NV = Nonvolatile.

Table A-5:Registers for Alarms

Reg	Name	Size	Type	Access	NV	Scale	Units	Range	Notes
10265	Alarm Position #151 Counter	1	Integer	RO	Y	xx	1.0	0 – 32,767	Digital Alarm Position #031
10266	Alarm Position #152 Counter	1	Integer	RO	Y	xx	1.0	0 – 32,767	Digital Alarm Position #032
10267	Alarm Position #153 Counter	1	Integer	RO	Y	xx	1.0	0 – 32,767	Digital Alarm Position #033
10268	Alarm Position #154 Counter	1	Integer	RO	Y	xx	1.0	0 – 32,767	Digital Alarm Position #034
10269	Alarm Position #155 Counter	1	Integer	RO	Y	xx	1.0	0 – 32,767	Digital Alarm Position #035
10270	Alarm Position #156 Counter	1	Integer	RO	Y	xx	1.0	0 – 32,767	Digital Alarm Position #036
10271	Alarm Position #157 Counter	1	Integer	RO	Y	xx	1.0	0 – 32,767	Digital Alarm Position #037
10272	Alarm Position #158 Counter	1	Integer	RO	Y	xx	1.0	0 – 32,767	Digital Alarm Position #038
10273	Alarm Position #159 Counter	1	Integer	RO	Y	xx	1.0	0 – 32,767	Digital Alarm Position #039
10274	Alarm Position #160 Counter	1	Integer	RO	Y	xx	1.0	0 – 32,767	Digital Alarm Position #040
10275	Alarm Position #161 Counter	1	Integer	RO	Y	xx	1.0	0 – 32,767	Boolean Alarm Position #001
10276	Alarm Position #162 Counter	1	Integer	RO	Y	xx	1.0	0 – 32,767	Boolean Alarm Position #002
10277	Alarm Position #163 Counter	1	Integer	RO	Y	xx	1.0	0 – 32,767	Boolean Alarm Position #003
10278	Alarm Position #164 Counter	1	Integer	RO	Y	xx	1.0	0 – 32,767	Boolean Alarm Position #004
10279	Alarm Position #165 Counter	1	Integer	RO	Y	xx	1.0	0 – 32,767	Boolean Alarm Position #005
10280	Alarm Position #166 Counter	1	Integer	RO	Y	xx	1.0	0 – 32,767	Boolean Alarm Position #006
10281	Alarm Position #167 Counter	1	Integer	RO	Y	xx	1.0	0 – 32,767	Boolean Alarm Position #007
10282	Alarm Position #168 Counter	1	Integer	RO	Y	xx	1.0	0 – 32,767	Boolean Alarm Position #008
10283	Alarm Position #169 Counter	1	Integer	RO	Y	xx	1.0	0 – 32,767	Boolean Alarm Position #009
10284	Alarm Position #170 Counter	1	Integer	RO	Y	xx	1.0	0 – 32,767	Boolean Alarm Position #010
10285	Alarm Position #171 Counter	1	Integer	RO	Y	xx	1.0	0 – 32,767	Boolean Alarm Position #011
10286	Alarm Position #172 Counter	1	Integer	RO	Y	xx	1.0	0 – 32,767	Boolean Alarm Position #012
10287	Alarm Position #173 Counter	1	Integer	RO	Y	xx	1.0	0 – 32,767	Boolean Alarm Position #013
10288	Alarm Position #174 Counter	1	Integer	RO	Y	xx	1.0	0 – 32,767	Boolean Alarm Position #014
10289	Alarm Position #175 Counter	1	Integer	RO	Y	xx	1.0	0 – 32,767	Boolean Alarm Position #015
10290	Alarm Position #176 Counter	1	Integer	RO	Y	xx	1.0	0 – 32,767	Alarm Position #176
10291	Alarm Position #177 Counter	1	Integer	RO	Y	xx	1.0	0 – 32,767	Alarm Position #177
10292	Alarm Position #178 Counter	1	Integer	RO	Y	xx	1.0	0 – 32,767	Alarm Position #178

RO = Read only.
R/CW = Read configure writeable if in a setup session.
NV = Nonvolatile.

Table A-5:Registers for Alarms

Reg	Name	Size	Type	Access	NV	Scale	Units	Range	Notes
10293	Alarm Position #179 Counter	1	Integer	RO	Y	xx	1.0	0 – 32,767	Alarm Position #179
10294	Alarm Position #180 Counter	1	Integer	RO	Y	xx	1.0	0 – 32,767	Alarm Position #180
10295	Alarm Position #181 Counter	1	Integer	RO	Y	xx	1.0	0 – 32,767	Alarm Position #181
10296	Alarm Position #182 Counter	1	Integer	RO	Y	xx	1.0	0 – 32,767	Alarm Position #182
10297	Alarm Position #183 Counter	1	Integer	RO	Y	xx	1.0	0 – 32,767	Alarm Position #183
10298	Alarm Position #184 Counter	1	Integer	RO	Y	xx	1.0	0 – 32,767	Alarm Position #184
10299	Alarm Position #185 Counter	1	Integer	RO	Y	xx	1.0	0 – 32,767	Alarm Position #185

RO = Read only.
R/CW = Read configure writeable if in a setup session.
NV = Nonvolatile.

Table A-6:Spectral Components

Reg	Name	Size	Type	Access	NV	Scale	Units	Range	Notes
28672	Harmonic Magnitudes and Angles, Voltage A-B	128	Integer	RO	N	xx	See Template below	See Template below	See Template below
28800	Harmonic Magnitudes and Angles, Voltage B-C	128	Integer	RO	N	xx	See Template below	See Template below	See Template below
28928	Harmonic Magnitudes and Angles, Voltage C-A	128	Integer	RO	N	xx	See Template below	See Template below	See Template below
29056	Harmonic Magnitudes and Angles, Voltage A-N	128	Integer	RO	N	xx	See Template below	See Template below	See Template below
29184	Harmonic Magnitudes and Angles, Voltage B-N	128	Integer	RO	N	xx	See Template below	See Template below	See Template below
29312	Harmonic Magnitudes and Angles, Voltage C-N	128	Integer	RO	N	xx	See Template below	See Template below	See Template below
29568	Harmonic Magnitudes and Angles, Current, Phase A	128	Integer	RO	N	xx	See Template below	See Template below	See Template below
29696	Harmonic Magnitudes and Angles, Current, Phase B	128	Integer	RO	N	xx	See Template below	See Template below	See Template below
29824	Harmonic Magnitudes and Angles, Current, Phase C	128	Integer	RO	N	xx	See Template below	See Template below	See Template below
29952	Harmonic Magnitudes and Angles, Current, Neutral	128	Integer	RO	N	xx	See Template below	See Template below	See Template below
30080	Harmonic Magnitudes and Angles, Current, Ground	128	Integer	RO	N	xx	See Template below	See Template below	See Template below
30208	Harmonic Magnitudes and Angles, Voltage, Alternate V2-N	128	Integer	RO	N	xx	See Template below	See Template below	See Template below

RO = Read only.
R/CW = Read configure writeable if in a setup session.
NV = Nonvolatile.

Table A-6:Spectral Components

Reg	Name	Size	Type	Access	NV	Scale	Units	Range	Notes
30336	Harmonic Magnitudes and Angles, Current, Alternate I2	128	Integer	RO	N	xx	See Template below	See Template below	See Template below
30464	Harmonic Magnitudes and Angles, Current, Alternate I4	128	Integer	RO	N	xx	See Template below	See Template below	See Template below
30720	Harmonic Sample Data, Voltage A-B	128	Integer	RO	N	xx	Counts	+/- 32,767 (-32,768 if N/A)	Sample data points to describe one power cycle
30848	Harmonic Sample Data, Voltage B-C	128	Integer	RO	N	xx	Counts	+/- 32,767 (-32,768 if N/A)	Sample data points to describe one power cycle
30976	Harmonic Sample Data, Voltage C-A	128	Integer	RO	N	xx	Counts	+/- 32,767 (-32,768 if N/A)	Sample data points to describe one power cycle
31104	Harmonic Sample Data, Voltage A-N	128	Integer	RO	N	xx	Counts	+/- 32,767 (-32,768 if N/A)	Sample data points to describe one power cycle
31232	Harmonic Sample Data, Voltage B-N	128	Integer	RO	N	xx	Counts	+/- 32,767 (-32,768 if N/A)	Sample data points to describe one power cycle
31360	Harmonic Sample Data, Voltage C-N	128	Integer	RO	N	xx	Counts	+/- 32,767 (-32,768 if N/A)	Sample data points to describe one power cycle
31616	Harmonic Sample Data, Current Phase A	128	Integer	RO	N	xx	Counts	+/- 32,767 (-32,768 if N/A)	Sample data points to describe one power cycle
31744	Harmonic Sample Data, Current Phase B	128	Integer	RO	N	xx	Counts	+/- 32,767 (-32,768 if N/A)	Sample data points to describe one power cycle
31872	Harmonic Sample Data, Current Phase C	128	Integer	RO	N	xx	Counts	+/- 32,767 (-32,768 if N/A)	Sample data points to describe one power cycle
32000	Harmonic Sample Data, Current Neutral	128	Integer	RO	N	xx	Counts	+/- 32,767 (-32,768 if N/A)	Sample data points to describe one power cycle
32128	Harmonic Sample Data, Current Ground	128	Integer	RO	N	xx	Counts	+/- 32,767 (-32,768 if N/A)	Sample data points to describe one power cycle
32256	Harmonic Sample Data, Voltage Alternate V2-N	128	Integer	RO	N	xx	Counts	+/- 32,767 (-32,768 if N/A)	Sample data points to describe one power cycle
32384	Harmonic Sample Data, Current Alternate I2	128	Integer	RO	N	xx	Counts	+/- 32,767 (-32,768 if N/A)	Sample data points to describe one power cycle
32512	Harmonic Sample Data, Current Alternate I4	128	Integer	RO	N	xx	Counts	+/- 32,767 (-32,768 if N/A)	Sample data points to describe one power cycle

Template

Base	Reference Magnitude	1	Integer	RO	N	xx	Volts/ Scale Amperes/ Scale	0 – 32,767 (-32,768 if N/A)	Magnitude of fundamental or of overall RMS value upon which harmonic percentages are based. Selection of format based on value in register 3241.
Base +1	Scale Factor	1	Integer	RO	N	xx	1.0	-3 – 3 (-32,768 if N/A)	Power of 10
Base +2	H1 Magnitude	1	Integer	RO	N	xx	0.01%	0 – 32,767 (-32,768 if N/A)	Magnitude of 1st harmonic expressed as a percentage of the reference value
Base +3	H1 Angle	1	Integer	RO	N	xx	0.1 °	0 – 3,599 (-32,678 if N/A)	Angle of 1st harmonic referenced to fundamental Voltage A-N (4-wire) or Voltage A-B (3-wire).
Base +4	H2 Magnitude	1	Integer	RO	N	xx	0.01%	0 – 32,767 (-32,768 if N/A)	Magnitude of 2nd harmonic expressed as a percentage of the reference value
Base +5	H2 Angle	1	Integer	RO	N	xx	0.1 °	0 – 3,599 (-32,678 if N/A)	Angle of 2nd harmonic referenced to fundamental Voltage A-N (4-wire) or Voltage A-B (3-wire).
Base +6	H3 Magnitude	1	Integer	RO	N	xx	0.01%	0 – 32,767 (-32,768 if N/A)	Magnitude of 3rd harmonic expressed as a percentage of the reference value

RO = Read only.
R/CW = Read configure writeable if in a setup session.
NV = Nonvolatile.

Table A-6:Spectral Components

Reg	Name	Size	Type	Access	NV	Scale	Units	Range	Notes
Base +7	H3 Angle	1	Integer	RO	N	xx	0.1 °	0 – 3,599 (-32,678 if N/A)	Angle of 3rd harmonic referenced to fundamental Voltage A-N (4-wire) or Voltage A-B (3-wire).
Base +8	H4 Magnitude	1	Integer	RO	N	xx	0.01%	0 – 32,767 (-32,768 if N/A)	Magnitude of 4th harmonic expressed as a percentage of the reference value
Base +9	H4 Angle	1	Integer	RO	N	xx	0.1 °	0 – 3,599 (-32,678 if N/A)	Angle of 4th harmonic referenced to fundamental Voltage A-N (4-wire) or Voltage A-B (3-wire).
Base +10	H5 Magnitude	1	Integer	RO	N	xx	0.01%	0 – 32,767 (-32,768 if N/A)	Magnitude of 5th harmonic expressed as a percentage of the reference value
Base +11	H5 Angle	1	Integer	RO	N	xx	0.1 °	0 – 3,599 (-32,678 if N/A)	Angle of 5th harmonic referenced to fundamental Voltage A-N (4-wire) or Voltage A-B (3-wire).
Base +12	H6 Magnitude	1	Integer	RO	N	xx	0.01%	0 – 32,767 (-32,768 if N/A)	Magnitude of 6th harmonic expressed as a percentage of the reference value
Base +13	H6 Angle	1	Integer	RO	N	xx	0.1 °	0 – 3,599 (-32,678 if N/A)	Angle of 6th harmonic referenced to fundamental Voltage A-N (4-wire) or Voltage A-B (3-wire).
Base +14	H7 Magnitude	1	Integer	RO	N	xx	0.01%	0 – 32,767 (-32,768 if N/A)	Magnitude of 7th harmonic expressed as a percentage of the reference value
Base +15	H7 Angle	1	Integer	RO	N	xx	0.1 °	0 – 3,599 (-32,678 if N/A)	Angle of 7th harmonic referenced to fundamental Voltage A-N (4-wire) or Voltage A-B (3-wire).
Base +16	H8 Magnitude	1	Integer	RO	N	xx	0.01%	0 – 32,767 (-32,768 if N/A)	Magnitude of 8th harmonic expressed as a percentage of the reference value
Base +17	H8 Angle	1	Integer	RO	N	xx	0.1 °	0 – 3,599 (-32,678 if N/A)	Angle of 8th harmonic referenced to fundamental Voltage A-N (4-wire) or Voltage A-B (3-wire).
Base +18	H9 Magnitude	1	Integer	RO	N	xx	0.01%	0 – 32,767 (-32,768 if N/A)	Magnitude of 9th harmonic expressed as a percentage of the reference value
Base +19	H9 Angle	1	Integer	RO	N	xx	0.1 °	0 – 3,599 (-32,678 if N/A)	Angle of 9th harmonic referenced to fundamental Voltage A-N (4-wire) or Voltage A-B (3-wire).
Base +20	H10 Magnitude	1	Integer	RO	N	xx	0.01%	0 – 32,767 (-32,768 if N/A)	Magnitude of 10th harmonic expressed as a percentage of the reference value
Base +21	H10 Angle	1	Integer	RO	N	xx	0.1 °	0 – 3,599 (-32,678 if N/A)	Angle of 10th harmonic referenced to fundamental Voltage A-N (4-wire) or Voltage A-B (3-wire).
Base +22	H11 Magnitude	1	Integer	RO	N	xx	0.01%	0 – 32,767 (-32,768 if N/A)	Magnitude of 11th harmonic expressed as a percentage of the reference value
Base +23	H11 Angle	1	Integer	RO	N	xx	0.1 °	0 – 3,599 (-32,678 if N/A)	Angle of 11th harmonic referenced to fundamental Voltage A-N (4-wire) or Voltage A-B (3-wire).
Base +24	H12 Magnitude	1	Integer	RO	N	xx	0.01%	0 – 32,767 (-32,768 if N/A)	Magnitude of 12th harmonic expressed as a percentage of the reference value
Base +25	H12 Angle	1	Integer	RO	N	xx	0.1 °	0 – 3,599 (-32,678 if N/A)	Angle of 12th harmonic referenced to fundamental Voltage A-N (4-wire) or Voltage A-B (3-wire).
Base +26	H13 Magnitude	1	Integer	RO	N	xx	0.01%	0 – 32,767 (-32,768 if N/A)	Magnitude of 13th harmonic expressed as a percentage of the reference value

RO = Read only.
R/CW = Read configure writeable if in a setup session.
NV = Nonvolatile.

Table A-6:Spectral Components

Reg	Name	Size	Type	Access	NV	Scale	Units	Range	Notes
Base + 27	H13 Angle	1	Integer	RO	N	xx	0.1 °	0 – 3,599 (-32,678 if N/A)	Angle of 13th harmonic referenced to fundamental Voltage A-N (4-wire) or Voltage A-B (3-wire).
Base + 28	H14 Magnitude	1	Integer	RO	N	xx	0.01%	0 – 32,767 (-32,768 if N/A)	Magnitude of 14th harmonic expressed as a percentage of the reference value
Base + 29	H14 Angle	1	Integer	RO	N	xx	0.1 °	0 – 3,599 (-32,678 if N/A)	Angle of 14th harmonic referenced to fundamental Voltage A-N (4-wire) or Voltage A-B (3-wire).
Base + 30	H15 Magnitude	1	Integer	RO	N	xx	0.01%	0 – 32,767 (-32,768 if N/A)	Magnitude of 15th harmonic expressed as a percentage of the reference value
Base + 31	H15 Angle	1	Integer	RO	N	xx	0.1 °	0 – 3,599 (-32,678 if N/A)	Angle of 15th harmonic referenced to fundamental Voltage A-N (4-wire) or Voltage A-B (3-wire).
Base + 32	H16 Magnitude	1	Integer	RO	N	xx	0.01%	0 – 32,767 (-32,768 if N/A)	Magnitude of 16th harmonic expressed as a percentage of the reference value
Base + 33	H16 Angle	1	Integer	RO	N	xx	0.1 °	0 – 3,599 (-32,678 if N/A)	Angle of 16th harmonic referenced to fundamental Voltage A-N (4-wire) or Voltage A-B (3-wire).
Base + 34	H17 Magnitude	1	Integer	RO	N	xx	0.01%	0 – 32,767 (-32,768 if N/A)	Magnitude of 17th harmonic expressed as a percentage of the reference value
Base + 35	H17 Angle	1	Integer	RO	N	xx	0.1 °	0 – 3,599 (-32,678 if N/A)	Angle of 17th harmonic referenced to fundamental Voltage A-N (4-wire) or Voltage A-B (3-wire).
Base + 36	H18 Magnitude	1	Integer	RO	N	xx	0.01%	0 – 32,767 (-32,768 if N/A)	Magnitude of 18th harmonic expressed as a percentage of the reference value
Base + 37	H18 Angle	1	Integer	RO	N	xx	0.1 °	0 – 3,599 (-32,678 if N/A)	Angle of 18th harmonic referenced to fundamental Voltage A-N (4-wire) or Voltage A-B (3-wire).
Base + 38	H19 Magnitude	1	Integer	RO	N	xx	0.01%	0 – 32,767 (-32,768 if N/A)	Magnitude of 19th harmonic expressed as a percentage of the reference value
Base + 39	H19 Angle	1	Integer	RO	N	xx	0.1 °	0 – 3,599 (-32,678 if N/A)	Angle of 19th harmonic referenced to fundamental Voltage A-N (4-wire) or Voltage A-B (3-wire).
Base + 40	H20 Magnitude	1	Integer	RO	N	xx	0.01%	0 – 32,767 (-32,768 if N/A)	Magnitude of 20th harmonic expressed as a percentage of the reference value
Base + 41	H20 Angle	1	Integer	RO	N	xx	0.1 °	0 – 3,599 (-32,678 if N/A)	Angle of 20th harmonic referenced to fundamental Voltage A-N (4-wire) or Voltage A-B (3-wire).
Base + 42	H21 Magnitude	1	Integer	RO	N	xx	0.01%	0 – 32,767 (-32,768 if N/A)	Magnitude of 21st harmonic expressed as a percentage of the reference value
Base + 43	H21 Angle	1	Integer	RO	N	xx	0.1 °	0 – 3,599 (-32,678 if N/A)	Angle of 21st harmonic referenced to fundamental Voltage A-N (4-wire) or Voltage A-B (3-wire).
Base + 44	H22 Magnitude	1	Integer	RO	N	xx	0.01%	0 – 32,767 (-32,768 if N/A)	Magnitude of 22nd harmonic expressed as a percentage of the reference value
Base + 45	H22 Angle	1	Integer	RO	N	xx	0.1 °	0 – 3,599 (-32,678 if N/A)	Angle of 22nd harmonic referenced to fundamental Voltage A-N (4-wire) or Voltage A-B (3-wire).
Base + 46	H23 Magnitude	1	Integer	RO	N	xx	0.01%	0 – 32,767 (-32,768 if N/A)	Magnitude of 23rd harmonic expressed as a percentage of the reference value

RO = Read only.
R/CW = Read configure writeable if in a setup session.
NV = Nonvolatile.

Table A-6:Spectral Components

Reg	Name	Size	Type	Access	NV	Scale	Units	Range	Notes
Base + 47	H23 Angle	1	Integer	RO	N	xx	0.1 °	0 – 3,599 (-32,678 if N/A)	Angle of 23rd harmonic referenced to fundamental Voltage A-N (4-wire) or Voltage A-B (3-wire).
Base + 48	H24 Magnitude	1	Integer	RO	N	xx	0.01%	0 – 32,767 (-32,768 if N/A)	Magnitude of 24th harmonic expressed as a percentage of the reference value
Base + 49	H24 Angle	1	Integer	RO	N	xx	0.1 °	0 – 3,599 (-32,678 if N/A)	Angle of 24th harmonic referenced to fundamental Voltage A-N (4-wire) or Voltage A-B (3-wire).
Base + 50	H25 Magnitude	1	Integer	RO	N	xx	0.01%	0 – 32,767 (-32,768 if N/A)	Magnitude of 25th harmonic expressed as a percentage of the reference value
Base + 51	H25 Angle	1	Integer	RO	N	xx	0.1 °	0 – 3,599 (-32,678 if N/A)	Angle of 25th harmonic referenced to fundamental Voltage A-N (4-wire) or Voltage A-B (3-wire).
Base + 52	H26 Magnitude	1	Integer	RO	N	xx	0.01%	0 – 32,767 (-32,768 if N/A)	Magnitude of 26th harmonic expressed as a percentage of the reference value
Base + 53	H26 Angle	1	Integer	RO	N	xx	0.1 °	0 – 3,599 (-32,678 if N/A)	Angle of 26th harmonic referenced to fundamental Voltage A-N (4-wire) or Voltage A-B (3-wire).
Base + 54	H27 Magnitude	1	Integer	RO	N	xx	0.01%	0 – 32,767 (-32,768 if N/A)	Magnitude of 27th harmonic expressed as a percentage of the reference value
Base + 55	H27 Angle	1	Integer	RO	N	xx	0.1 °	0 – 3,599 (-32,678 if N/A)	Angle of 27th harmonic referenced to fundamental Voltage A-N (4-wire) or Voltage A-B (3-wire).
Base + 56	H28 Magnitude	1	Integer	RO	N	xx	0.01%	0 – 32,767 (-32,768 if N/A)	Magnitude of 28th harmonic expressed as a percentage of the reference value
Base + 57	H28 Angle	1	Integer	RO	N	xx	0.1 °	0 – 3,599 (-32,678 if N/A)	Angle of 28th harmonic referenced to fundamental Voltage A-N (4-wire) or Voltage A-B (3-wire).
Base + 58	H29 Magnitude	1	Integer	RO	N	xx	0.01%	0 – 32,767 (-32,768 if N/A)	Magnitude of 29th harmonic expressed as a percentage of the reference value
Base + 59	H29 Angle	1	Integer	RO	N	xx	0.1 °	0 – 3,599 (-32,678 if N/A)	Angle of 29th harmonic referenced to fundamental Voltage A-N (4-wire) or Voltage A-B (3-wire).
Base + 60	H30 Magnitude	1	Integer	RO	N	xx	0.01%	0 – 32,767 (-32,768 if N/A)	Magnitude of 30th harmonic expressed as a percentage of the reference value
Base + 61	H30 Angle	1	Integer	RO	N	xx	0.1 °	0 – 3,599 (-32,678 if N/A)	Angle of 30th harmonic referenced to fundamental Voltage A-N (4-wire) or Voltage A-B (3-wire).
Base + 62	H31 Magnitude	1	Integer	RO	N	xx	0.01%	0 – 32,767 (-32,768 if N/A)	Magnitude of 31st harmonic expressed as a percentage of the reference value
Base + 63	H31 Angle	1	Integer	RO	N	xx	0.1 °	0 – 3,599 (-32,678 if N/A)	Angle of 31st harmonic referenced to fundamental Voltage A-N (4-wire) or Voltage A-B (3-wire).
Base + 64	H32 Magnitude	1	Integer	RO	N	xx	0.01%	0 – 32,767 (-32,768 if N/A)	Magnitude of 32nd harmonic expressed as a percentage of the reference value
Base + 65	H32 Angle	1	Integer	RO	N	xx	0.1 °	0 – 3,599 (-32,678 if N/A)	Angle of 32nd harmonic referenced to fundamental Voltage A-N (4-wire) or Voltage A-B (3-wire).
Base + 66	H33 Magnitude	1	Integer	RO	N	xx	0.01%	0 – 32,767 (-32,768 if N/A)	Magnitude of 33rd harmonic expressed as a percentage of the reference value

RO = Read only.
R/CW = Read configure writeable if in a setup session.
NV = Nonvolatile.

Table A-6:Spectral Components

Reg	Name	Size	Type	Access	NV	Scale	Units	Range	Notes
Base + 67	H33 Angle	1	Integer	RO	N	xx	0.1 °	0 – 3,599 (-32,678 if N/A)	Angle of 33rd harmonic referenced to fundamental Voltage A-N (4-wire) or Voltage A-B (3-wire).
Base + 68	H34 Magnitude	1	Integer	RO	N	xx	0.01%	0 – 32,767 (-32,768 if N/A)	Magnitude of 34th harmonic expressed as a percentage of the reference value
Base + 69	H34 Angle	1	Integer	RO	N	xx	0.1 °	0 – 3,599 (-32,678 if N/A)	Angle of 34th harmonic referenced to fundamental Voltage A-N (4-wire) or Voltage A-B (3-wire).
Base + 70	H35 Magnitude	1	Integer	RO	N	xx	0.01%	0 – 32,767 (-32,768 if N/A)	Magnitude of 35th harmonic expressed as a percentage of the reference value
Base + 71	H35 Angle	1	Integer	RO	N	xx	0.1 °	0 – 3,599 (-32,678 if N/A)	Angle of 35th harmonic referenced to fundamental Voltage A-N (4-wire) or Voltage A-B (3-wire).
Base + 72	H36 Magnitude	1	Integer	RO	N	xx	0.01%	0 – 32,767 (-32,768 if N/A)	Magnitude of 36th harmonic expressed as a percentage of the reference value
Base + 73	H36 Angle	1	Integer	RO	N	xx	0.1 °	0 – 3,599 (-32,678 if N/A)	Angle of 36th harmonic referenced to fundamental Voltage A-N (4-wire) or Voltage A-B (3-wire).
Base + 74	H37 Magnitude	1	Integer	RO	N	xx	0.01%	0 – 32,767 (-32,768 if N/A)	Magnitude of 37th harmonic expressed as a percentage of the reference value
Base + 75	H37 Angle	1	Integer	RO	N	xx	0.1 °	0 – 3,599 (-32,678 if N/A)	Angle of 37th harmonic referenced to fundamental Voltage A-N (4-wire) or Voltage A-B (3-wire).
Base + 76	H38 Magnitude	1	Integer	RO	N	xx	0.01%	0 – 32,767 (-32,768 if N/A)	Magnitude of 38th harmonic expressed as a percentage of the reference value
Base + 77	H38 Angle	1	Integer	RO	N	xx	0.1 °	0 – 3,599 (-32,678 if N/A)	Angle of 38th harmonic referenced to fundamental Voltage A-N (4-wire) or Voltage A-B (3-wire).
Base + 78	H39 Magnitude	1	Integer	RO	N	xx	0.01%	0 – 32,767 (-32,768 if N/A)	Magnitude of 39th harmonic expressed as a percentage of the reference value
Base + 79	H39 Angle	1	Integer	RO	N	xx	0.1 °	0 – 3,599 (-32,678 if N/A)	Angle of 39th harmonic referenced to fundamental Voltage A-N (4-wire) or Voltage A-B (3-wire).
Base + 80	H40 Magnitude	1	Integer	RO	N	xx	0.01%	0 – 32,767 (-32,768 if N/A)	Magnitude of 40th harmonic expressed as a percentage of the reference value
Base + 81	H40 Angle	1	Integer	RO	N	xx	0.1 °	0 – 3,599 (-32,678 if N/A)	Angle of 40th harmonic referenced to fundamental Voltage A-N (4-wire) or Voltage A-B (3-wire).
Base + 82	H41 Magnitude	1	Integer	RO	N	xx	0.01%	0 – 32,767 (-32,768 if N/A)	Magnitude of 41st harmonic expressed as a percentage of the reference value
Base + 83	H41 Angle	1	Integer	RO	N	xx	0.1 °	0 – 3,599 (-32,678 if N/A)	Angle of 41st harmonic referenced to fundamental Voltage A-N (4-wire) or Voltage A-B (3-wire).
Base + 84	H42 Magnitude	1	Integer	RO	N	xx	0.01%	0 – 32,767 (-32,768 if N/A)	Magnitude of 42nd harmonic expressed as a percentage of the reference value
Base + 85	H42 Angle	1	Integer	RO	N	xx	0.1 °	0 – 3,599 (-32,678 if N/A)	Angle of 42nd harmonic referenced to fundamental Voltage A-N (4-wire) or Voltage A-B (3-wire).
Base + 86	H43 Magnitude	1	Integer	RO	N	xx	0.01%	0 – 32,767 (-32,768 if N/A)	Magnitude of 43rd harmonic expressed as a percentage of the reference value

RO = Read only.
R/CW = Read configure writeable if in a setup session.
NV = Nonvolatile.

Table A-6:Spectral Components

Reg	Name	Size	Type	Access	NV	Scale	Units	Range	Notes
Base + 87	H43 Angle	1	Integer	RO	N	xx	0.1 °	0 – 3,599 (-32,678 if N/A)	Angle of 43rd harmonic referenced to fundamental Voltage A-N (4-wire) or Voltage A-B (3-wire).
Base + 88	H44 Magnitude	1	Integer	RO	N	xx	0.01%	0 – 32,767 (-32,768 if N/A)	Magnitude of 44th harmonic expressed as a percentage of the reference value
Base + 89	H44 Angle	1	Integer	RO	N	xx	0.1 °	0 – 3,599 (-32,678 if N/A)	Angle of 44th harmonic referenced to fundamental Voltage A-N (4-wire) or Voltage A-B (3-wire).
Base + 90	H45 Magnitude	1	Integer	RO	N	xx	0.01%	0 – 32,767 (-32,768 if N/A)	Magnitude of 45th harmonic expressed as a percentage of the reference value
Base + 91	H45 Angle	1	Integer	RO	N	xx	0.1 °	0 – 3,599 (-32,678 if N/A)	Angle of 45th harmonic referenced to fundamental Voltage A-N (4-wire) or Voltage A-B (3-wire).
Base + 92	H46 Magnitude	1	Integer	RO	N	xx	0.01%	0 – 32,767 (-32,768 if N/A)	Magnitude of 46th harmonic expressed as a percentage of the reference value
Base + 93	H46 Angle	1	Integer	RO	N	xx	0.1 °	0 – 3,599 (-32,678 if N/A)	Angle of 46th harmonic referenced to fundamental Voltage A-N (4-wire) or Voltage A-B (3-wire).
Base + 94	H47 Magnitude	1	Integer	RO	N	xx	0.01%	0 – 32,767 (-32,768 if N/A)	Magnitude of 47th harmonic expressed as a percentage of the reference value
Base + 95	H47 Angle	1	Integer	RO	N	xx	0.1 °	0 – 3,599 (-32,678 if N/A)	Angle of 47th harmonic referenced to fundamental Voltage A-N (4-wire) or Voltage A-B (3-wire).
Base + 96	H48 Magnitude	1	Integer	RO	N	xx	0.01%	0 – 32,767 (-32,768 if N/A)	Magnitude of 48th harmonic expressed as a percentage of the reference value
Base + 97	H48 Angle	1	Integer	RO	N	xx	0.1 °	0 – 3,599 (-32,678 if N/A)	Angle of 48th harmonic referenced to fundamental Voltage A-N (4-wire) or Voltage A-B (3-wire).
Base + 98	H49 Magnitude	1	Integer	RO	N	xx	0.01%	0 – 32,767 (-32,768 if N/A)	Magnitude of 49th harmonic expressed as a percentage of the reference value
Base + 99	H49 Angle	1	Integer	RO	N	xx	0.1 °	0 – 3,599 (-32,678 if N/A)	Angle of 49th harmonic referenced to fundamental Voltage A-N (4-wire) or Voltage A-B (3-wire).
Base + 100	H50 Magnitude	1	Integer	RO	N	xx	0.01%	0 – 32,767 (-32,768 if N/A)	Magnitude of 50th harmonic expressed as a percentage of the reference value
Base + 101	H50 Angle	1	Integer	RO	N	xx	0.1 °	0 – 3,599 (-32,678 if N/A)	Angle of 50th harmonic referenced to fundamental Voltage A-N (4-wire) or Voltage A-B (3-wire).
Base + 102	H51 Magnitude	1	Integer	RO	N	xx	0.01%	0 – 32,767 (-32,768 if N/A)	Magnitude of 51st harmonic expressed as a percentage of the reference value
Base + 103	H51 Angle	1	Integer	RO	N	xx	0.1 °	0 – 3,599 (-32,678 if N/A)	Angle of 51st harmonic referenced to fundamental Voltage A-N (4-wire) or Voltage A-B (3-wire).
Base + 104	H52 Magnitude	1	Integer	RO	N	xx	0.01%	0 – 32,767 (-32,768 if N/A)	Magnitude of 52nd harmonic expressed as a percentage of the reference value
Base + 105	H52 Angle	1	Integer	RO	N	xx	0.1 °	0 – 3,599 (-32,678 if N/A)	Angle of 52nd harmonic referenced to fundamental Voltage A-N (4-wire) or Voltage A-B (3-wire).
Base + 106	H53 Magnitude	1	Integer	RO	N	xx	0.01%	0 – 32,767 (-32,768 if N/A)	Magnitude of 53rd harmonic expressed as a percentage of the reference value

RO = Read only.
R/CW = Read configure writeable if in a setup session.
NV = Nonvolatile.

Table A-6:Spectral Components

Reg	Name	Size	Type	Access	NV	Scale	Units	Range	Notes
Base + 107	H53 Angle	1	Integer	RO	N	xx	0.1 °	0 – 3,599 (-32,678 if N/A)	Angle of 53rd harmonic referenced to fundamental Voltage A-N (4-wire) or Voltage A-B (3-wire).
Base + 108	H54 Magnitude	1	Integer	RO	N	xx	0.01%	0 – 32,767 (-32,768 if N/A)	Magnitude of 54th harmonic expressed as a percentage of the reference value
Base + 109	H54 Angle	1	Integer	RO	N	xx	0.1 °	0 – 3,599 (-32,678 if N/A)	Angle of 54th harmonic referenced to fundamental Voltage A-N (4-wire) or Voltage A-B (3-wire).
Base + 110	H55 Magnitude	1	Integer	RO	N	xx	0.01%	0 – 32,767 (-32,768 if N/A)	Magnitude of 55th harmonic expressed as a percentage of the reference value
Base + 111	H55 Angle	1	Integer	RO	N	xx	0.1 °	0 – 3,599 (-32,678 if N/A)	Angle of 55th harmonic referenced to fundamental Voltage A-N (4-wire) or Voltage A-B (3-wire).
Base + 112	H56 Magnitude	1	Integer	RO	N	xx	0.01%	0 – 32,767 (-32,768 if N/A)	Magnitude of 56th harmonic expressed as a percentage of the reference value
Base + 113	H56 Angle	1	Integer	RO	N	xx	0.1 °	0 – 3,599 (-32,678 if N/A)	Angle of 56th harmonic referenced to fundamental Voltage A-N (4-wire) or Voltage A-B (3-wire).
Base + 114	H57 Magnitude	1	Integer	RO	N	xx	0.01%	0 – 32,767 (-32,768 if N/A)	Magnitude of 57th harmonic expressed as a percentage of the reference value
Base + 115	H57 Angle	1	Integer	RO	N	xx	0.1 °	0 – 3,599 (-32,678 if N/A)	Angle of 57th harmonic referenced to fundamental Voltage A-N (4-wire) or Voltage A-B (3-wire).
Base + 116	H58 Magnitude	1	Integer	RO	N	xx	0.01%	0 – 32,767 (-32,768 if N/A)	Magnitude of 58th harmonic expressed as a percentage of the reference value
Base + 117	H58 Angle	1	Integer	RO	N	xx	0.1 °	0 – 3,599 (-32,678 if N/A)	Angle of 58th harmonic referenced to fundamental Voltage A-N (4-wire) or Voltage A-B (3-wire).
Base + 118	H59 Magnitude	1	Integer	RO	N	xx	0.01%	0 – 32,767 (-32,768 if N/A)	Magnitude of 59th harmonic expressed as a percentage of the reference value
Base + 119	H59 Angle	1	Integer	RO	N	xx	0.1 °	0 – 3,599 (-32,678 if N/A)	Angle of 59th harmonic referenced to fundamental Voltage A-N (4-wire) or Voltage A-B (3-wire).
Base + 120	H60 Magnitude	1	Integer	RO	N	xx	0.01%	0 – 32,767 (-32,768 if N/A)	Magnitude of 60th harmonic expressed as a percentage of the reference value
Base + 121	H60 Angle	1	Integer	RO	N	xx	0.1 °	0 – 3,599 (-32,678 if N/A)	Angle of 60th harmonic referenced to fundamental Voltage A-N (4-wire) or Voltage A-B (3-wire).
Base + 122	H61 Magnitude	1	Integer	RO	N	xx	0.01%	0 – 32,767 (-32,768 if N/A)	Magnitude of 61st harmonic expressed as a percentage of the reference value
Base + 123	H61 Angle	1	Integer	RO	N	xx	0.1 °	0 – 3,599 (-32,678 if N/A)	Angle of 61st harmonic referenced to fundamental Voltage A-N (4-wire) or Voltage A-B (3-wire).
Base + 124	H62 Magnitude	1	Integer	RO	N	xx	0.01%	0 – 32,767 (-32,768 if N/A)	Magnitude of 62nd harmonic expressed as a percentage of the reference value
Base + 125	H62 Angle	1	Integer	RO	N	xx	0.1 °	0 – 3,599 (-32,678 if N/A)	Angle of 62nd harmonic referenced to fundamental Voltage A-N (4-wire) or Voltage A-B (3-wire).
Base + 126	H63 Magnitude	1	Integer	RO	N	xx	0.01%	0 – 32,767 (-32,768 if N/A)	Magnitude of 63rd harmonic expressed as a percentage of the reference value

RO = Read only.
R/CW = Read configure writeable if in a setup session.
NV = Nonvolatile.

Table A-6:Spectral Components

Reg	Name	Size	Type	Access	NV	Scale	Units	Range	Notes
Base + 127	H63 Angle	1	Integer	RO	N	xx	0.1 °	0 – 3,599 (-32,678 if N/A)	Angle of 63rd harmonic referenced to fundamental Voltage A-N (4-wire) or Voltage A-B (3-wire).

RO = Read only.
R/CW = Read configure writeable if in a setup session.
NV = Nonvolatile.

APPENDIX B—USING THE COMMAND INTERFACE

This appendix describes how to use the command interface to perform various operations.

CONTENTS

CONTENTS	199
OVERVIEW OF THE COMMAND INTERFACE	200
Issuing Commands	201
I/O POINT NUMBERS	204
OPERATING OUTPUTS FROM THE COMMAND INTERFACE	205
USING THE COMMAND INTERFACE TO CHANGE CONFIGURATION REGISTERS	205
CONDITIONAL ENERGY	206
Command Interface Control	206
Digital Input Control	206
INCREMENTAL ENERGY	207
Using Incremental Energy	207
SETTING UP INDIVIDUAL HARMONIC CALCULATIONS	208
CHANGING SCALE FACTORS	209

OVERVIEW OF THE COMMAND INTERFACE

The circuit monitor provides a command interface, which you can use to issue commands that perform various operations such as controlling relays. Table B– 2 on page 201 lists the available commands. The command interface is located in memory at registers 8000–8149. Table B– 1 lists the definitions for the registers.

Table B– 1: Location of the command interface

Register	Description
8000	This is the register where you write the commands.
8001–8015	These are the registers where you write the parameters for a command. Commands can have up to 15 parameters associated with them.
8017	Status pointer to the user area. The status of the last command processed is placed in this register.
8018	Results pointer to the user area. When an error occurs, the error code is placed in this register.
8019	I/O data pointer to the user area. Use this register to point to data buffer registers where you can send additional data or return data.
8020–8149	These registers are for you (the user) to write information. Depending on which pointer places the information in the register, the register can contain status (from pointer 8017), results (from pointer 8018), or data (from pointer 8019). The registers will contain information such as whether the function is enabled or disabled, set to fill and hold, start and stop times, logging intervals, and so forth. By default, return data will start at 8020 unless you specify otherwise.

When registers 8017–8019 are set to zero, no values are returned. When any or all of these registers contain a value, the value in the register “points” to a target register, which contains the status, error code, or I/O data (depending on the command) when the command is executed. Figure B–1 shows how these registers work.

NOTE: You determine the register location where results will be written. Therefore, take care when assigning register values in the pointer registers; values may be corrupted when two commands use the same register.

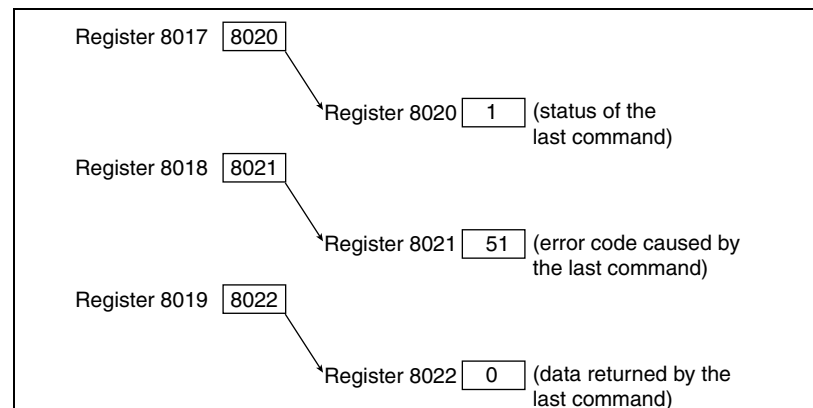

Figure B–1: Command Interface Pointer Registers

Issuing Commands

To issue commands using the command interface, follow these general steps:

1. Write the related parameter(s) to the command parameter registers 8001–15.
2. Write the command code to command interface register 8000.

If no parameters are associated with the command, then you need only to write the command code to register 8000. Table B– 2 lists the command codes that can be written to the command interface into register 8000. Some commands have an associated registers where you write parameters for that command. For example, when you write the parameter 9999 to register 8001 and issue command code 3351, all relays will be energized if they are set up for external control.

Table B– 2: Command Codes

Command Code	Command Parameter Register	Parameters	Description
1110	None	None	Causes soft reset of the unit (re-initializes the circuit monitor).
1210	None	None	Clears the communications counters.
1310	8001 8002 8003 8004 8005 8006	Month Day Year Hour Minute Second	Sets the system date and time. Values for the registers are: Month (1–12) Day (1–31) Year (4-digit, for example 2000) Hour (Military time, for example 14 = 2:00pm) Minute (1–59) Second (1–59)
1410	None	None	Disables the revenue security switch.
1411	None	None	Enables the revenue security switch.

Relay Outputs

3310	8001	Relay Output Number ①	Configures relay for external control.
3311	8001	Relay Output Number ①	Configures relay for internal control.
3320	8001	Relay Output Number ①	De-energizes designated relay.
3321	8001	Relay Output Number ①	Energizes designated relay.
3330	8001	Relay Output Number ①	Releases specified relay from latched condition.
3340	8001	Relay Output Number ①	Releases specified relay from override control.
3341	8001	Relay Output Number ①	Places specified relay under override control.
3350	8001	9999	De-energizes all relays.
3351	8001	9999	Energizes all relays.
3361	8001	Relay Output Number ①	Resets operation counter for specified relay.
3362	8001	Relay Output Number ①	Resets the turn-on time for specified relay.
3363	8001	None	Resets the operation counter for all relays.
3364	8001	None	Resets the turn-on time for all relays.
3365	8001	Input Number ①	Resets the operation counter for specified input.
3366	8001	Input Number ①	Resets turn-on time for specified input.
3367	8001	None	Resets the operation counter for all inputs.

- ① You must write to register 8001 the number that identifies which output you would like to use. To determine the identifying number, refer to “I/O Point NumberS” on page 204 for instructions.
- ② Data buffer location (register 8019) is the pointer to the first register where data will be stored. By default, return data begins at register 8020, although you can use any of the registers from 8020–8149. *Take care when assigning pointers. Values may be corrupted if two commands are using the same register.*

Table B– 2: Command Codes

Command Code	Command Parameter Register	Parameters	Description
3368	8001	None	Resets turn-on time for all inputs.
3369	8001	None	Resets all counters and timers for all I/Os.
3370	8001	Analog Output Number ①	Disables specified analog output.
3371	8001	Analog Output Number ①	Enables specified analog output.
3380	8001	9999	Disables all analog outputs.
3381	8002	9999	Enables all analog outputs.
Resets			
4110	None	None	Resets min/max.
4210	8001	1 = Voltage 2 = Current 3 = Both	Resets the register-based alarm logs.
5110	None	None	Resets all demand registers.
5111	None	None	Resets current demand.
5112	None	None	Resets voltage demand.
5113	None	None	Resets power demand.
5114	None	None	Resets input demand.
5115	None	None	Resets generic 1 demand for first group of 10 quantities.
5116	None	None	Resets generic 2 demand for second group of 10 quantities.
5210	None	None	Resets all min/max demand.
5211	None	None	Resets current min/max demand.
5212	None	None	Resets voltage min/max demand.
5213	None	None	Resets power min/max demand.
5214	None	None	Resets input min/max demand.
5215	None	None	Resets generic 1 min/max demand.
5216	None	None	Resets generic 2 min/max demand.
5910	8001	Bitmap	Start new demand interval. Bit0 = Power Demand 1 = Current Demand 2 = Voltage Demand 3 = Input Metering Demand 4 = Generic Demand Profile 1 5 = Generic Demand Profile 2

- ① You must write to register 8001 the number that identifies which output you would like to use. To determine the identifying number, refer to “I/O Point NumberS” on page 204 for instructions.
- ② Data buffer location (register 8019) is the pointer to the first register where data will be stored. By default, return data begins at register 8020, although you can use any of the registers from 8020–8149. *Take care when assigning pointers. Values may be corrupted if two commands are using the same register.*

Table B– 2: Command Codes

Command Code	Command Parameter Register	Parameters	Description
6209	8019	I/O Data Pointer ②	Preset Accumulated Energies Requires the IO Data Pointer to point to registers where energy preset values are entered. All Accumulated energy values must be entered in the order in which they occur in registers 1700 to 1727.
6210	None	None	Clears all energies.
6211	None	None	Clears all accumulated energy values.
6212	None	None	Clears conditional energy values.
6213	None	None	Clears incremental energy values.
6214	None	None	Clears input metering accumulation.
6320	None	None	Disables conditional energy accumulation.
6321	None	None	Enables conditional energy accumulation.
6910	None	None	Starts a new incremental energy interval.
Files			
7510	8001	Files 1–16 to trigger	Triggers data log entry. Bitmap where Bit 0 = Data Log 1, Bit 1 = Data Log 2, Bit 2 = Data Log 3, etc.
7511	8001	File Number	Triggers single data log entry.
Setup			
9020	None	None	Enter into setup mode.
9021	8001	1 = Save 2 = Do not save	Exit setup mode and save all changes.

- ① You must write to register 8001 the number that identifies which output you would like to use. To determine the identifying number, refer to “I/O Point NumbeRS” on page 204 for instructions.
- ② Data buffer location (register 8019) is the pointer to the first register where data will be stored. By default, return data begins at register 8020, although you can use any of the registers from 8020–8149. *Take care when assigning pointers. Values may be corrupted if two commands are using the same register.*

I/O POINT NUMBERS

All inputs and outputs of the circuit monitor have a reference number and a label that correspond to the position of that particular input or output.

- The reference number is used to manually control the input or output with the command interface.
- The label is the default identifier that identifies that same input or output. The label appears on the display, in SMS, and on the option card.

Figure B-2 shows the reference number and its label equivalent.

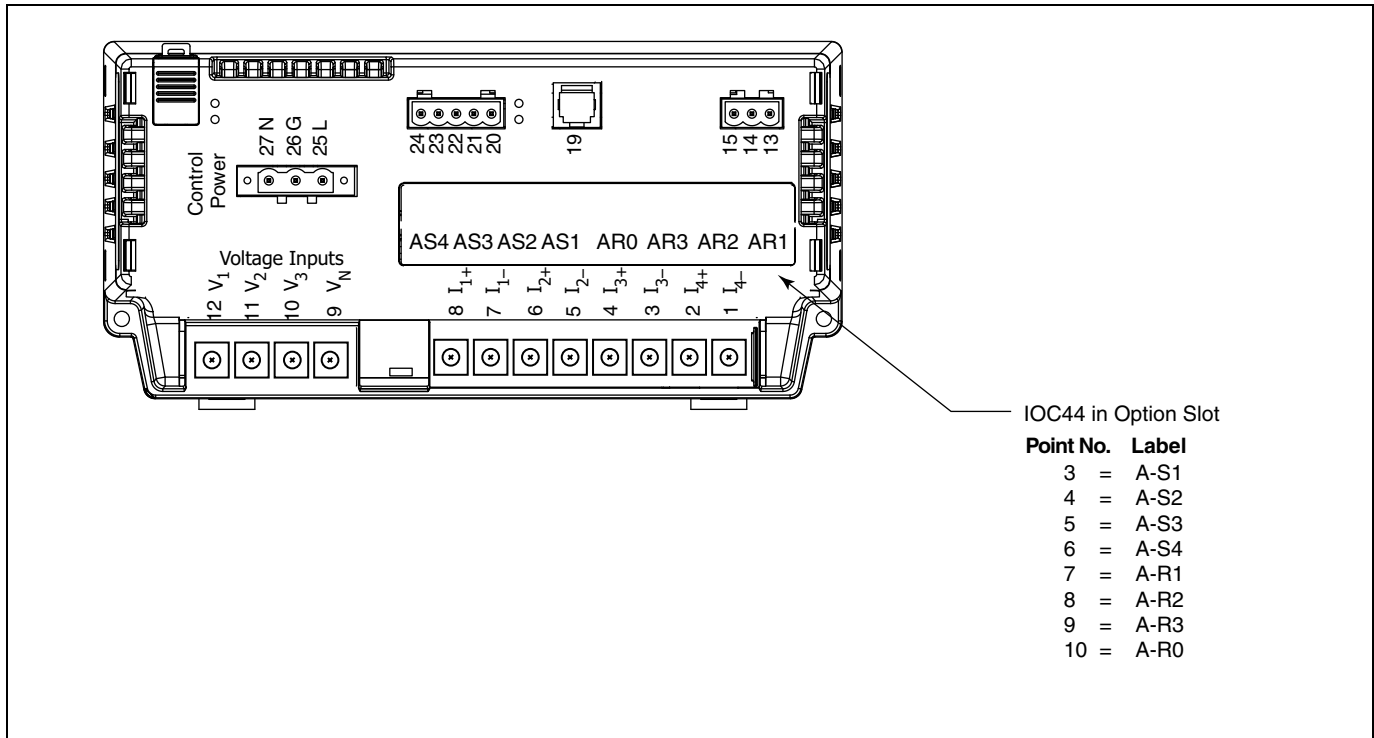

Figure B-2: Identifying I/Os for the command interface

OPERATING OUTPUTS FROM THE COMMAND INTERFACE

To operate an output from the command interface, first identify the relay using the *I/O point number*. Then, set the output to external control. For example, to energize the last output on Option Card B, write the commands as follows:

1. Write number 26 to register 8001.
2. Write command code 3310 to register 8000 to set the relay to external control.
3. Write command code 3321 to register 8000.

If you look in Table B– 2 on page 201, you'll see that command code 3310 sets the relay to external control and command code 3321 is listed as the command used to energize a relay. Command codes 3310–3381 are for use with inputs and outputs.

USING THE COMMAND INTERFACE TO CHANGE CONFIGURATION REGISTERS

You can also use the command interface to change values in selected metering-related registers, such as synchronizing the time of day of the clock or resetting generic demand.

Two commands, 9020 and 9021, work together as part of the command interface procedure when you use it to change circuit monitor configuration. You must first issue command 9020 to enter into setup mode, change the register, and then issue 9021 to save your changes and exit setup mode.

Only one setup session is allowed at a time. While in this mode, if the circuit monitor detects more than two minutes of inactivity, that is, if you do not write any register values or press any buttons on the display, the circuit monitor will timeout and restore the original configuration values. All changes will be lost. Also, if the circuit monitor loses power or communications while in setup mode, your changes will be lost.

The general procedure for changing configuration registers using the command interface is as follows:

1. Issue command 9020 in register 8000 to enter into the setup mode.
2. Make changes to the appropriate register by writing the new value to that register. Perform register writes to all registers that you want to change. For instructions on reading and writing registers, see "Reading and Writing Registers" on page 43 in **Chapter 3—Operation**.
3. To save the changes, write the value 1 to register 8001.
NOTE: Writing any other value except 1 to register 8001 lets you exit setup mode without saving your changes.
4. Issue command 9021 in register 8000 to initiate the save and reset the circuit monitor.

For example, the procedure to change the demand interval for current is as follows:

1. Issue command code 9020.
2. Write the new demand interval to register 1801.
3. Write 1 to register 8001.
4. Issue command code 9021.

See **Appendix A—Abbreviated Register Listing** on page 121 for those registers that require you to enter setup mode to make changes to the registers.

CONDITIONAL ENERGY

Circuit monitor registers 1728–1744 are conditional energy registers.

Conditional energy can be controlled in one of two ways:

- Over the communications link, by writing commands to the circuit monitor's command interface, or
- By a digital input—for example, conditional energy accumulates when the assigned digital input is on, but does not accumulate when the digital input is off.

The following procedures tell how to set up conditional energy for command interface control, and for digital input control. The procedures refer to register numbers and command codes. For a listing of circuit monitor registers, see **Appendix A—Abbreviated Register Listing** on page 121. For a listing of command codes, see Table B– 2 on page 201 in this chapter.

Command Interface Control

Set Control—To *set control* of conditional energy to the command interface:

1. Write command code 9020 to register 8000.
2. In register 3227, set bit 6 to 1 (preserve other bits that are ON).
3. Write 1 to register 8001.
4. Write command code 9021 to register 8000.

Start— To *start* conditional energy accumulation, write command code 6321 to register 8000.

Verify Setup—To *verify proper setup*, read register 1794. The register should read 1, indicating conditional energy accumulation is ON.

Stop—To *stop* conditional energy accumulation, write command code 6320 to register 8000.

Clear—To *clear* all conditional energy registers (1728-1747), write command code 6212 to register 8000.

Digital Input Control

Set Control—To configure conditional energy for digital input control:

1. Write command code 9020 to register 8000.
2. In register 3227, set bit 6 to 0 (preserve other bits that are ON).
3. Configure the digital input that will drive conditional energy accumulation. For the appropriate digital input, write 3 to the *Base +9* register. See the digital input templates in Table A–4 on page 176 in **Appendix A—Abbreviated Register Listing**.
4. Write 1 to register 8001.
5. Write command code 9021 to register 8000.

Clear—To clear all conditional energy registers (1728–1747), write command code 6212 to register 8000.

Verify Setup—To *verify proper setup*, read register 1794. The register should read 0 when the digital input is off, indicating that conditional energy accumulation is off. The register should read 1 when conditional energy accumulation is on.

INCREMENTAL ENERGY

The circuit monitor's incremental energy feature allows you to define a start time, end time, and time interval for incremental energy accumulation. At the end of each incremental energy period, the following information is available:

- Wh IN during the last completed interval (reg. 1748–1750)
- VARh IN during the last completed interval (reg. 1751–1753)
- Wh OUT during the last completed interval (reg. 1754–1756)
- VARh OUT during the last completed interval (reg. 1757–1759)
- VAh during the last completed interval (reg. 1760–1762)
- Date/time of the last completed interval (reg. 1763–1766)
- Peak kW demand during the last completed interval (reg. 1940)
- Date/Time of Peak kW during the last interval (reg. 1941–1944)
- Peak kVAR demand during the last completed interval (reg. 1945)
- Date/Time of Peak kVAR during the last interval (reg. 1946–1949)
- Peak kVA demand during the last completed interval (reg. 1950)
- Date/Time of Peak kVA during the last interval (reg. 1951–1954)

The circuit monitor can log the incremental energy data listed above. This logged data provides all the information needed to analyze energy and power usage against present or future utility rates. The information is especially useful for comparing different time-of-use rate structures.

When using the incremental energy feature, keep the following points in mind:

- Peak demands help minimize the size of the data log in cases of sliding or rolling demand. Shorter incremental energy periods make it easier to reconstruct a load profile analysis.
- Since the incremental energy registers are synchronized to the circuit monitor clock, it is possible to log this data from multiple circuits and perform accurate totalizing.

Using Incremental Energy

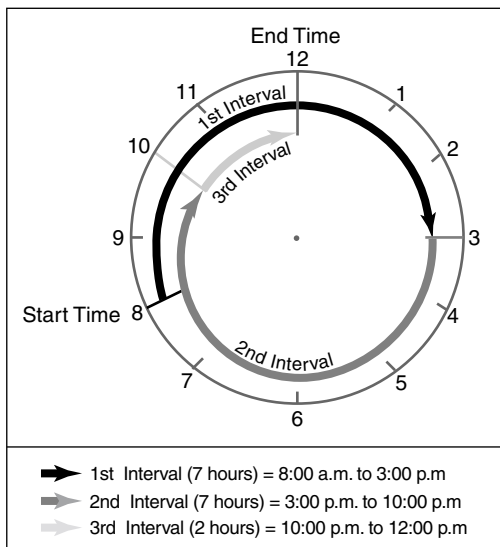

Figure B-3: Incremental Energy Example

Incremental energy accumulation begins at the specified start time and ends at the specified end time. When the start time arrives, a new incremental energy period begins. The start and end time are specified in minutes from midnight. For example:

Interval: 420 minutes (7 hours)
Start time: 480 minutes (8:00 a.m.)
End time = 1440 minutes (12:00 p.m.)

The first incremental energy calculation will be from 8:00 a.m. to 3:00 p.m. (7 hours) as illustrated in Figure B-3. The next interval will be from 3:00 p.m. to 10:00 p.m., and the third interval will be from 10 p.m. to 12:00 p.m. because 12:00 p.m. is the specified end time. A new interval will begin on the next day at 8:00 a.m. Incremental energy accumulation will continue in this manner until the configuration is changed or a new interval is started by a remote master.

Set up—To set up incremental energy:

1. Write command code 9020 to register 8000.
2. In register 3230, write a start time (in minutes-from-midnight).
For example, 8:00 am is 480 minutes.
3. In register 3231, write an end time (in minutes-from-midnight).
4. Write the desired interval length, from 0–1440 minutes, to register 3229.
If incremental energy will be controlled from a remote master, such as a programmable controller, write 0 to the register.
5. Write 1 to register 8001.
6. Write command code 9021 to register 8000.

Start—To start a new incremental energy interval from a remote master, write command code 6910 to register 8000.

SETTING UP INDIVIDUAL HARMONIC CALCULATIONS

The circuit monitor can perform harmonic magnitude and angle calculations for each metered value and for each residual value. The harmonic magnitude can be formatted as either a percentage of the fundamental (THD) or as a percentage of the rms values (thd). The harmonic magnitude and angles are stored in a set of registers: 28,672–30,719. During the time that the circuit monitor is refreshing harmonic data, the circuit monitor posts a value of 0 in register 3245. When the set of harmonic registers is updated with new data, the circuit monitor posts a value of 1 in register 3245. The circuit monitor can be configured to hold the values in these registers for up to 60 metering update cycles once the data processing is complete.

The circuit monitor has three operating modes for harmonic data processing: disabled, magnitude only, and magnitude and angles. Because of the extra processing time necessary to perform these calculations, the factory default operating mode is magnitudes only.

To configure the harmonic data processing, write to the registers described in Table B– 3:

Table B– 3: Registers for Harmonic Calculations

Reg No.	Value	Description
3240	0, 1, 2	Harmonic processing; 0 = disabled 1 = magnitudes only enabled 2 = magnitudes and angles enabled
3241	0, 1	Harmonic magnitude formatting; 0 = % of fundamental (default) 1 = % of rms
3242	10–60 seconds	Harmonics Refresh Interval Default = 30 seconds
3243	10–60 seconds	This register shows the time remaining before the next update (of harmonic data).
3245	0,1	This register indicates whether harmonic data processing is complete: 0 = processing incomplete 1 = processing complete

CHANGING SCALE FACTORS

The circuit monitor stores instantaneous metering data in 16-bit single registers. A value held in each register must be an integer between -32,767 and +32,767. Because some values for metered current, voltage, and power readings fall outside this range, the circuit monitor uses multipliers, or scale factors. This enables the circuit monitor to extend the range of metered values that it can record.

The circuit monitor stores these multipliers as scale factors. A scale factor is the multiplier expressed as a power of 10. For example, a multiplier of 10 is represented as a scale factor of 1, since $10^1=10$; a multiplier of 100 is represented as a scale factor of 2, since $10^2=100$.

You can change the default value of 1 to other values such as 10, 100, or 1,000. However, these scale factors are automatically selected when you set up the circuit monitor, either from the display or by using SMS.

If the circuit monitor displays “overflow” for any reading, change the scale factor to bring the reading back into a range that fits in the register. For example, because the register cannot store a number as large as 138,000, a 138 kV system requires a multiplier of 10. 138,000 is converted to 13,800 x 10. The circuit monitor stores this value as 13,800 with a scale factor of 1 (because $10^1=10$).

Scale factors are arranged in scale groups. The abbreviated register list in **Appendix A—Abbreviated Register Listing** on page 121 shows the scale group associated with each metered value.

You can use the command interface to change scale factors on a group of metered values. However, be aware of these important points if you choose to change scale factors:

Notes:

- We **strongly recommend** that you do not change the default scale factors, which are automatically selected by POWERLOGIC hardware and software.
- When using custom software to read circuit monitor data over the communications link, you must account for these scale factors. To correctly read any metered value with a scale factor other than 0, multiply the register value read by the appropriate power of 10.
- As with any change to basic meter setup, when you change a scale factor, all min/max and peak demand values should be reset.

GLOSSARY

accumulated energy—energy can accumulate in either signed or unsigned (absolute) mode. In signed mode, the direction of power flow is considered and the accumulated energy magnitude may increase and decrease. In absolute mode, energy accumulates as a positive regardless of the power flow direction.

address—see *device address*. See also *Ethernet address*.

ANSI—American National Standards Institute.

baud rate—specifies how fast data is transmitted across a network port.

block interval demand—power demand calculation method for a block of time and includes three ways to apply calculating to that block of time using the sliding block, fixed block, or rolling block method.

coincident readings—two readings that are recorded at the same time.

command interface—used to issue commands such as reset commands and to manually operate relays contained in registers 8000–8149.

communications link—a chain of devices such as circuit monitors and power meters that are connected by a communications cable to a communications port.

conditional energy—energy accumulates only when a certain condition occurs.

control power—provides power to the circuit monitor.

control power transformer (CPT)—transformer to reduce control power voltage to the meter.

crest factor (CF)—crest factor of voltage or current is the ratio of peak values to rms values.

current transformer (CT)—current transformer for current inputs.

current unbalance—percentage difference between each phase voltage with respect to the average of all phase currents.

default—a value loaded into the circuit monitor at the factory that you can configure.

demand—average value of a quantity, such as power, over a specified interval of time.

device address—defines where the circuit monitor (or other devices) reside in the power monitoring system.

displacement power factor (dPF)—cosine of the angle between the fundamental components of current and voltage, which represents the time lag between fundamental voltage and current.

Ethernet address—a unique number that identifies the device in the Ethernet network and is always written as combination of eleven numbers such as 199.186.195.23.

event—the occurrence of an alarm condition, such as *Undervoltage Phase A*, configured in the circuit monitor.

firmware—operating system within the circuit monitor

frequency—number of cycles in one second.

fundamental—value of voltage or current corresponding to the portion of the signal at the power frequency (50, 60, or 400 Hz).

generic demand profile—up to 10 quantities on which any of the demand calculations can be performed (thermal demand, block interval demand, or synchronized demand). Two generic demand profiles can be set up in the circuit monitor.

harmonic power—difference between total power and fundamental power. A negative value indicates harmonic power flow out of the load. A positive value indicates harmonic power flow into the load.

harmonics—the circuit monitor stores in registers the magnitude and angle of individual harmonics up to the 63rd harmonic. Distorted voltages and currents can be represented by a series of sinusoidal signals whose frequencies are multipliers of some fundamental frequency, such as 60 Hz.

holding register—register that holds the next value to be transmitted.

IEC—International Electrotechnical Commission

incremental energy—accumulates energy during a user-defined timed interval.

K-factor—a numerical rating used to specify power transformers for non linear loads. It describes a transformer's ability to serve nonlinear loads without exceeding rated temperature rise limits.

KYZ output—pulse output from a metering device where each pulse has a weight assigned to it which represents an amount of energy or other value.

LCD—liquid crystal display.

line-to-line voltages—measurement of the rms line-to-line voltages of the circuit.

line-to-neutral voltages—measurement of the rms line-to-neutral voltages of the circuit.

logging—recording data at user-defined intervals in the circuit monitor's nonvolatile memory.

maximum value—highest value recorded of the instantaneous quantity such as Phase A Current, Phase A Voltage, etc., since the last reset of the minimums and maximums.

minimum value—lowest value recorded of the instantaneous quantity such as Phase A Current, Phase A Voltage, etc., since the last reset of the minimums and maximums.

nominal—typical or average.

onboard—refers to data stored in the circuit monitor.

option cards—optional, field-installable accessories for the circuit monitor that expand the I/O and Ethernet communications capabilities because they can be inserted into slots in the circuit monitor.

overvoltage—increase in effective voltage to greater than 110 percent for longer than one minute.

parity—refers to binary numbers sent over the communications link. An extra bit is added so that the number of ones in the binary number is either even or odd, depending on your configuration). Used to detect errors in the transmission of data.

partial interval demand—calculation of energy thus far in a present interval. Equal to energy accumulated thus far in the interval divided by the length of the complete interval.

peak demand current—highest demand current measured in amperes since the last reset of demand. See also *peak value*.

peak demand real power—highest demand real power measured since the last rest of demand.

peak demand voltage—highest demand voltage measured since the last reset of demand voltage. See also *peak value*.

peak demand—highest demand measured since the last reset of peak demand.

peak value—of voltage or current is the maximum or minimum crest value of a waveform.

phase currents (rms)—measurement in amperes of the rms current for each of the three phases of the circuit. See also *peak value*.

phase rotation—phase rotations refers to the order in which the instantaneous values of the voltages or currents of the system reach their maximum positive values. Two phase rotations are possible: A-B-C or A-C-B.

potential transformer (PT)—also known as a voltage transformer

power factor (PF)—true power factor is the ratio of real power to apparent power using the complete harmonic content of real and apparent power. Calculated by dividing watts by volt amperes. Power factor is the difference between the total power your utility delivers and the portion of total power that does useful work. Power factor is the degree to which voltage and current to a load are out of phase. See also *displacement power factor*.

predicted demand—the circuit monitor takes into account the energy consumption thus far in the present interval and the present rate of consumption to predict demand power at the end of the present interval.

quantity—a parameter that the circuit monitor can measure or calculate such as current, voltage, power factor, etc.

real power—calculation of the real power (3-phase total and per-phase real power calculated) to obtain kilowatts.

recloser sequence—a series of voltage sags caused by a utility breaker opening a number of consecutive times in an effort to clear a fault. See also *sag/swell*.

rms—root mean square. Circuit monitors are true rms sensing devices. See also *harmonics (rms)*.

sag/swell—fluctuation (decreasing or increasing) in voltage or current in the electrical system being monitored. See also, *voltage sag* and *voltage swell*.

scale factor—multipliers that the circuit monitor uses to make values fit into the register where information is stored.

SMS—see System Manager Software.

synchronized demand—demand intervals in the circuit monitor that can be synchronized with another device using an external pulse, a command sent over communications, or the circuit monitor's internal real-time clock.

System Manager Software (SMS)—software designed by POWERLOGIC for use in evaluating power monitoring and control data.

system type—a unique code assigned to each type of system wiring configuration of the circuit monitor.

thermal demand—demand calculation based on thermal response.

TIF/IT—telephone influence factor used to assess the interference of power distribution circuits with audio communications circuits.

Total Harmonic Distortion (THD or thd)—indicates the degree to which the voltage or current signal is distorted in a circuit.

total power factor—see *power factor*.

transient—sudden change in the steady-state condition of voltage or current.

troubleshooting—evaluating and attempting to correct problems with the circuit monitor's operation.

true power factor—see *power factor*.

undervoltage—decrease in effective voltage to less than 90% for longer than one minute.

VAR—volt ampere reactive.

VFD—vacuum fluorescent display.

voltage interruption—complete loss of power where no voltage remains in the circuit.

voltage sag—a brief decrease in effective voltage lasting more than one minute.

voltage swell—increase in effective voltage for up to one minute in duration.

voltage transformer (VT)—see *potential transformer*.

voltage unbalance—percentage difference between each phase voltage with respect to the average of all phase voltages.

waveform capture—can be done for all current and voltage channels in the circuit monitor.

INDEX

Numerics

- 100 millisecond
 - rms event capture 103

A

- abbreviated register listing 121
- accumulate energy
 - signed or unsigned more 62
- address
 - device address 120
- alarm LED 41
- alarm levels
 - with different pickups and dropouts 81
- alarm log
 - defining storage space for 112
 - description 94
- alarms
 - abbreviated names defined 88
 - acknowledging high priority alarms 41
 - alarm conditions 78, 87
 - alarm groups 19, 78
 - alarm levels 81
 - alarm priorities described 40
 - alarm types 87–88, 90
 - alarm-triggered events 104
 - assigning priority 19
 - Boolean 78
 - creating data log entries 95
 - creating levels for multiple alarms 81
 - custom alarms 20, 82
 - introduction to 78
 - priorities 81
 - scaling alarm setpoints 85–86
 - setpoints 79
 - setup 19–23
 - types 83
 - using with waveform captures 102
 - viewing 40–41
- allocating memory 98

B

- baud rate 120
 - setup 14
- bell
 - sounding alarm with relays 82
- block interval demand method 55
- Boolean alarms 78
 - logic gates 92
- buttons
 - on the display 8

C

- calculating
 - duration of an event 80
 - watthours per pulse 76
- changing
 - date format of circuit monitor 12
 - scale factors 85
- channels
 - using to verify utility charges 60

- circuit monitor
 - accessories 3
 - described 2
 - features 3
 - instrumentation summary 2
- clock synchronized demand 57
- command interface
 - changing configuration registers 205
 - command codes 201
 - issuing commands 201
 - operating outputs 205
 - overview 200
 - registers for 200
 - scale factors 209
- command synchronized demand 57
- communications
 - problems with PC communication 120
- conditional energy
 - controlling from the command interface 206
 - register for 206
- consumption
 - pulse weight 60
 - scale factor 60
- contacting technical support 118
- contrast
 - adjusting contrast on display 9
- controlling relays 71
- correlation sequence number 80
- counting pulses with KYZ 75
- CT and PT
 - setting up ratios 16
- custom
 - alarms 82
 - quantities 27
- custom screens
 - set up 30
 - viewing 33

D

- data log 94
 - clearing the logs 94
 - forcing data log entries 111
 - memory usage 98
 - organizing log files 95
 - storage 95
 - storage in circuit monitor 117
- data storage capacity 98
- demand
 - pulse weight 60
 - scale factor 60
- demand calculation method
 - set up 18
- demand current calculation 57
- demand power calculation methods 55, 57
- demand readings 54
 - demand current 57
 - demand power calculation methods 55
 - demand voltage 57
 - generic demand 59

- input pulse demand metering 60
- peak demand 59
- predicted demand 58
- demand synch pulse method 70
- demand voltage calculation 57
- device address
 - set up of 13
- device setup in SMS 112
- diagnostics
 - performing wiring error test 44
- Diagnostics menu 43
- digital alarms 19, 78
- digital inputs 69
 - digital input alarms 78
 - input pulse demand channels 60
 - operating modes 69
 - receiving a synch pulse 57
- displacement power factor described 65
- display
 - adjusting contrast 8
 - changing values from 9
 - main menu overview 10
 - set up 11
 - using the buttons 8
- disturbance alarms 78
- disturbance monitoring
 - alarms group 19
 - and the utility company 110
 - overview 108
 - types of waveform captures 102
 - using SMS 112
- disturbance waveform capture 102
 - resolution 102
- dropout and pickup setpoints 79
- E**
- electromagnetic phenomena
 - circuit monitor capabilities 111
- energy
 - conditional energy registers 206
- energy readings 61, 63
 - reactive accumulated 63
- equipment sensitivity
 - disturbance monitoring for 110
- error messages 47
- Ethernet communications card
 - set up 14
- event
 - 100ms event capture 103
 - capturing events 105
- event log 40
 - calculating duration of event 80
 - correlation sequence number 80
 - data storage 94
 - sample entry 80
- F**
- firmware
 - determining series and firmware version 118
 - upgrades 118
- fixed block 55
- Form-C contact 75
- frequency
 - setup 16
- G**
- generic demand calculation 59
- getting technical support 118
- H**
- harmonic
 - power 65
 - setting up individual calculations 208
 - values 65
- high priority alarms 40, 81
- high speed alarms 19, 78
- Hi-Pot testing 116
- I**
- I/O
 - position numbers 204
 - viewing I/O status 42
- I/O Extender
 - set up 24
- incremental energy 207
 - interval 59
 - using with the command interface 207
- infrared port
 - communications 12
- initiating steady-state waveform captures 102
- input synchronized demand 57
- inputs
 - accepting pulse from another meter 57
 - digital input alarms 78
 - digital inputs 69
 - digital inputs operating modes 69
 - options for the I/O Extender 68
 - pulse demand metering 60
- interval min/max/average log 50, 96
- issuing commands 201
- K**
- K-factor described 64
- KYZ 74
 - calculating watt hours per pulse 76
 - counting pulses 75
 - Form-C contact 75
- L**
- labels
 - for inputs and outputs 204
- locking
 - resets 35
- logic gates for Boolean alarms 92
- logs 93
 - alarm log 94
 - clearing data logs 94
 - data log file 94
 - interval min/ax/average log 96
 - min/max log 96
 - organizing data log files 95
 - recorded maintenance data 97

- using memory 98
- low priority alarms 40, 81
- M**
- maintenance
 - maintenance log 97
 - of circuit monitor 116
 - red maintenance LED 119
- manufacture date of circuit monitor 118
- mechanical relay outputs
 - described 73
 - set up 73
- medium priority alarms 40, 81
- megger testing 116
- memory 103
 - allocation in SMS 99
 - circuit monitor memory 117
 - of circuit monitor 98
- memory allocation 98
- menu button
 - using this button 8
- menu options
 - main menu overview 10
- metered values
 - demand readings 54
 - energy readings 61
 - real-time readings 50
- metering channels 60
- min/max log 50, 96
- Min/Max menu 37–38
- monitoring
 - disturbance 108
- monitoring sags and swells 102
- motor start
 - capturing with 100 ms event recording 103
- N**
- no priority alarms 40, 81
- nonvolatile memory 98, 117
- O**
- on-board logs 93
- one-second real-time readings 50
- operation
 - green control power LED 119
 - of circuit monitor 7
 - problems with the circuit monitor 119
 - problems with the display 119
 - using the command interface 200
- outputs
 - KYZ pulse 74
 - mechanical relays 73
 - options 68
- overvoltage alarm type 83
- P**
- parity
 - set up 14
- password
 - set up 26
- peak demand calculation 59
- phase loss
 - alarm type for current 84
 - alarm type for voltage 84
- phase reversal alarm type 84
- phase rotation
 - changing 35
- pickups and dropouts
 - scale factors 85
 - setpoints 79
 - using to create alarm levels 81
- PLC
 - synchronizing demand with 57
- power analysis values 64, 66
- power demand calculation method.
 - see demand calculation method 18
- power factor 65
 - min/max conventions and example 51
 - register format 122
 - storage of 122
- power quality problems 108
- predicted demand calculation 58
- problems
 - see troubleshooting 119
- protocols
 - register addressing convention 122
- pulse initiator applications 74
 - 2-wire 75
 - 3-wire 75
- pulse weight 60
 - consumption 60
 - demand 60
- pulses
 - counting pulses with KYZ 75
- Q**
- quantities 27
 - creating demand profile using generic demand 59
 - used in alarm levels 81
- R**
- R 14
- reactive power
 - var sign convention 53
- recloser sequence
 - capturing with waveforms 103
- recording
 - data in logs 94, 96
 - events 102
 - events in the event log 111
 - events using 100ms event recording 103
- redirecting the port 14
- register
 - addressing convention 122
 - organization of bits 122
 - power factor format 122
- registers 121
 - for conditional energy 206
 - reading and writing from the display 43
 - using the command interface 205

- relay operating modes 71
 - absolute kVARh pulse 72
 - absolute kWh pulse 72
 - end of demand interval 72
 - kVAh pulse 72
 - kVAR out pulse 72
 - kVARh in pulse 72
 - kWh in pulse 72
 - kWh out pulse 72
 - latched 71
 - normal 71
 - timed 72
- relays
 - assigning multiple alarm conditions to 74
 - internal or external control of 71
 - operating using command interface 201
 - setpoint-controlled relay functions 82
 - setpoint-controlled relays 74
 - sounding bell using a relay 82
 - using with event capture 104
- resets
 - locking 35
 - of peak demand values 59
 - resetting values 36
 - values in generic demand profile 59
- reverse power alarm type 84
- rolling block 55
- route statement 120
- S**
- safety precautions
 - general 5
- sag/swell
 - description 109
- sample event log 80
- scale factor 60
 - consumption 60
 - demand 60
- scale factors 85
 - changing scale factors 209
 - scale groups 85
 - scaling alarm setpoints 86
- scale groups 85
- set up
 - alarms 19–23
 - automatic event capture 104
 - communications 12
 - CT and PT ratios 16
 - custom alarms 82
 - custom quantities 27–29
 - demand calculation method 18
 - device address 13
 - individual harmonic calculations 208
 - infrared port communications 12
 - inputs and outputs 24
 - passwords 26
 - setpoint-controlled
 - relays 82
 - setpoint-driven alarms 79–80
 - pickups and dropouts 79
 - sliding block 55
- SMS
 - device set up 112
 - using SMS 3
- standard alarms 78
- standard speed alarms 19
- steady-state waveform capture 102
 - initiating 102
- suspected errors
 - see wiring 47
- synchronizing
 - demand interval to internal clock 57
 - demand interval to multiple meters 57
 - to PLC command 57
- System Manager Software
 - see SMS.
- system type
 - set up 16
- T**
- TDD described 64
- technical support 118
- testing
 - dielectric (hi-pot) test 116
 - megger test 116
 - wiring test 44
- THD
 - changing to thd 35
 - thd calculation method 64
- thermal demand method 58
- Total Demand Distortion 64
- total harmonic distortion 64, 102
- transients 108
- troubleshooting 119
- types of alarms 90
- U**
- unbalance current alarm type 83
- unbalance voltage alarm type 84
- undervoltage alarm type 83
- upgrading
 - firmware 118
- V**
- VAR sign convention 53
 - changing 33
- verifying utility charges 60
- viewing metered data 37
- voltage disturbance monitoring 108
- voltage sag 109
 - circuit monitor capabilities during 111
 - using waveform captures to detect 109
- voltage swell
 - circuit monitor capabilities during 111
- W**
- watthours
 - calculating watthours per KYZ pulse 76
- waveform captures
 - 100 ms event recording 103

- circuit monitor memory 105
- disturbance waveform captures 102
- relay-triggered events 104
- steady-state waveform captures 102
- storage of waveforms 104
- types 102
- using memory 98
- using to detect voltage sag 109
- wiring
 - test error messages 47
 - troubleshooting 44, 120

