

# Magelis Compact iPC Industrial PCs User Manual

eng November 2004



---

---

# Table of Contents

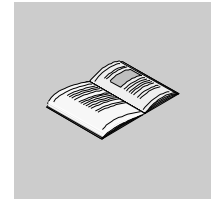

---

	<b>Safety Information</b> .....	<b>5</b>
	<b>About the Book</b> .....	<b>17</b>
<b>Part I</b>	<b>General overview</b> .....	<b>19</b>
	At a Glance .....	19
<b>Chapter 1</b>	<b>Introduction</b> .....	<b>21</b>
	Introduction .....	21
<b>Chapter 2</b>	<b>Physical overview</b> .....	<b>23</b>
	At a Glance .....	23
	Package Contents .....	24
	Compact 667 MHz and Pentium 4 description .....	25
<b>Chapter 3</b>	<b>Characteristics</b> .....	<b>27</b>
	At a Glance .....	27
	Characteristics of the 667 MHz Compact iPC .....	28
	Characteristics of the Pentium 4 Compact iPC .....	31
	Environment characteristics .....	33
<b>Part II</b>	<b>Implementation</b> .....	<b>35</b>
	At a Glance .....	35
<b>Chapter 4</b>	<b>Main Power Connection</b> .....	<b>37</b>
	At a Glance .....	37
	Connecting the AC Power Cord .....	38
	DC Version wiring .....	41
	Grounding Cautions .....	44
	Connecting I/O Signal Lines .....	45
	Control drawing of the USB outlet on the Magelis iPC front panel .....	46
<b>Chapter 5</b>	<b>Getting started</b> .....	<b>49</b>
	First power-up .....	49
<b>Chapter 6</b>	<b>Hardware extensions</b> .....	<b>51</b>

---

---

	At a Glance . . . . .	51
	Before installation . . . . .	52
	Removing the Compact iPC Unit's Cover . . . . .	53
	Compact 667 MHz iPC internal view . . . . .	54
	Compact P4 iPC Internal View. . . . .	55
	Main Memory Installation. . . . .	57
	Expansion Board (PCI) Installation . . . . .	58
	PCMCIA Unit Installation . . . . .	60
	CF Card Installation and Removal. . . . .	62
<b>Chapter 7</b>	<b>Configuration of the Bios . . . . .</b>	<b>65</b>
	At a Glance . . . . .	65
	Accessing the Bios configuration of the Compact 667 MHz iPC . . . . .	66
	Standard CMOS Features for the Compact 667 MHz iPC. . . . .	67
	Accessing the Bios configuration of the Pentium 4 iPC . . . . .	69
	Standard CMOS Features for the Pentium 4 iPC . . . . .	70
<b>Chapter 8</b>	<b>Maintenance . . . . .</b>	<b>73</b>
	At a Glance . . . . .	73
	Reinstallation . . . . .	74
	Cleaning. . . . .	75
<b>Part III</b>	<b>Installation . . . . .</b>	<b>79</b>
	At a Glance . . . . .	79
<b>Chapter 9</b>	<b>Dimension/Assembly. . . . .</b>	<b>81</b>
	At a Glance . . . . .	81
	Dimensions . . . . .	82
	Cropping for Cabinet Installation . . . . .	84
	Panel Mounting . . . . .	85
	Installing the Compact iPC Unit . . . . .	86
<b>Chapter 10</b>	<b>Connections to PLCs. . . . .</b>	<b>93</b>
	Connection to PLCs. . . . .	93
<b>Part IV</b>	<b>Appendices . . . . .</b>	<b>95</b>
	At a Glance . . . . .	95
<b>Chapter 11</b>	<b>Accessories . . . . .</b>	<b>97</b>
	Accessories . . . . .	97

---

# Safety Information

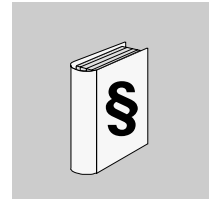

---

## General safety information for users

### General

The present documentation is aimed at qualified technical personnel responsible for the implementation, operation and maintenance of the products described. It contains the information necessary for compliance with the proper use of the products. However, those who wish to make more "advanced" use of our products may find it necessary to consult our nearest distributor in order to obtain additional information.

**The contents of this documentation are not contractual, and in no way constitutes an extension to, or restriction of, the contractual warranty clauses.**

### Personnel qualifications

Only **qualified personnel** are authorized to implement, operate or maintain the products. The interference of non-qualified persons or failure to observe the security instructions contained in this manual, or attached to the devices, can endanger the personnel and/or do irreparable damage to the equipment. The following persons can be designated as "**qualified personnel**":

- at application design level, engineering department personnel who are familiar with automation safety concepts (for example, a design engineer),
  - at equipment implementation level, personnel who are familiar with the installation, connection and commissioning of automation equipment (for example, an installation assembly or cabling engineer, or a commissioning technician),
  - at operation level, personnel who are experienced in the use and control of automation and computing equipment (for example, an operator),
  - as far as preventive or corrective maintenance is concerned, persons trained and qualified in regulating or repairing automatic and computing devices (for example an operating technician, or an after-sales service technician, etc.).
-

**Switching off**

Control software such as is typically used on Industrial PCs permits various users to be given different rights. A user who may not close software may also not switch the Industrial PC off, since data can be lost from the hard disk by switching off while software is running.

If the Industrial PC is switched off as the software is writing a file to the hard disk, the file can be destroyed. Control software typically writes data to the hard disk every few seconds, so that the probability of causing damage by switching off while the software is running is very high.

To avoid that please respect the instructions of the operation system for closing the softwares and switching off the Industrial PC.

---

**Compliance of use**

The products described in the present documentation **comply with the European Directives\*** to which they are subject (EC marking). However, these can only be used correctly if in applications for which they are specifically intended, as specified in the relevant documentation, and in connection with approved third-party products. As a general rule, correct usage of the products, with no danger to personnel or hardware, consists of complying with all handling, transport and storage recommendations, and all installation, operation and maintenance instructions.

\* EMCD and LVD directives concerning Electromagnetic Compatibility and Low Voltage.

---

**Replacement and recycling of used batteries**

Replace batteries with those of the same type, and dispose of any defective batteries in the same way as toxic waste.

Lithium or mercury batteries must not be thrown into a fire, opened, recharged or welded.

---

**Lithium battery**

The terminal contains a lithium battery, which is used to save certain data such as the date and time.

This must only be replaced by a qualified technician.

---

	<b>WARNING</b>
	Non-compliance with this warning may lead to a risk of explosion! <b>Failure to follow this precaution can result in death, serious injury, or equipment damage.</b>

---

**Federal  
Communications  
Commission  
Radio Frequency  
Interference  
Statement - For  
U.S.A.**

This equipment has been tested and found to comply with the limits for a Class A digital device, pursuant to Part 15 of the FCC Rules. These limits are designed to provide reasonable protection against harmful interference in a residential installation. This equipment generates, uses and can radiate radio frequency energy and, if not installed and used in accordance with the instructions, may cause harmful interference to radio communications. However, there is no guarantee that interference will not occur in a particular installation. If this equipment does cause harmful interference to radio or television reception, which can be determined by turning the equipment off and on, the user is encouraged to try to correct the interference by one or more of the following measures:

- Reorient or relocate the receiving antenna.
- Increase the separation between the equipment and receiver.
- Connect the equipment into an outlet on a circuit different from that to which the receiver is connected.
- Consult the Support Service Center or an experienced radio/TV technician for help.

**WARNING**



To assure continued compliance, use only shielded interface cables when connecting to a computer or peripheral. Also, any changes or modifications not expressly approved by the party responsible for compliance could void the user's authority to operate this equipment. This device complies with Part 15 of the FCC Rules. Operation is subject to the following two conditions:

- This device may not cause harmful interference received, including interference that may cause undesired operation.
- This device must accept any interference received, including interference that may cause undesired operation.

**Failure to follow this precaution can result in death, serious injury, or equipment damage.**

## Safety Warnings

- For U.K.

	<b>WARNING</b>
	<p><b>This apparatus must be earthed for your safety.</b></p> <p>To ensure safe operation the three-pin plug must be inserted only into a standard three-pin power point, which is effectively earthed through the normal household wiring. Extension cords used with the equipment must be three-core and be correctly wired to provide connection to earth. Wrongly wired extension cords are a major cause of fatalities. The fact that the equipment operates satisfactorily does not imply that the power point is earthed and that the installation is completely safe.</p> <p>For your safety, if you have any doubt about the effective earthing of the power point, consult a qualified electrician.</p> <p><b>Failure to follow this precaution can result in death, serious injury, or equipment damage.</b></p>

	<b>WARNING</b>
	<p><b>THIS APPLIANCE MUST BE EARTHED</b></p> <p><b>Important</b></p> <p>The wires in this mains lead are coloured in accordance with the following code:</p> <ul style="list-style-type: none"><li>● Green-and-yellow: Earth</li><li>● Blue: Neutral</li><li>● Brown: Live</li></ul> <p>As the colours of the wires in the mains lead of this apparatus may not correspond with the coloured markings identifying the terminals in your plug, proceed as follows:</p> <p>The wire which is coloured GREEN-and-YELLOW must be connected to the terminal in the plug which is marked by the letter E or by the safety earth symbols coloured GREEN or GREEN-and-YELLOW.</p> <p>The wire which is coloured Blue must be connected to the terminal which is marked with the letter N or coloured BLACK.</p> <p>The wire which is coloured Brown must be connected to the terminal which is marked with the letter L or coloured RED.</p> <p>The mains plug on this equipment must be used to disconnect the mains power. Please ensure that a socket outlet is available near the equipment and is easily accessible.</p> <p><b>Failure to follow this precaution can result in death, serious injury, or equipment damage.</b></p>



	<b>WARNING</b>
	<ul style="list-style-type: none"><li>• This equipment is not designed for connection to an IT power system: An IT system is a system having no direct connections between live parts and Earth; the exposed conductive parts of the electrical installation are earthed. An IT system is not permitted where the computer is directly connected to public supply systems in the UK.</li><li>• Disconnect the mains plug from the supply socket when the computer is not in use.</li></ul> <p><b>Failure to follow this precaution can result in death, serious injury, or equipment damage.</b></p>

**Warnung Für  
Deutschland****Warnung bezüglich der Lithiumbatterie (Sicherungsbatterie)**

Lithiumbatterie

Dieser Computer enthält eine Lithiumbatterie zur Sicherung von Datum und Uhrzeit der eingebauten Uhr sowie anderer Systemdaten im Speicher bei einer Unterbrechung der Hauptstromversorgung. Diese Sicherungsbatterie darf nur von Kundendienstpersonal ausgewechselt werden.

Warnung! Bei falschem Gebrauch besteht Explosionsgefahr!

Entsorgung gebrauchter Batterien nach Angaben des Herstellers.

## Hazardous Location Installations - for USA and Canada

### General

Schneider Automation designed the systems with the intention of meeting the requirements of Class 1, Division 2 hazardous location applications. Division 2 locations are those locations that are normally non-hazardous, but potentially hazardous should an accident expose the area to flammable vapors, gases or combustible dusts.

These systems are non-incendiary devices. They are not intrinsically safe and should never be operated within a Division 1 (normally hazardous) location when installed as described here. Nor should any peripheral interface device attached to these systems be located within Division 1 locations unless approved and/or certified diode barriers are placed in series with each individual signal and DC power line. Any such installations are beyond the bounds of Schneider Automation design intent. Schneider Automation accepts no responsibility for installations of this equipment or any devices attached to this equipment in Division 1 locations.

**It is mandatory to install the Hazardous Location kit.**

### Warning

For AC version equipment only:  
the power switch is in arcing device. It should be switched to the ON position and the corresponding retainer bracket for the Control Box should be attached according to the Hazardous Location Kit service instruction

Only technically qualified service personnel should perform installation and service. These workstations are designed to require no service in the course of normal operation by an operator.

### Warning

It is the user's responsibility in case of maintenance or repair of any subassembly to verify that the exchanged or repaired module is labelled as a Class I Division 2 hazardous location.

It is the responsibility of the customer to ensure that the product is properly rated for the location. If the intended location does not presently have a Class, Division and Group rating, then users should consult the appropriate authorities having jurisdiction in order to determine the correct rating for that hazardous location.

In accordance with Federal, State/Provincial, and Local regulations, all hazardous location installations should be inspected prior to use by the appropriate authority having jurisdiction. Only technically qualified personnel should install, service, and inspect these systems.

**Warning**

Suitable for use in Class I, Division 2 Groups A, B, C, and D, hazardous locations or non-hazardous locations only.

**Warning - Explosion Hazard**

Substitution of components may impair suitability for Class I, Division 2.

**Warning**

For a use in hazardous locations, the PCI or ISA controller cards shall be found in category NWH2, provided that they are suitable for Class I, Division 2, Groups A, B, C, and D; T-code:T4A, and suitable for an ambient temperature range of +0°C to +50°C.

**Warning - Explosion Hazard**

Do not connect or disconnect equipment unless the power has been switched off or the area is known to be non-hazardous.

**Warning**

Power wiring must be in accordance with the National Electrical Code article 501.4(B) for Class I, Division 2.

**Warning - Explosion Hazard**

When in hazardous locations, turn off power before replacing or wiring modules.

**Warning - Explosion Hazard**

Do not connect or disconnect the output ports such as PS2/USB/Serial/Parallel/LAN/Audio connectors, when the unit is in a Hazardous Location area

**Definition**

The following Class and Division explanations are derived from Article 500 (Sections 5 and 6) of the United States National Fire Protection Agency National Electric Code (NFPA 70, 1990). They are not complete and are included here only for a general description for those not familiar with generic hazardous locations requirements. Persons responsible for the installation of this equipment in hazardous locations are responsible for ensuring that all relevant codes and regulations related to location rating, enclosure, and wiring are met.

**Class I Locations**

Class I locations are those in which flammable gases or vapors are or may be present in the air in quantities sufficient to produce explosive or ignitable mixtures.

**Class II Locations**

Class II locations are those that are, or may become, hazardous because of the presence of combustible dust.

**Division 1 Locations**

A Division 1 location is one in which flammable or ignitable gases, vapors or combustible dusts and particles can exist due the following conditions:

- Normal operating conditions.
- Due to repair, maintenance conditions, leakage, or where mechanical failure or abnormal operation of machinery or equipment might release or cause explosive or ignitable mixtures to be released or produced.
- Combustible dusts of an electrically conductive nature may be present in hazardous quantities.

**Note**

Schneider Automation MPC••• systems are not suitable for installation within Class II Division 2 and Class 1 Division 1 locations.

**Note**

Electrical equipment cannot be installed in Division 1 locations unless they are intrinsically safe, installed inside approved explosion-proof enclosures, or installed inside approved purged and pressurized enclosures.

**Division 2 Locations**

- Class I volatile flammable liquids or flammable gases are handled, processed or used, but confined within closed containers or closed systems from which they can escape only in cases of accidental rupture or breakdown of such enclosures or systems, or in case of abnormal operation of equipment.
- Ignitable concentrations of Class I vapors or gases are normally prevented by positive mechanical ventilation, but may become hazardous due to mechanical failure of those ventilation systems.
- Location is adjacent to a Division 1 location.
- Class II combustible dust is not normally in the air in quantities sufficient to produce explosive or ignitable mixtures. Dust accumulations are normally insufficient to interfere with normal operation of electrical equipment or other apparatus. Combustible dust may be in suspension in the air as a result of the following: infrequent malfunctioning of handling or processing equipment; combustible dust accumulations on, or in the vicinity of, electrical equipment; may be ignitable by abnormal operation or failure of electrical equipment.

**Groups**

All electrical equipment that is approved for use in hazardous locations must include a group rating. Various flammable and combustible substances are divided into these groups as a function of their individual maximum experimental safe gap (MESG), explosion pressure, and ignition temperature. Component temperatures and the potential for spark based upon voltage, current and circuit characteristics of electrical equipment will determine what the equipment group rating will be. A device approved for installation within Class I, Group A locations may also be used in Groups B, C, or D.

**Note**

Approved Class I equipment may not be suitable for Class II installations. Class I includes Groups A, B, C, and D. Class II includes Groups F, and G.

**Power Switch**

The amount of input power required by these systems classifies a power switch as an incendiary device because the voltage and current across the make/break device are capable of creating a spark.

Hazardous location regulations require that a power switch rated for ordinary locations may be used if it is located in an area specified as non-hazardous. However, limits in cable length between the workstation and the power switch may apply. Otherwise the switch must be compliant with Class I, Division 1 requirements (intrinsically safe). These switches are built in a manner that prevents the possibility of a spark when contacts are made or broken.

Use suitable UL listed and/or CSA Certified Class I, Division 1 switches in hazardous locations. These switches are available from a wide number of sources. It is the responsibility of the customer to ensure that the power switch selected for the installation has the correct hazardous locations rating for the location in which it is installed.

**Cable connections**

Division 2 hazardous location regulations require that all cable connections be provided with adequate strain relief and positive interlock. USB connections can never be used in hazardous location installations, because USB connectors do not provide adequate strain relief. Never connect or disconnect a cable while power is applied at either end of the cable. All communication cables should include a chassis ground shield. This shield should include both copper braid and aluminum foil. The D-sub style connector housing should be a metal conductive type (e.g., molded zinc) and the ground shield braid should be well terminated directly to the connector housing. Do not use a shield drain wire.

The outer diameter of the cable must be suited to the inner diameter of the cable connector strain relief in order to ensure that a reliable degree of strain relief is maintained. Always secure the D-Sub connectors to the workstation-mating connectors via the two screws located on both sides.

**Warning**

Never connect or disconnect the communication cables while power is applied at either end of the cable. This may result in an incendiary spark. Permanent damage to the workstation communication components may occur.

---

**Operation and Maintenance**

The systems have been designed for compliance with relevant spark ignition tests. However, please note that the workstation front panel keypad switches and PS/2 connector are the only make/break components intended to be exercised by the operator in the course of normal operation.

**Warning - Explosion Hazard**

The front USB connector provides non incensive field circuit when connected in accordance with control drawing located in chapter 4.

Always observe the following rules with respect to hazardous location installations:

- Always install the workstations within an enclosure suitable for the specific application. General-purpose enclosures may be acceptable for Class I applications but are never acceptable for Class II applications. Type 4 (IP 65) enclosures are recommended even when not required by regulations.
- If present, keep enclosure doors or openings closed at all times, to avoid the accumulation of foreign matter inside the workstation.
- Never subject the unit to any installation or service procedures unless power is removed and the area is known to be non-hazardous. This includes the installation or removal of power cables, communication cables, or removal of the rear cover of the unit.

---

**Safety Agency Approval**

The Schneider Automation systems are designed to meet the following standards:

- Underwriters Laboratories Inc., UL 1604 Standard for Safety Electrical equipment for use in Class I Division 2 locations
  - Underwriters Laboratories Inc., UL 60950, Information Technology Equipment
  - Canadian Standard Association, Specification C22.2 No. 213-M1987 Non-incendiary electrical equipment for use in Class I, Division 2 hazardous locations.
  - Canadian Standards Association, Specification C22.2 No. 950 Information Technology Equipment
  - EN 60950, Information Technology Equipment
-





---

## About the Book

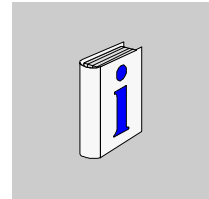

---

### At a Glance

**Document Scope** This manual describes the use of the Magelis Compact iPC of industrial PCs.

### Related Documents

Title of Documentation	Reference Number
Magelis Smart & Compact iPC installation guide	35008589

**User Comments** We welcome your comments about this document. You can reach us by e-mail at [techpub@schneider-electric.com](mailto:techpub@schneider-electric.com)

---



---

# General overview

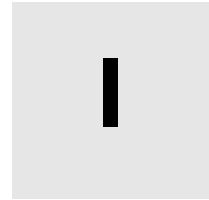

---

## At a Glance

### Subject of this part

This part provides an overview of the Magelis Compact iPC products.

### What's in this Part?

This part contains the following chapters:

Chapter	Chapter Name	Page
1	Introduction	21
2	Physical overview	23
3	Characteristics	27



---

# Introduction



---

## Introduction

### Thank you

Congratulations!

Thank you for having purchased an industrial computer from the Magelis Compact iPC range.

This computer, designed to operate in an industrial environment, features the very latest technologies.

---

### At a Glance

Magelis Compact iPC computers are standalone products.

There are 4 versions of Compact iPC.

- References: MPC KT 52 NA.00.  
15" XGA Touch screen  
AC voltage processor VIA 667MHz
- References: MPC KT 55 NA.00.  
15" XGA Touch screen  
AC voltage processor Pentium 4 1,7GHz
- References: MPC KT 52 ND.00.  
15" XGA Touch screen  
DC voltage processor VIA 667MHz
- References: MPC KT 55 ND.00.  
15" XGA Touch screen  
DC voltage processor Pentium 4 1,7GHz

The characteristics are detailed in chapter 3

---



---

# Physical overview



# 2

---

## At a Glance

### Subject of this chapter

This chapter provides physical overviews of the products.

### What's in this Chapter?

This chapter contains the following topics:

Topic	Page
Package Contents	24
Compact 667 MHz and Pentium 4 description	25





---

## Package Contents

---

**Items**

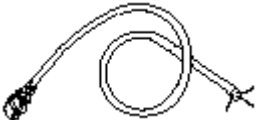
The following items are included in the Compact Magelis iPC package. Before using the Magelis iPC (MPC), please confirm that all items listed here are present.

Designation	Figure
MPC KT5.NA.00.	
Installation Fasteners (4/set x 2)	
AC Power Cord	
CD-ROM + Recovery Floppy Disk OS restore and bundled softwares (optional)	
Installation Guide (French/English)	

This unit has been carefully packed, with special attention to quality. However, should you find anything damaged or missing, please contact your local distributor immediately.

---



## Compact 667 MHz and Pentium 4 description

### Features

View	Figure	Legend												
Front		<p>1 : Display / Touch Panel 2 : Power Lamp LED (POWER)</p> <table border="1"> <thead> <tr> <th>LED</th> <th>Status</th> </tr> </thead> <tbody> <tr> <td>Green</td> <td>Normal Operation (Power On)</td> </tr> <tr> <td>Orange</td> <td>System Monitor Error Touch Panel Self Test Error</td> </tr> <tr> <td>Orange/Red</td> <td>Backlight is not functioning</td> </tr> </tbody> </table> <p>3 : IDE Access Lamp</p> <table border="1"> <thead> <tr> <th>LED</th> <th>Status</th> </tr> </thead> <tbody> <tr> <td>Green</td> <td>Normal Operation</td> </tr> </tbody> </table> <p>4 : Front Packing 5 : Hardware Reset Switch (RESET) Pressing this switch re-starts the unit 6 : USB Connector (1 port) Provides a USB 1.1 compatible connection Connect a USB connectable device here</p>	LED	Status	Green	Normal Operation (Power On)	Orange	System Monitor Error Touch Panel Self Test Error	Orange/Red	Backlight is not functioning	LED	Status	Green	Normal Operation
LED	Status													
Green	Normal Operation (Power On)													
Orange	System Monitor Error Touch Panel Self Test Error													
Orange/Red	Backlight is not functioning													
LED	Status													
Green	Normal Operation													
Rear		<p>7 : Expansion Board Locker</p>												
Side		<p>8 : FD Drive 9 : CD-ROM Drive 10 : PCMCIA Connectors (PCMCIA) (2 ports)</p>												

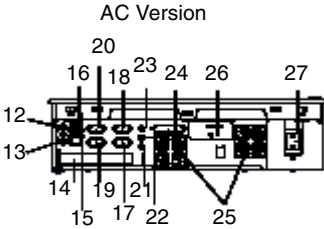
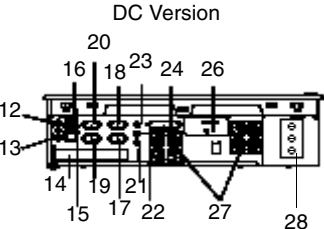
View	Figure	Legend
Top	 <p>11</p>	<p>11 : Rear Cover This cover is removed when installing an main memory, or Expansion Unit (PCI)</p>
Bottom	<p>AC Version</p>  <p>DC Version</p> 	<p>12 : Mouse Connector (MOUSE) Connect a PS/2-compatible mouse here</p> <p>13 : Keyboard Connector (KEYBOARD) Connect a PS/2-compatible keyboard here</p> <p>14 : PCI Slot</p> <p>15 : LAN Connector (LAN) (10 BASE-T/100 BASE-TX)</p> <p>16 : USB Connectors (2 ports) Connect a USB connectable device here</p> <p>17 : RS-232C Connector (COM 1)</p> <p>18 : RS-232C Connector (COM 2)</p> <p>19 : RS-232C Connector (COM 3)</p> <p>20 : RS-232C Connector Not available (Used by touch screen)</p> <p>21 : Line Input Connector (LINE IN)</p> <p>22 : Speaker Output Connector (SPEAKER OUT)</p> <p>23 : Mike Input Connector (MIC IN)</p> <p>24 : Printer Connector (LPT1)</p> <p>25 : Cooling Fan</p> <p>26 : CF Card Slot</p> <p>27 : AC Inlet Connector</p> <p>28 : DC Terminal block</p>

---

# Characteristics



# 3

---

## At a Glance

### Subject of this chapter

This chapter gives the product characteristics.

### What's in this Chapter?

This chapter contains the following topics:

Topic	Page
Characteristics of the 667 MHz Compact iPC	28
Characteristics of the Pentium 4 Compact iPC	31
Environment characteristics	33

## Characteristics of the 667 MHz Compact iPC

---

### Introduction

The different characteristics of the 667 MHz Compact iPC model are given below.

---

### CPU characteristics

Element	Characteristics
Processor	VIA 667 MHz, secondary memory cache 512 KB
RAM	DIMM Socket 1: 256 MB / 512 MB (max 512 MB)
Hard disk	Capacity greater or equal to 20 Gb IDE 2"1/2
Video processor	VIA Twister-T with 32 Mb ram UMA type
Diskette drive	3.5", 1.44 Mb
CD-ROM drive	24x
Ethernet TCP/IP link	1 x 10/100base TX (RJ45 interface)
PS/2 ports	1 keyboard and 1 mouse interface
USB ports	Front socket: USB 1.1, bottom sockets: 2 x USB 1.1
COM 1 serial port	RS232C
COM 2 serial port	RS232C
COM 3 serial port	RS232C
Parallel port	1 bi-directional link
Extension card slot	1 PCI 2.2 interface slot
Memory flash card slot	CompactFlash type
PCMCIA slot	2 ports Type 2 on side
Audio port	Speaker out, Line in and Micro in (standard jack interface)
Dimensions (WxHxD)	395 mm x 294 mm x 100 mm
Weight	8.0 Kg

---

**Display characteristics**

Element	Characteristics
Graphics	XGA active matrix (1024x768 dots), VESA max. 64 K colors
Nb of colors	260 K colors
Brightness	250 cd/m (typical value, adjust through Windows® 4 steps)
View angle	Vertical 140°, horizontal 160° maximum
Touch sensitive screen	Analog resistive film, resolution 1024x1024, COM4 interface
Backlight's life span	>50 000 h at ambient temperature 25 °C

	<b>CAUTION</b>
	<p><b>COM4 interface.</b></p> <p>You must not use the COM4 interface to connect any device.</p> <p><b>Failure to follow this precaution can result in injury or equipment damage.</b></p>

**Power supply**

**AC Version**

Element	Characteristics
Supply voltage	115-230 V AC 50/60 Hz, (range 85...264 V AC)
Frequency	50/60 Hz (range 47...63 Hz), EN61131-2 compliant
Consumption	120 VA
Short dips	10 ms
PCI expansion slot capability	Board size 240x106x68 mm DC 5 V: 1.5 A, DC 12 V: 0.5 A, DC 12 V: 0.1 A, DC 3.3 V: 0.5 A

**DC Version**

Element	Characteristics
Supply voltage	24 V DC (range 18...36 V)
Frequency	50/60 Hz (range 47...63 Hz), EN61131-2 compliant
Consumption	120 W
Short dips	1 ms

**Operating systems**

The products are delivered with a pre-installed operating system according to the reference ordered.

the products have been tested with the following operating systems :

- Microsoft Windows 2000,
  - Microsoft Windows XP embedded.
- 

**Pre-installed packs**

Element	Characteristics
MPC KT52 NAA 00N	15" XGA TS AC 667 MHz - Win2K, no pre-installed pack
MPC KT52 NAA 00A	15" XGA TS AC 667 MHz - Win2K / VijeoLook2.5 RT
MPC KT52 NAX 00N	15" XGA TS AC 667 MHz - WinXPe, no pre-installed pack
MPC KT52 NAX 00A	15" XGA TS AC 667 MHz - WinXPe / VijeoLook2.5 RT
MPC KT52 NDA 00N	15" XGA TS DC 667 MHz - Win2K, no pre-installed pack
MPC KT52 NDA 00A	15" XGA TS DC 667 MHz - Win2K / VijeoLook2.5 RT
MPC KT52 NDX 00N	15" XGA TS DC 667 MHz - WinXPe, no pre-installed pack
MPC KT52 NDX 00A	15" XGA TS DC 667 MHz - WinXPe / VijeoLook2.5 RT

---

## Characteristics of the Pentium 4 Compact iPC

### Introduction

The different characteristics of the Pentium 4 Compact iPC model are given below.

### CPU characteristics

Element	Characteristics
Processor	Pentium 4 1,7 GHz, secondary memory cache 512 KB
RAM	DIMM Socket 1: 256 MB / 512 MB (max 512 MB)
Hard disk	Capacity greater or equal to 20 Gb IDE 2"1/2
Video processor	Intel 828456 with 64 Mb ram UMA type
Diskette drive	3.5", 1.44 Mb
CD-ROM drive	24x
Ethernet TCP/IP link	1 x 10/100base TX (RJ45 interface)
PS/2 ports	1 keyboard and 1 mouse interface
USB ports	Front socket: USB 1.1, bottom sockets: 2 x USB 1.1
COM 1 serial port	RS232C
COM 2 serial port	RS232C
COM 3 serial port	RS232C
Parallel port	1 bi-directional link
Extension card slot	1 PCI 2.2 interface slot
Memory flash card slot	CompactFlash type
PCMCIA slot	2 ports Type 2 on side
Audio port	Speaker out, Line in and Micro in (standard jack interface)
Dimensions (WxHxD)	395 mm x 294 mm x 100 mm
Weight	8.0 Kg

### Display characteristics

Element	Characteristics
Graphics	XGA active matrix (1024x768 dots), VESA max. 64 K colors
Nb of colors	260 K colors
Brightness	250 cd/m (typical value, adjust through Windows® 4 steps)
View angle	Vertical 140°, horizontal 160° maximum
Touch sensitive screen	Analog resistive film, resolution 1024x1024, COM4 interface
Backlight's life span	>50 000 h at ambient temperature 25 °C

**Power supply**

**AC Version**

Element	Characteristics
Supply voltage	115-230 V AC 50/60 Hz, (range 85...264 V AC)
Frequency	50/60 Hz (range 47...63 Hz), EN61131-2 compliant
Consumption	150 VA
Short dips	10 ms
PCI expansion slot capability	Board size 240x106x68 mm DC 5 V: 1.5 A, DC 12 V: 0.5 A, DC 12 V: 0.1 V, DC 3.3 V: 0.5 A

**DC Version**

Element	Characteristics
Supply voltage	24 V DC, (range 18...36 V)
Frequency	50/60 Hz (range 47...63 Hz), EN61131-2 compliant
Consumption	150 W
Short dips	1 ms

**Operating systems**

The products are delivered with a pre-installed operating system according the reference ordered.

the products have been tested with the following operating systems :

- Microsoft Windows 2000,
- Microsoft Windows XP embedded.

**Pre-installed packs**

Element	Characteristics
MPC KT55 NAA 00N	15" XGA TS AC Pentium 4 1.7 Ghz - Win2K, no pre-installed pack
MPC KT55 NAA 00A	15" XGA TS AC Pentium 4 1.7 Ghz - Win2K / VijeoLook2.5 RT
MPC KT55 NAA 00B	15" XGA TS AC Pentium 4 1.7 Ghz - Win2K / VijeoLook2.5 BT
MPC KT55 NAX 00N	15" XGA TS AC Pentium 4 1.7 Ghz - WinXPe, no pre-installed pack
MPC KT55 NAX 00A	15" XGA TS AC Pentium 4 1.7 Ghz - WinXPe / VijeoLook2.5 RT
MPC KT55 NAX 00B	15" XGA TS AC Pentium 4 1.7 Ghz - WinXPe / VijeoLook2.5 BT
MPC KT55 NDA 00N	15" XGA TS DC Pentium 4 1.7 Ghz - Win2K, no pre-installed pack
MPC KT55 NDA 00A	15" XGA TS DC Pentium 4 1.7 Ghz - Win2K / VijeoLook2.5 RT
MPC KT55 NDA 00B	15" XGA TS DC Pentium 4 1.7 Ghz - Win2K / VijeoLook2.5 BT
MPC KT55 NDX 00N	15" XGA TS DC Pentium 4 1.7 Ghz - WinXPe, no pre-installed pack
MPC KT55 NDX 00A	15" XGA TS DC Pentium 4 1.7 Ghz - WinXPe / VijeoLook2.5 RT
MPC KT55 NDX 00B	15" XGA TS DC Pentium 4 1.7 Ghz - WinXPe / VijeoLook2.5 BT



## Environment characteristics

**General** The environment characteristics given below are applicable to the products.

**Characteristics** The environment characteristics are as follows:

Characteristics	Value	Standards
<b>Degree of Protection</b>	<ul style="list-style-type: none"> <li>● IP 65 for the front panel.</li> <li>● IP 20 for the rest of the product</li> </ul>	-
<b>Operating temperature</b>	0 °C to 50 °C	EN 61131-2, UL compliant
<b>Storage temperature</b>	-20 °C to 60 °C	IEC 68-2-2 tests Bb and Ab, IEC 68-2-14 tests Na and EN 61131-2 compliant
<b>Operating altitude</b>	0 to 3000 m maximum	-
<b>Storage altitude</b>	0 to 12000 m maximum	-
<b>Vibration</b> (in operation)	3,5mm amplitude from 5 to 9 Hz, 1g amplitude from 9 to 150 Hz	IEC 68-2-6 Fc test and EN 61131-2 compliant
<b>Shock Resistance</b> (in operation)	15g over 11ms	IEC 68-2-27 Ea test and EN 61131-2 compliant
<b>Hygrometry</b>	10 - 90 %	-
<b>Immunity to interference</b>	High frequency interference	EN 61131, IEC 1000-4-3/6 level 3
	Electromagnetic waves	Class A/EN 55022/55011
	Safety of personnel and property	EN 61131-2, UL/CSA and IEC 529/IEC 950

**Certification** The products have been developed to comply with the following standards:

- UL 508
- IEC/EN 60950
- EN 55022
- IEC/EN 61131-2
- CUL
- Classification in Hazardous Areas: CLASS1 - DIVISION2 - UL 1604



---

# Implementation

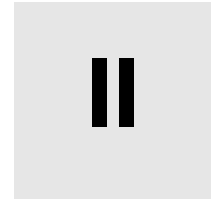

---

## At a Glance

### Subject of this part

This part concerns the implementation of products.

### What's in this Part?

This part contains the following chapters:

Chapter	Chapter Name	Page
4	Main Power Connection	37
5	Getting started	49
6	Hardware extensions	51
7	Configuration of the Bios	65
8	Maintenance	73



---

# Main Power Connection



---

## At a Glance

### Subject of this chapter

This chapter concerns the connection of the products to the main power.

### What's in this Chapter?

This chapter contains the following topics:

Topic	Page
Connecting the AC Power Cord	38
DC Version wiring	41
Grounding Cautions	44
Connecting I/O Signal Lines	45
Control drawing of the USB outlet on the Magelis IPC front panel	46

## Connecting the AC Power Cord

---

### Installing the AC Power Cord

Insert the power cord (AC inlet plug) into the Compact iPC's bottom face AC connector.

---

### AC Connector Illustration

The figure below presents the AC Connector

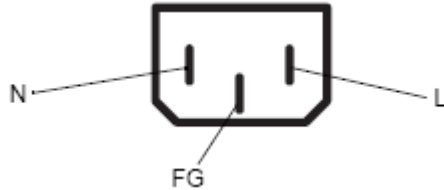

### AC Connector Description

Description

Number	Description
L	AC Input Terminal-live line
N	AC Input Terminal-neutral line
FG	Ground Terminal connected to the Compact iPC chassis

---

### Precaution

	<p><b>WARNING</b></p>
	<p>To avoid an electric shock, check that the main power supply is turned OFF, via a breaker, or similar unit before connecting the Compact iPC's power cord to the AC connector.</p> <p>To avoid the dangers of fire, electric hazards and equipment damage, be sure to use only the specified voltage when operating the unit.</p> <p><b>Failure to follow this precaution can result in death, serious injury, or equipment damage.</b></p>

---

**Cord Clamp  
Illustration**

The figure below presents the cord clamp

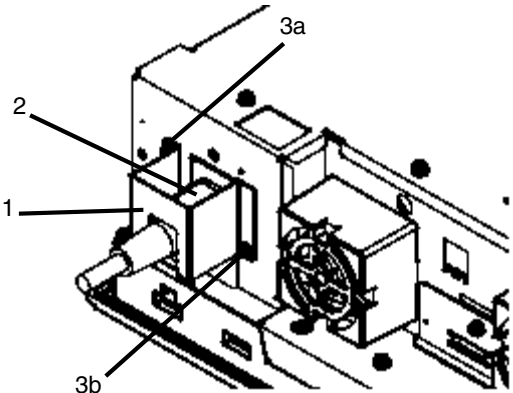

**Cord Clamp  
Description**

The table below present the description of the cord clamp

Number	Description
1	Cord Clamp
2	AC Plug
3a	Cord Clamp attachment screw
3b	Cord Clamp attachment screw

**Cable Retainer  
Bracket  
Mounting**

The chart below describes the cable retainer bracket installation:  
The picture below presents the cable retainer bracket mounting

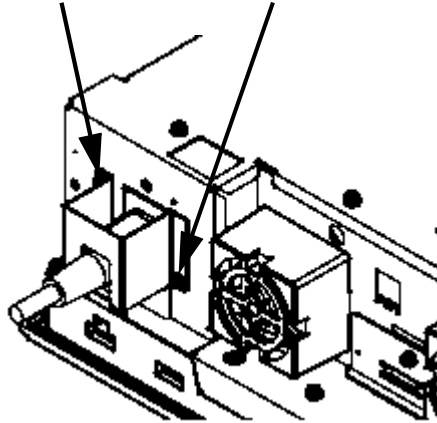

Description

step	Description
1	Unscrew the 2 screws shown by the arrows
2	Plug in the power cord
3	Position the retainer bracket and fasten by inserting the screws into the two holes indicated by arrows



## DC Version wiring

### Terminal Block Description

The figure below presents how to wire the Terminal Block

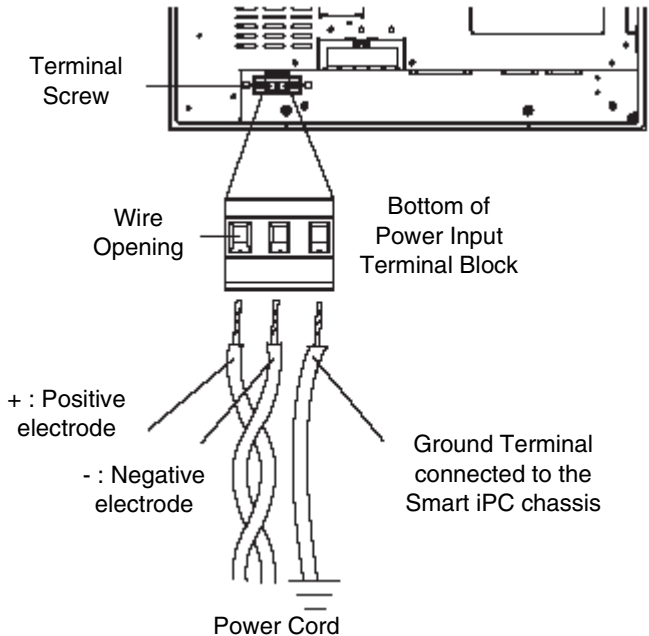

**Note :**

- The torque required to tighten these screw is 0.5 to 0.6N•m.
  - Do not solder the wire itself.
  - If the central wire's end strands are not twisted correctly, the end strands may either short against each other, or against an electrode.
  - **Protection fuse** : The 24 VDC mains supply modules for the Smart iPC are fitted with a protection fuse as standard. This fuse, fitted in series with the 24 V DC input, is located inside the module but cannot be accessed.
- When connecting the wires, be sure to follow the procedures given below.

### How to Wire the Terminal Block

Step	Action
1	Confirm that the power cable is disconnected from the power supply.
2	Loosen the screws from the middle three (3) terminals.
3	Remove the wire's external covering and insert the wire center stand into the opening.
4	Re-attach the screws.

**Possible connections**

**Connection of a DC 24 V Compact iPC supplied by a non-grounded safety DC network :**

The 0V and mechanical ground are connected internally.

Specific connection measures are to be taken for specific applications that use a floating network installation. These depending on the chosen mode of installation.

For this, the 24V DC input of the DC Compact iPC supply is isolated from the outputs and mechanical ground :

- Primary/Secondary dielectric strength: 1000V AC
- Primary/Ground dielectric strength: 1000V AC

**Connection of a 24V DC Compact iPC using a floating direct current network :**

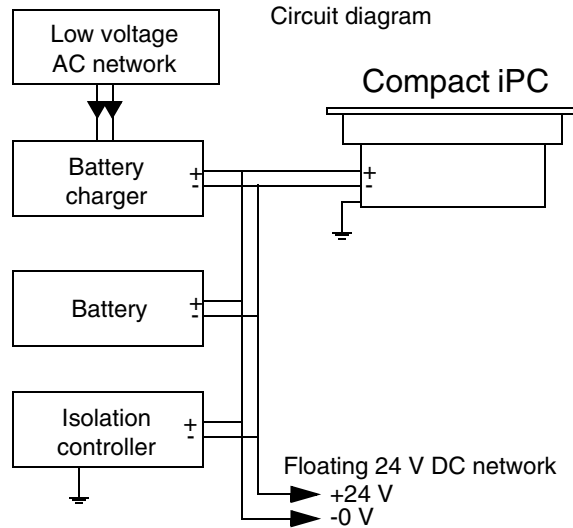

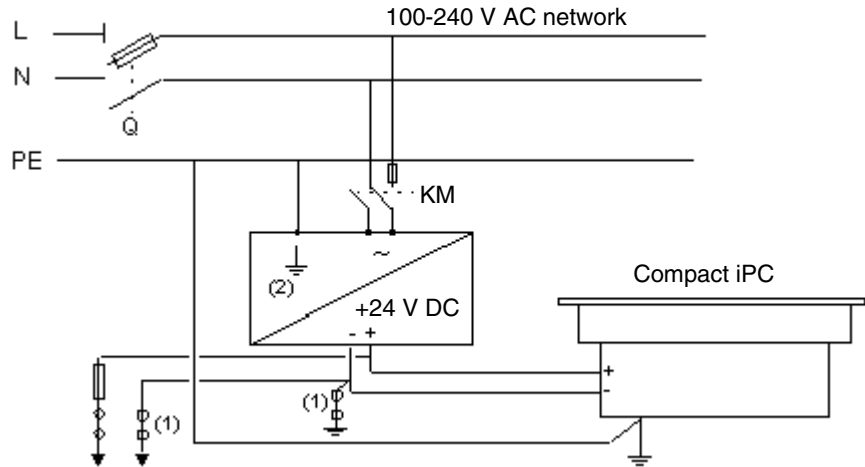
**Connection of a 24V DC Compact iPC using a ground referenced network :**

Q : General isolator

KM : Line contactor or circuit breaker

(1) : Isolation strip for detecting grounding faults

(2) : Possibility of using a TSX SUP 1101 process supply (see Schneider automation product catalog).

## Grounding Cautions

---

### Overview

**Note :** Use a grounding resistance of  $100\Omega$  or less, and a  $2\text{ mm}^2$  or thicker wire, or your country's applicable standard. For details, contact your local distributor.

---

### Dedicated Ground

- Set up a dedicated ground when using the rear panel's FG terminal.

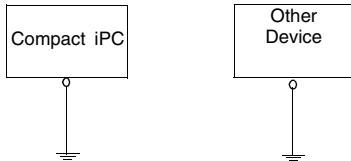

### Shared Ground allowed

- If a dedicated ground is not possible, use a shared ground, as shown in figure.
- Inside the Compact iPC unit, the SG (Signal Ground) and FG (Frame Ground) terminals are connected to each other.

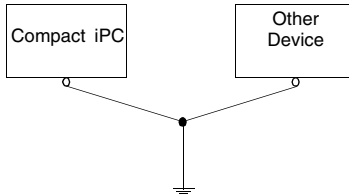

### Shared Ground not allowed

- When connecting an external device to Compact iPC with the SG terminal, ensure that no short-circuit loop is created when you set up the system.
- The grounding point must be as close to the Compact iPC as possible, and the grounding wires must be as short as possible. If the wires must be long, use thick, insulated wires and run them through conduits.

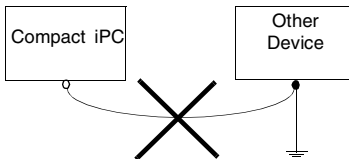

## Connecting I/O Signal Lines

---

### Precautions

- I/O signal lines must be wired separately from the power circuit cable. If the power circuit cable needs to be wired together with the input/output (I/O) signal lines for any reason, use shielded cables and ground one end of the shield to the Compact iPC's FG terminal.
-

## **Control drawing of the USB outlet on the Magelis iPC front panel**

---

### **Introduction**

The information below concerns the use of the USB outlet located on the front panels of the Magelis iPC used in Class 1, Division 2 Groups A, B, C, and D hazardous locations.

---

**Description**

Information taken from the Schneider Electric document: 35008871P07000.

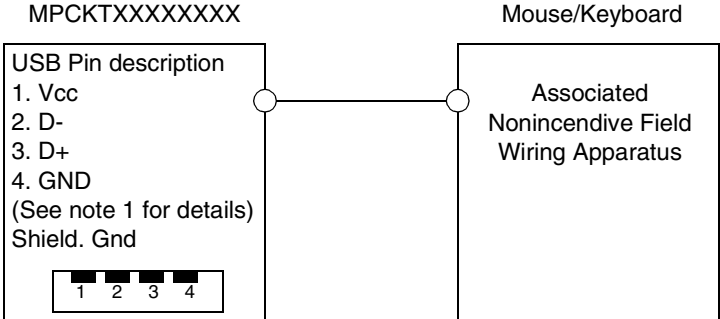

**Notes:**

1. Nonincendive Circuit Parameters:  
USB Port:

- Voc = 5.6 V
- Isc = 6.9 A
- Ca = 10  $\mu$ F
- La = 16  $\mu$ H

2. Selected Associated Nonincendive Field Wiring Apparatus shall satisfy the following:

Associated Nonincendive Field Wiring Apparatus (Mouse, Keyboard)		Industrial PC Model MPCKTXXXXXXX
Voc	≤	Vmax
Isc	≤	Imax
Ca	≥	Ci + C cable
La	≥	Li + L cable

3. If the electrical parameters of the cable are unknown, the following values may be used: Capacitance = 60pF/ft Inductive = 0.20  $\mu$ H/ft

4. Nonincendive Field Wiring must be installed in accordance with article 501.4(B)(3) of the National Electrical Code ANSI/NFPA 70.

5. Associated Nonincendive Field wiring Apparatus shall not contain or be connected to another source of power.





---

## Getting started

# 5

---

### First power-up

#### Warning

**Note:** Before the first power-up, please read the "LIMITED USE LICENSE AGREEMENT" carefully, then remove the seal.

#### Preparation

On first power-up, it is necessary, depending on the software configuration of your MPC••, to perform the following operations:

- You need to enter the licence number of the operating system. For this action, you need to connect a PS/2 or USB keyboard to the unit.
  - You need to customize and parameter your system or see Installation Guide for Magelis iPC industrial PC.
  - You have to install, customize and parameter of Schneider Automation and Schneider Electric applications (Unity Pro, PL7 Junior or PL7 Pro, Vijeo Look, OFS, MMI 17, XBT-L1000, PL7-07)
-

### Some useful tools

You can notice in the taskbar some useful shortcuts.

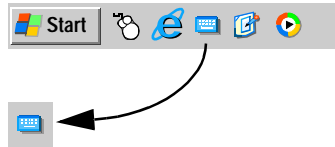

- This is the virtual keyboard. Just click on it, and a graphical keyboard appears. It is useful when you don't want or can't connect a keyboard to the unit.



- This is the virtual mouse button selector. It allows the user to associate the next "click" to a "right click". For instance, this tool permits the use of contextual menus.



Backlight  
Brightness

- Configuration Panel / Brightness : This link allows the user to change the brightness of the screen (useful for dark areas).

---

### CD restore

See Installation Guide for Magelis iPC industrial PC.

---

---

## Hardware extensions

# 6

---

### At a Glance

#### Subject of this chapter

This chapter concerns the hardware extensions for the Magelis Compact iPC. A wide variety of optional units, Main Memory, CF cards, PCMCIA (PC cards) manufactured by Schneider Electric and commercial expansion boards (PCI bus compatible board (1), PCMCIA (PC Cards) can be used with the Compact iPC. Unscrew the five (5) cover attachment screws, and remove the cover.

#### What's in this Chapter?

This chapter contains the following topics:

Topic	Page
Before installation	52
Removing the Compact iPC Unit's Cover	53
Compact 667 MHz iPC internal view	54
Compact P4 iPC Internal View	55
Main Memory Installation	57
Expansion Board (PCI) Installation	58
PCMCIA Unit Installation	60
CF Card Installation and Removal	62

---

## Before installation

---

### Overview

Install the desired products as shown in the "Compact iPC Internal View" drawing. For the detailed optional unit installation procedures, refer to that unit's "Installation Guide".

	<b>WARNING</b>
	<p><b>Be sure to disconnect the power cord from the power supply and confirm that power is not supplied to the Compact iPC unit before installing any optional units, Main Memory, CF cards, or expansion boards. Failure to do so can result in an electric shock. Important</b></p> <ul style="list-style-type: none"><li>● Use a screwdriver to loosen and tighten the screws. Be sure not to tighten the screws too tightly. Excessive force can damage the equipment.</li><li>● When removing or replacing screws, be careful that they do not fall inside the Compact unit's chassis.</li></ul> <p><b>Failure to follow this precaution can result in death, serious injury, or equipment damage.</b></p>

---

## Removing the Compact iPC Unit's Cover

### How to Remove the Compact iPC Unit's Cover

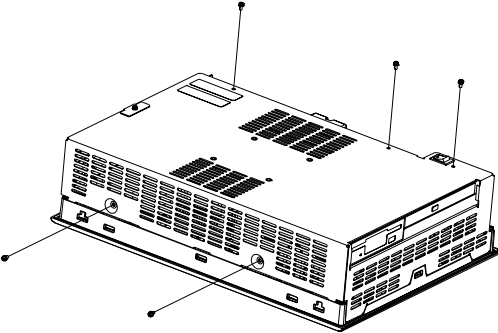
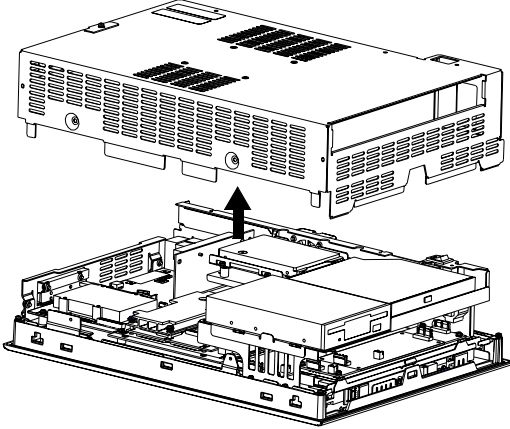
Step	Action
1	Lay the Compact iPC unit on its front face and remove the five (5) cover attachment screws 
2	Lay the Compact iPC unit on its front face and remove the five (5) cover attachment screws 

## Compact 667 MHz iPC internal view

### Illustration

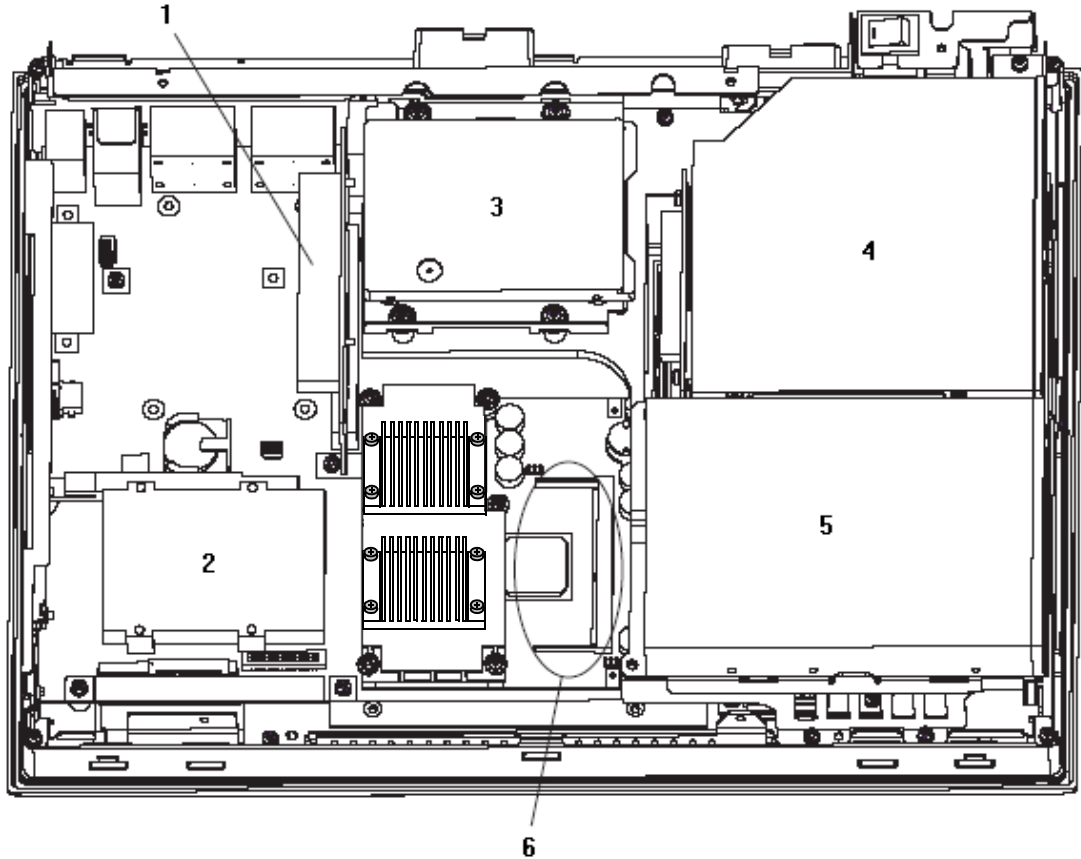

### Description

Number	Description
1	Expansion Board Interface (1 port)
2	PCMCIA Slot (2 ports)
3	HDD Unit
4	CD-ROM Drive
5	FDD Drive
6	Main Memory Installation Area (1 port)

### Compact P4 iPC Internal View

Illustration

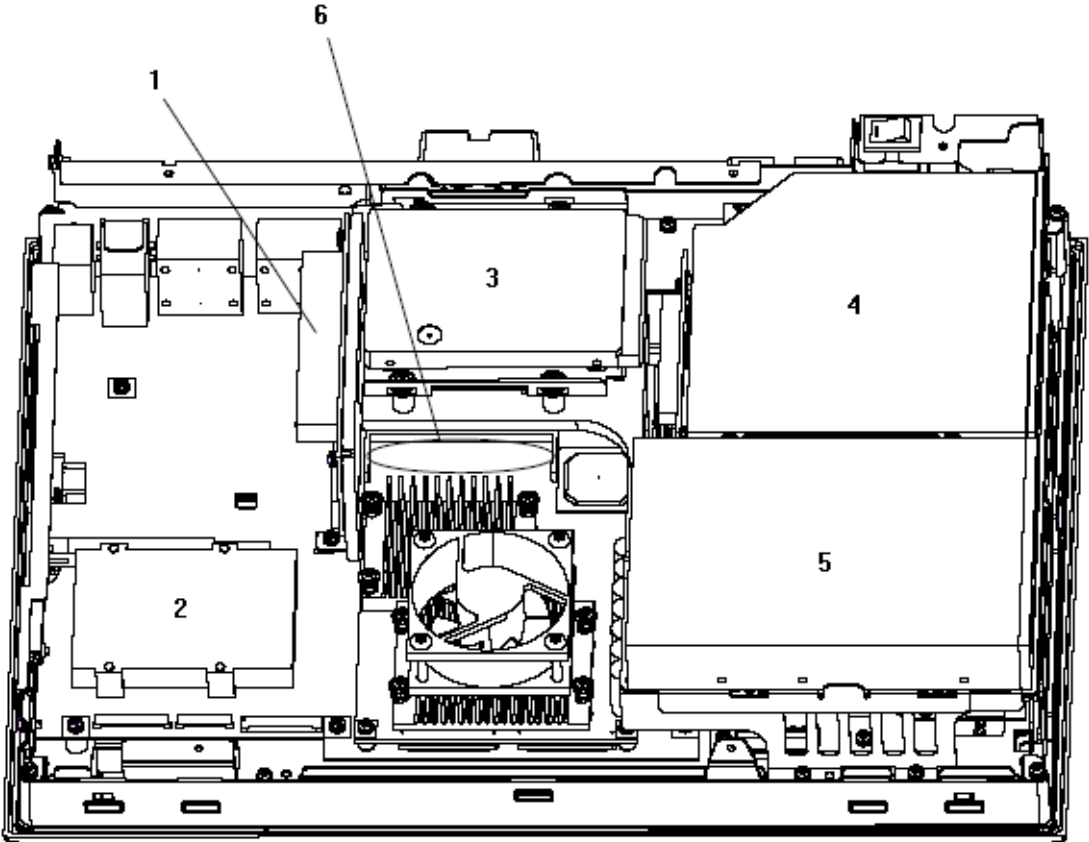

**Description**

<b>Number</b>	<b>Description</b>
1	Expansion Board Interface (1 port)
2	PCMCIA Slot (2 ports)
3	HDD Unit
4	CD-ROM Drive
5	FDD Drive
6	Main Memory Installation Area (1 port)

---



## Main Memory Installation

### Illustration

The figure below presents the description of the Main Memory connector

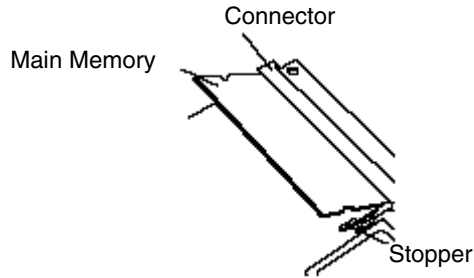

### How to Install the Main Memory

The table below presents the operating mode to install the Main Memory module

Step	Action
1	Remove the Compact iPC unit's rear cover
2	Angle the main memory (2a) module down slightly, and push it in until the connector pins mate with the module's pins. Then, lower the module until it is horizontal and insert it completely into the connector (2b). This connector is shown in Compact iPC Internal View.
3	Push in the main memory module (2a) until the stopper (3a) snaps into place.

## Expansion Board (PCI) Installation

### How to Install the Expansion Board

The table below presents the operating mode to install the Main Memory module.

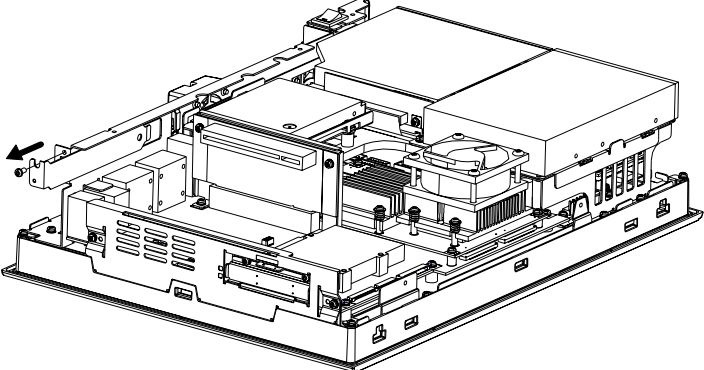
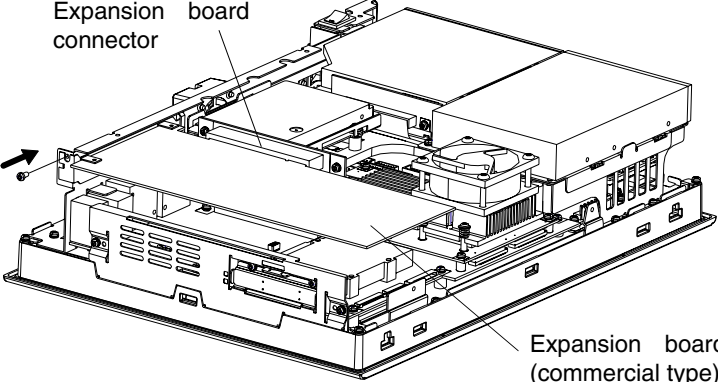
Step	Action
1	Remove the Compact iPC unit's rear cover see Removing the Compact iPC Unit's Cover
2	Remove the blank panel's screw, and detach the blank panel. 
3	Insert the expansion board (commercial-type PCI) into the expansion board connector, and secure it in place using the filler panel's screw. The necessary torque is 0.5N•m to 0.6N•m. Expansion board connector  Expansion board (commercial type)

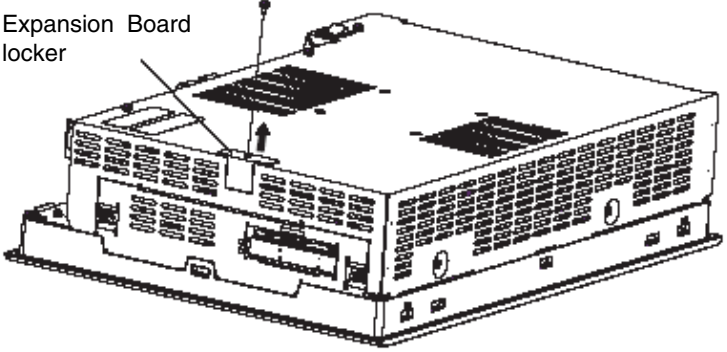
Step	Action
4	<p>Replace the rear cover and secure it in place using the five (5) attachment screws.</p> <p><b>Note :</b></p> <ul style="list-style-type: none"><li>• The maximum size allowed for an expansion board is 240mm [9.44in.] x 106.68mm [4.2in.]. When using an expansion board of this size, be sure to secure it in place using the expansion board support cover. Before the rear cover is closed, as explained in step (4) above, remove the expansion board support cover screw and be sure the expansion board support cover is detached. Next, replace the rear cover, and then secure the expansion board support cover to the rear cover using the expansion board locker system. The necessary torque is 0.5N•m to 0.6N•m.</li></ul> <p>Expansion Board locker</p> 

## PCMCIA Unit Installation

### How to Install the PCMCIA Unit

The table below presents the operating mode to install the PCMCIA Unit

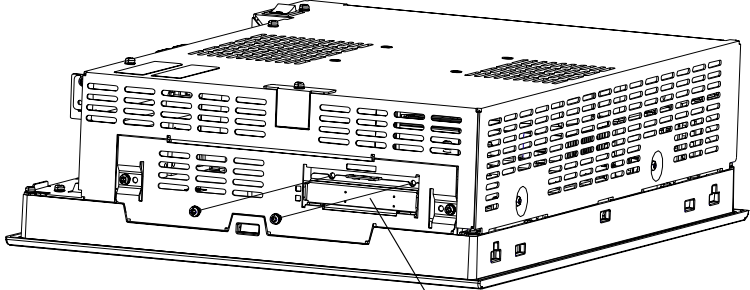
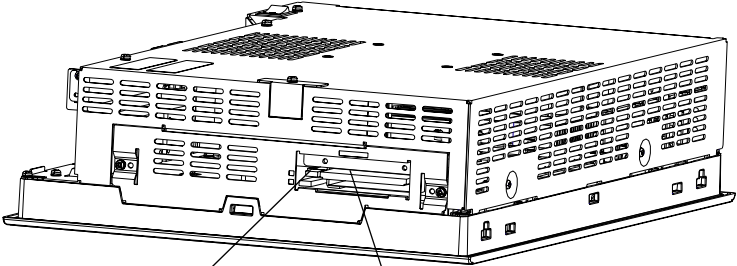
Step	Action
1	Remove the Compact iPC unit's rear cover see Removing the Compact iPC Unit's Cover
2	Remove the PCMCIA slot cover's screws.   <p style="text-align: center;">PCMCIA Slot Cover</p>
3	<p><b>Inserting a commercial-type PC Card</b> Insert the commercial-type PC Card into the PCMCIA connector.</p>  <p style="text-align: center;">Eject Button      PC Card (commercial)</p> <p><b>Note :</b></p> <ul style="list-style-type: none"> <li>• The PCMCIA slot has 2 connectors. When inserting the PCMCIA Card, check carefully that it is connected to the correct connector.</li> </ul> <p><b>Removing the PC Card</b> Press the eject button twice to remove the PC Card from the PCMCIA connector. Pressing the eject button once causes its tip to come out. Pressing the eject button the second ejects the PC Card from the PCMCIA slot.</p>

---

<b>Step</b>	<b>Action</b>
4	<p>Replace the PCMCIA slot cover removed in (1) and secure it in place using the two PCMCIA slot screws. The necessary torque is 0.5N•m to 0.6N•m.</p> <p><b>Note :</b></p> <ul style="list-style-type: none"><li>• When using a PC Card with a cable attached, Schneider recommends you use a clamp or other type of device to prevent vibration from possibly dislodging the cable.</li><li>• Be sure to stop the Compact iPC unit PC Card's driver prior to removing the PC Card. A failure to stop this driver may result in damage to either the PC Card, the PC Card's data, or may cause Windows. to hang up. For information on the procedure for stopping the PC Card's driver, please refer to your OS' User Manual.</li></ul>

---

## CF Card Installation and Removal

---

### When using the Unit and a CF Card

	<b>CAUTION</b>
	<p>Be sure to use only CF Cards manufactured by Schneider. Compact iPC unit performance cannot be guaranteed when using another manufacturer's CF Card.</p> <p>Be sure to follow the instructions given below to prevent the CF Card's internal data from being destroyed or a CF Card malfunction from occurring:</p> <ul style="list-style-type: none"><li>• DO NOT bend the CF Card.</li><li>• DO NOT drop or strike the CF Card against another object.</li><li>• Keep the CF Card dry.</li><li>• DO NOT touch the CF Card connectors.</li><li>• DO NOT disassemble or modify the CF Card.</li></ul> <p><b>Failure to follow this precaution can result in injury or equipment damage.</b></p>

**When using the  
CF Card Unit and  
the CF Card**

	<p><b>CAUTION</b></p>
	<p><b>Follow the precautions below</b></p> <p>Prior to inserting the CF Card, be sure to confirm that the rear and the front of the CF Card are correctly oriented, and that the CF Card connector position is correct. If the CF Card is inserted incorrectly, the CF Card, its internal data, and the CF card unit may be damaged.</p> <p>Since the Compact iPC unit's OS views the CF Card as a hard disk, do not remove or insert the CF Card when the unit's power is switched ON. Doing so may damage data and stop OS operation. Be sure to shut down the OS and switch power OFF prior to removing or inserting a CF Card.</p> <p>Never turn OFF or reset the Compact iPC while accessing the CF Card to prevent damaging file data. Also, be sure to shut down the Compact iPC unit's OS before turning OFF the main power.</p> <p><b>Failure to follow this precaution can result in injury or equipment damage.</b></p>

**Limitation of the  
number of  
writings of data**

The CF Card has a limitation of the number of writings of data of approximately 100,000 times. Therefore, be sure to back up all CF Card data regularly to another storage media.

**CF Card  
Insertion and  
Removal**

Familiarize yourself with the differences between the top and bottom surfaces of the CF Card. Also, be sure that the Card is properly oriented when it is inserted (i.e. whether the top of the card is up or down etc.).

### How to Insert the CF Card

The table below presents the operating mode to insert the CF Card.

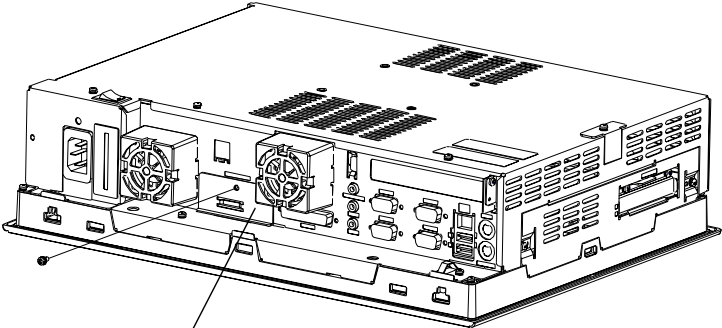
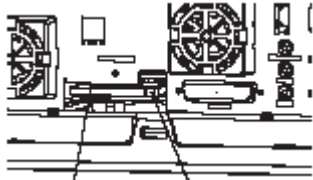
Step	Action
1	<p>Unscrew the CF Card cover's attachment screw (1), and remove the CF Card cover..</p>  <p style="text-align: center;">CF Card Cover</p>
2	<p>Insert the CF Card firmly into the CF card slot, and check that the eject button pops out..</p>  <p style="text-align: center;">CF Card      Eject Button</p>

### How to Remove the CF Card

The table below presents the operating mode to remove the CF Card.

Step	Action
1	Press the eject button in fully to remove the CF Card from the CF Card slot.
2	<p>After inserting/removing the CF card, be sure to replace the CF Card cover and secure it in place using the attachment screw.</p> <p><b>Important :</b></p> <ul style="list-style-type: none"> <li>• The necessary torque is 0.5N•m to 0.6N•m.</li> </ul>



---

# Configuration of the Bios



---

## At a Glance

### Subject of this chapter

This chapter describes how to access certain parameters of the Bios (operating system of the computer) that need to be modified depending on its existing configuration.

### What's in this Chapter?

This chapter contains the following topics:

Topic	Page
Accessing the Bios configuration of the Compact 667 MHz iPC	66
Standard CMOS Features for the Compact 667 MHz iPC	67
Accessing the Bios configuration of the Pentium 4 iPC	69
Standard CMOS Features for the Pentium 4 iPC	70

---

## Accessing the Bios configuration of the Compact 667 MHz iPC

### Precautions

#### Important :

- Normally, use only the factory (default) settings.

#### Note :

- The following settings are those pre-set at the factory.

### How to access the Bios Configuration

The table below presents the operating mode to access the Bios Configuration.

Step	Action		
1	Connect a keyboard to the Compact 667 MHz iPC Unit.		
2	Turn the main power ON.		
3	<p>After the message "Press &lt;DEL&gt; to Enter SETUP" appears, press the [DEL] key until the following screen appears.</p> <div style="border: 1px solid black; padding: 10px; margin: 10px 0;"> <p style="text-align: center;">Phoenix FirstBIOS(tm) Desktop CMOS Setup Utility</p> <table border="1" style="width: 100%; border-collapse: collapse;"> <tr> <td style="width: 50%; vertical-align: top;"> <ul style="list-style-type: none"> <li>▸ Standard CMOS Features</li> <li>▸ Advanced BIOS Features</li> <li>▸ Advanced Chipset Features</li> <li>▸ Integrated Peripherals</li> <li>▸ Power Management Setup</li> <li>▸ PnP/PCI Configurations</li> <li>▸ System Monitor Setup</li> </ul> </td> <td style="width: 50%; vertical-align: top;"> <ul style="list-style-type: none"> <li>▸ Frequency/Voltage Control</li> <li>Load Fail-Safe Defaults</li> <li>Load Optimized Defaults</li> <li>Set Supervisor Password</li> <li>Set User Password</li> <li>Save &amp; Exit Setup</li> <li>Exit Without Saving</li> </ul> </td> </tr> </table> <p>ESC : Quit    F9 : Menu in BIOS    up down right left : Select Item F10 : Save &amp; Exit Setup</p> <p style="text-align: center;">Time, Date, Hard Disk Type...</p> <p>KEYBOARD ACTION KEYS Provides a summary of the keyboard keys used to carry out the set up.</p> <p>SYSTEM SETTING SELECTION AREA Each of the titles (areas) listed here contains system setting items.</p> </div>	<ul style="list-style-type: none"> <li>▸ Standard CMOS Features</li> <li>▸ Advanced BIOS Features</li> <li>▸ Advanced Chipset Features</li> <li>▸ Integrated Peripherals</li> <li>▸ Power Management Setup</li> <li>▸ PnP/PCI Configurations</li> <li>▸ System Monitor Setup</li> </ul>	<ul style="list-style-type: none"> <li>▸ Frequency/Voltage Control</li> <li>Load Fail-Safe Defaults</li> <li>Load Optimized Defaults</li> <li>Set Supervisor Password</li> <li>Set User Password</li> <li>Save &amp; Exit Setup</li> <li>Exit Without Saving</li> </ul>
<ul style="list-style-type: none"> <li>▸ Standard CMOS Features</li> <li>▸ Advanced BIOS Features</li> <li>▸ Advanced Chipset Features</li> <li>▸ Integrated Peripherals</li> <li>▸ Power Management Setup</li> <li>▸ PnP/PCI Configurations</li> <li>▸ System Monitor Setup</li> </ul>	<ul style="list-style-type: none"> <li>▸ Frequency/Voltage Control</li> <li>Load Fail-Safe Defaults</li> <li>Load Optimized Defaults</li> <li>Set Supervisor Password</li> <li>Set User Password</li> <li>Save &amp; Exit Setup</li> <li>Exit Without Saving</li> </ul>		
4	Use the arrow keys to move the cursor to the desired selection.		

## Standard CMOS Features for the Compact 667 MHz iPC

### Precaution

#### Important :

- Normally, use only the factory (default) settings.

### Standard CMOS Features

Selecting the STANDARD CMOS FEATURES menu item produces the following screen.

Phoenix FirstBIOS(tm) Desktop CMOS Setup Utility Standard CMOS Features		
Date (mm:dd:yy): Time (hh:mm:ss):	Wed, Jun 25 2003 14 : 50 : 3	Item Help
▶ IDE Primary Master ▶ IDE Primary Slave ▶ IDE Secondary Master ▶ IDE Secondary Slave	[None] [None] [None] [None]	Menu Level ▶ Change the day, month, year and century
Drive A	[1.44M, 3.5 in.]	
Video	[EGA/VGA]	
Halt On	[All, But Keyboard]	
Base Memory	640K	
Extended Memory	244736K	
Total Memory	245760K	
up/down/right/left:Move Enter:Select +/-/PU/PD:Value F10:Save ESC:Exit F1: General Help F5:Previous Values F6:Fail-Safe Defaults F7:Optimized Defaults		

### How to Modify the Date

#### Date (mm:dd:yy)

The Compact iPC unit's internal calendar and clock allow you to set the date. The day of the week is automatically set.

Month: Jan/Feb/Mar/Apr/May/June/Jul/Aug/Sep/Oct/Nov/Dec

Day:1 to 31

Year: 1999 to 2099

**How to Modify the Time**

**Time (hh:mm:ss)**

The Compact iPC unit's internal clock can be set. The hh/mm/ss (0:0:0) format is factory set prior to shipping.

Hours: 0 to 23

Minutes: 0 to 59

Seconds: 0 to 59

---

**How to Set Supervisor Password**

This password is used to change system information settings. It is designed to prevent unapproved users from changing the system information settings. Entering up to 8 characters here will overwrite the current password.

When you wish to have no password, click on the [Enter] key. Next, the words "PASSWORD DISABLE" will appear, providing confirmation that the Password is no longer set.

When password input is required, use the [Advanced BIOS Features] area's [Security Option] feature to enter the password.

**See :** Advanced BIOS Features

---

**How to Set User Password**

This password is used to view system information settings. It is designed to prevent unapproved users from viewing the system information settings. Entering up to 8 characters here will overwrite the current password.

When you wish to have no password, click on the [Enter] key. Next, the words "PASSWORD DISABLE" will appear, providing confirmation that the Password is no longer set.

When password input is required, use the [Advanced BIOS Features] area's [Security Option] feature to enter the password.

**See :** Advanced BIOS Features

**Important :**

- When using either [Set Supervisor Password] or [Set User Password], you can easily view and change system settings.
  - When using BOTH the [Set Supervisor Password] and [Set User Password] features, [Set User Password] will allow you to only view system data, not change it.
- 

**How to Save and Exit Setup**

This feature saves the settings entered in the Setup Utility and restarts the Compact iPC unit.

---

**How to Exit Without Saving**

This feature quits the Setup Utility program without saving any settings entered.

---

## Accessing the Bios configuration of the Pentium 4 iPC

### Precautions

#### Important :

- Normally, use only the factory (default) settings.

#### Note :

- The following settings are those pre-set at the factory.

### How to Access the Bios Configuration

The table below presents the operating mode to access the Bios Configuration.

Step	Action		
1	Connect a keyboard to the Pentium 4 iPC Unit.		
2	Turn the main power ON.		
3	<p>After the message "Press &lt;DEL&gt; to Enter SETUP" appears, press the [DEL] key until the following screen appears.</p> <div style="border: 1px solid black; padding: 10px; margin: 10px 0;"> <p style="text-align: center;">Phoenix FirstBIOS(tm) Desktop CMOS Setup Utility</p> <table border="1" style="width: 100%; border-collapse: collapse;"> <tr> <td style="width: 50%; vertical-align: top;"> <ul style="list-style-type: none"> <li>▶ Standard CMOS Features</li> <li>▶ Advanced BIOS Features</li> <li>▶ Advanced Chipset Features</li> <li>▶ Integrated Peripherals</li> <li>▶ Power Management Setup</li> <li>▶ PnP/PCI Configurations</li> <li>▶ System Monitor Setup</li> </ul> </td> <td style="width: 50%; vertical-align: top;"> <ul style="list-style-type: none"> <li>▶ Frequency/Voltage Control</li> <li>Load Fail-Safe Defaults</li> <li>Load Optimized Defaults</li> <li>Set Supervisor Password</li> <li>Set User Password</li> <li>Save &amp; Exit Setup</li> <li>Exit Without Saving</li> </ul> </td> </tr> </table> <p>ESC : Quit    F9 : Menu in BIOS    up down right left : Select Item F10 : Save &amp; Exit Setup</p> <p style="text-align: center;">Time, Date, Hard Disk Type...</p> <p><b>KEYBOARD ACTION KEYS</b> Provides a summary of the keyboard keys used to carry out the set up.</p> <p><b>SYSTEM SETTING SELECTION AREA</b> Each of the titles (areas) listed here contains system setting items.</p> </div>	<ul style="list-style-type: none"> <li>▶ Standard CMOS Features</li> <li>▶ Advanced BIOS Features</li> <li>▶ Advanced Chipset Features</li> <li>▶ Integrated Peripherals</li> <li>▶ Power Management Setup</li> <li>▶ PnP/PCI Configurations</li> <li>▶ System Monitor Setup</li> </ul>	<ul style="list-style-type: none"> <li>▶ Frequency/Voltage Control</li> <li>Load Fail-Safe Defaults</li> <li>Load Optimized Defaults</li> <li>Set Supervisor Password</li> <li>Set User Password</li> <li>Save &amp; Exit Setup</li> <li>Exit Without Saving</li> </ul>
<ul style="list-style-type: none"> <li>▶ Standard CMOS Features</li> <li>▶ Advanced BIOS Features</li> <li>▶ Advanced Chipset Features</li> <li>▶ Integrated Peripherals</li> <li>▶ Power Management Setup</li> <li>▶ PnP/PCI Configurations</li> <li>▶ System Monitor Setup</li> </ul>	<ul style="list-style-type: none"> <li>▶ Frequency/Voltage Control</li> <li>Load Fail-Safe Defaults</li> <li>Load Optimized Defaults</li> <li>Set Supervisor Password</li> <li>Set User Password</li> <li>Save &amp; Exit Setup</li> <li>Exit Without Saving</li> </ul>		
4	Use the arrow keys to move the cursor to the desired selection.		

## Standard CMOS Features for the Pentium 4 iPC

---

### Precaution

#### Important :

- Normally, use only the factory (default) settings.
- 

### Standard CMOS Features

Selecting the STANDARD CMOS FEATURES menu item produces the following screen.

Phoenix FirstBIOS(tm) Desktop CMOS Setup Utility Standard CMOS Features		
Date (mm:dd:yy): Time (hh:mm:ss):	Wed,Jun 25 2003 14 : 50 : 3	Item Help
<input type="checkbox"/> ▶ IDE Primary Master <input type="checkbox"/> ▶ IDE Primary Slave <input type="checkbox"/> ▶ IDE Secondary Master <input type="checkbox"/> ▶ IDE Secondary Slave	[None] [None] [None] [None]	Menu Level ▶ Change the day, month, year and century
Drive A Drive B	[1.44M, 3.5 in.] [None]	
Video Halt On	[EGA/VGA] [All,But Keyboard]	
Base Memory Extended Memory Total Memory	640K 251904K 252928K	
up/down/right/left:Move Enter:Select +/-/PU/PD:Value F10:Save ESC:Exit F1: General Help F5:Previous Values F6:Fail-Safe Defaults F7:Optimized Defaults		

### How to Modify the Date

#### Date (mm:dd:yy)

The Compact iPC unit's internal calendar and clock allow you to set the date. The day of the week is automatically set.

Month: Jan/Feb/Mar/Apr/May/June/Jul/Aug/Sep/Oct/Nov/Dec

Day:1 to 31

Year: 1999 to 2099

---

**How to Modify  
the Time****Time (hh:mm:ss)**

The Compact iPC unit's internal clock can be set. The hh/mm/ss (0:0:0) format is factory set prior to shipping.

Hours: 0 to 23

Minutes: 0 to 59

Seconds: 0 to 59

---

**How to Set  
Supervisor  
Password**

This password is used to change system information settings. It is designed to prevent unapproved users from changing the system information settings. Entering up to 8 characters here will overwrite the current password.

When you wish to have no password, click on the [Enter] key. Next, the words "PASSWORD DISABLE" will appear, providing confirmation that the Password is no longer set.

When password input is required, use the [Advanced BIOS Features] area's [Security Option] feature to enter the password.

**See :** Advanced BIOS Features

---

**How to Set User  
Password**

This password is used to view system information settings. It is designed to prevent unapproved users from viewing the system information settings. Entering up to 8 characters here will overwrite the current password.

When you wish to have no password, click on the [Enter] key. Next, the words "PASSWORD DISABLE" will appear, providing confirmation that the Password is no longer set.

When password input is required, use the [Advanced BIOS Features] area's [Security Option] feature to enter the password.

**See :** Advanced BIOS Features

**Important :**

- When using either [Set Supervisor Password] or [Set User Password], you can easily view and change system settings.
  - When using BOTH the [Set Supervisor Password] and [Set User Password] features, [Set User Password] will allow you to only view system data, not change it.
- 

**How to Save and  
Exit Setup**

This feature saves the settings entered in the Setup Utility and restarts the Compact iPC unit.

---

**How to Exit  
Without Saving**

This feature quits the Setup Utility program without saving any settings entered.

---





---

# Maintenance



# 8

---

## At a Glance

### Subject of this chapter

This chapter covers maintenance of the computers from the Magelis iPC range.

### What's in this Chapter?

This chapter contains the following topics:

Topic	Page
Reinstallation	74
Cleaning	75

## Reinstallation

---

### At a Glance

In certain cases, it may be necessary to reinstall the operating system. The reinstallation procedure is given below.

---

### Before reinstalling

Before reinstalling the operating system, make sure that the following equipment is at hand:

- The restore CD-ROM that was provided with the product
- The recovery disk
- A PS/2 or USB keyboard

**Note:** save all important data contained on the hard drive (the reinstallation process erases all data on the hard drive). The reinstallation process will return the computer to its factory settings.

---

### Reinstallation

Proceed as follows

Step	Action
1	Insert the recovery disk in the disk drive and power-up the computer.
2	Insert the restore CD-ROM in the CD-ROM drive.
3	Follow the messages that appear on the screen.
4	Once installation is complete, remove the disk and the CD-ROM from their drives and restart the computer.

---

### Specific drivers

Specific drivers are available on the reinstallation CD-ROM. These drivers are already installed on your machine and should not need to be reinstalled.



---

## Cleaning

### Precaution

	<b>CAUTION</b>
	<p><b>Do not clean the unit with thinner, organic solvents, or strong acids.</b></p> <p><b>Failure to follow this precaution can result in injury or equipment damage.</b></p>

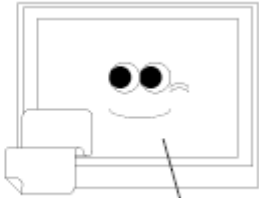
### How to Clean the Display

Action	Figure
<p>When the display surface or frame become dirty, use a soft cloth moistened with neutral detergent to wipe away any dust or stains.</p>	<div style="display: flex; justify-content: space-around; align-items: center;"> <div style="text-align: center;">  <p>Neutral detergent</p> </div> <div style="text-align: center;">  <p>Display</p> </div> </div>
<p>Do not use sharp or hard objects, such as a mechanical pencil or screwdriver, to push on the display. This could damage the unit.</p>	

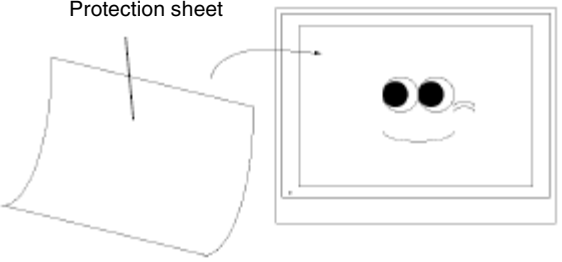
Action	Figure
<p>Use the screen protection sheet when using the Compact iPC in extremely dirty or dusty areas.</p>	

**How to Install Gasket Replacement**

The moisture resistant gasket protects the Compact iPC and improves its water resistance. See Installation Procedures for instructions on installing the Compact iPC's gasket.  
 Refer to Hardware Installation Procedures chapter

**Important :**

- A gasket which has been used for a long period of time may have scratches or dirt on it, and could have lost much of its water resistance. Be sure to change the gasket periodically (or when scratches or dirt become visible).

**How to Clean the Fan Fiter**

Since excessive dirt and dust in the filter of the Compact iPC's electric fan can potentially affect the performance of the unit, regular inspection and cleaning of the filter is strongly recommended.

## Illustration

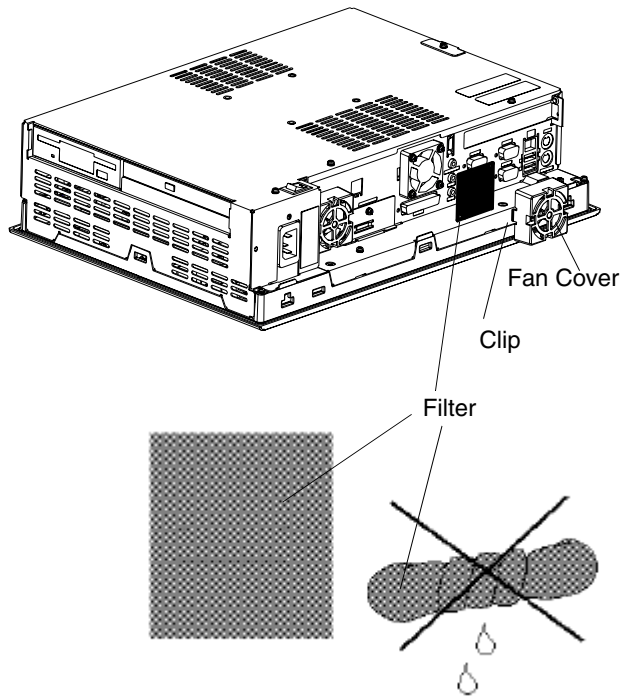

The table below presents the operating mode to clean the Fan Filter.

Step	Action
1	Remove the fan cover with nipping the both clips of the fan cover.
2	Remove the filter from the fan cover.
3	<p>Clean the filter completely. If stubborn dirt or stains are present, wash the filter with a neutral detergent.</p> <p><b>Important :</b></p> <ul style="list-style-type: none"> <li>• Do not wring the filter to dry it.</li> <li>• When drying the filter, dry it without exposing it to direct sunlight.</li> <li>• Allow it to air dry completely before reattaching to the Compact iPC.</li> </ul>
4	After fixing the filter to the filter cover, reattach the fan cover .



---

# Installation

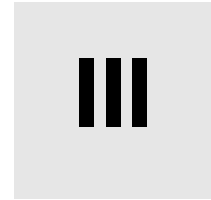

---

## At a Glance

### Subject of this part

This part concerns product installation.

### What's in this Part?

This part contains the following chapters:

Chapter	Chapter Name	Page
9	Dimension/Assembly	81
10	Connections to PLCs	93





---

## Dimension/Assembly



# 9

---

### At a Glance

#### Subject of this chapter

This chapter concerns the dimensions and the panel mouting of products.

#### What's in this Chapter?

This chapter contains the following topics:

Topic	Page
Dimensions	82
Cropping for Cabinet Installation	84
Panel Mounting	85
Installing the Compact iPC Unit	86

---

## Dimensions

---

### Dimensions of the Compact iPC Unit

The figure below presents the dimensions of the Compact iPC Unit.

Unit : mm[in]

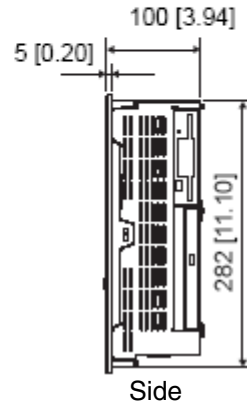
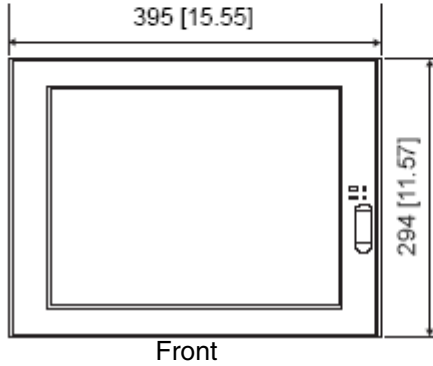
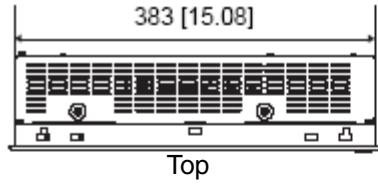

**Other  
Dimensions  
(with Installation  
Fasteners  
installed)**

The figure below presents the dimensions of the Compact iPC Unit with Installation Fasteners installed.

Unit : mm[in]

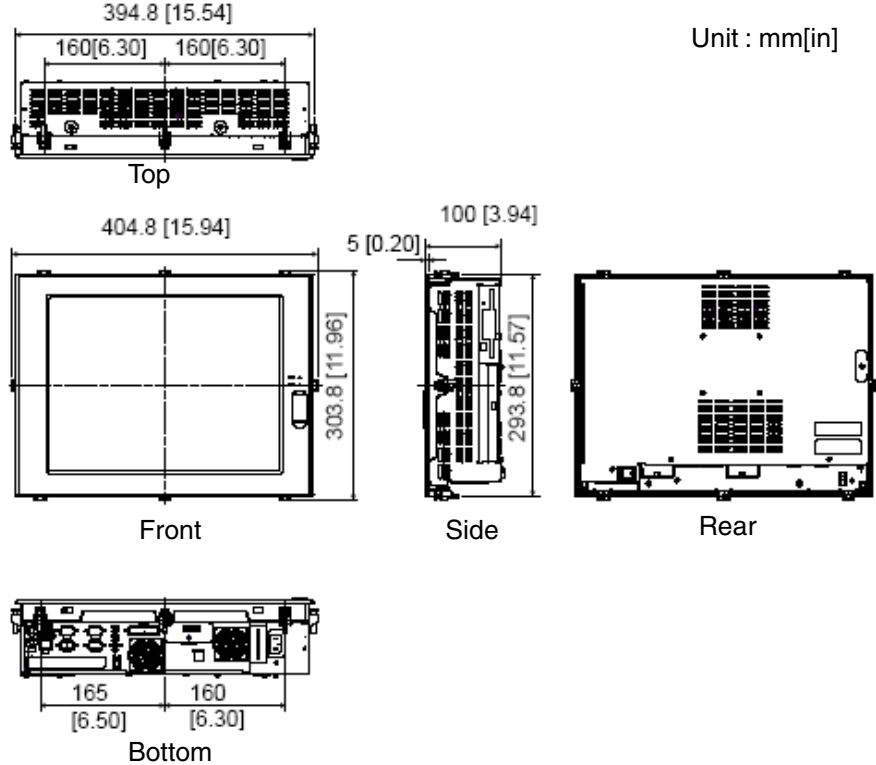

## Cropping for Cabinet Installation

---

### Overview

For cabinet installation, it is necessary for products to be cropped.

---

### Dimensions

The dimensions of the crop are given below.

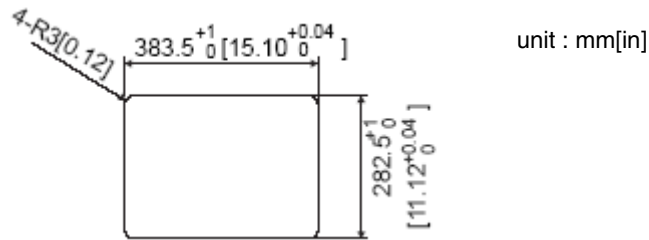

### Precautions

#### Important :

- Be sure the thickness of the installation panel is from 1.6 mm [0.06 in] to 10 mm [0.39 in] .
  - All panel surfaces used should be strengthened. Especially, if high levels of vibration are expected and the products installation surface (i.e. an operation panel's door, etc.) can move (i.e.open or close) due consideration should be given to the products weight.
  - To insure that the product's water resistance is maintained, be sure to install it into a panel that is flat and free of scratches or dents.
  - Be sure all installation tolerances are maintained to prevent the unit from falling out of its installation panel.
-

## Panel Mounting

### Overview

The products are designed to be attached to the door of a cabinet with the attachments described below

### Dimensions

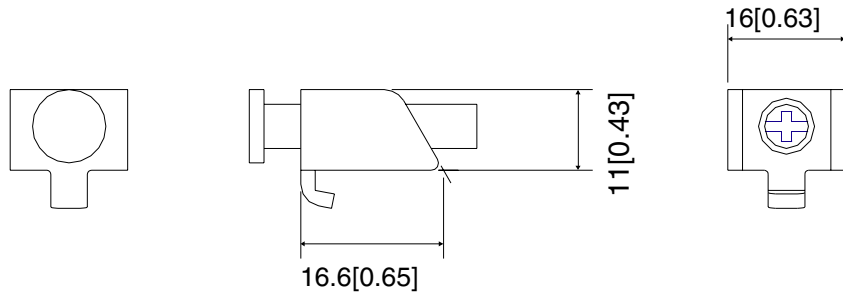

unit : mm[in]

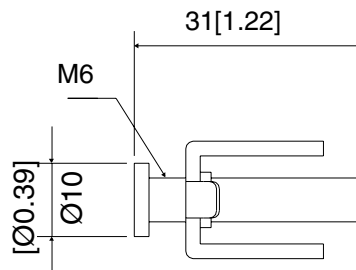

## Installing the Compact iPC Unit

---

### Installation Location

- Avoid placing the Compact iPC next to other devices that might cause overheating.
  - Keep the Compact iPC away from arc-generating devices such as magnetic switches and non-fuse breakers.
  - Avoid using the Compact iPC in environments where corrosive gases are present.
  - To ensure the reliability, operability and ventilation of the Compact iPC, be sure to install it in locations that are more than 50mm away from adjacent structures or equipment. Also, consider the need for installing or removing expansion boards, or connectors when designing and installing your product.
- 

### Illustration

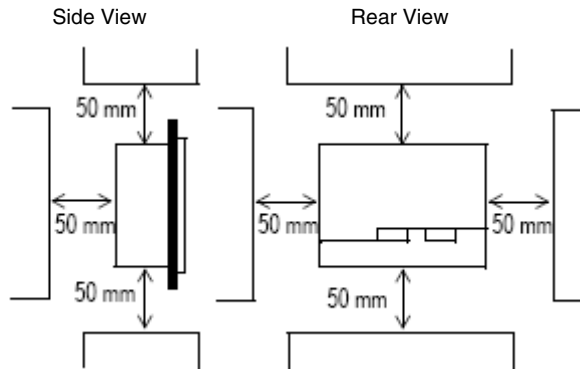

### Vibration and Shocks

If the Compact iPC is moved when its enclosure doors are open, or while it is installed in a rack equipped with caster wheels, or when using a stand with an arm attached or when attached to a wall, the hard disk can receive excessive vibration or jolting. Be especially careful at this time.

#### Important :

- Be sure not to move the Compact iPC unit while the HDD is starting up. This can lead to a machine breakdown (Even a slight movement of the unit should not be performed).
  - When using a fan to cool the Compact iPC unit, be sure that the fan does not point directly at any of the product's disk drive units.
-

**Illustration**

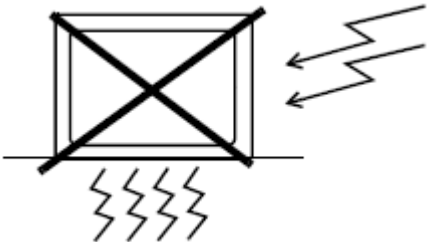

## How to Install the Compact iPC Unit

Follow the steps given below when installing the Compact iPC.

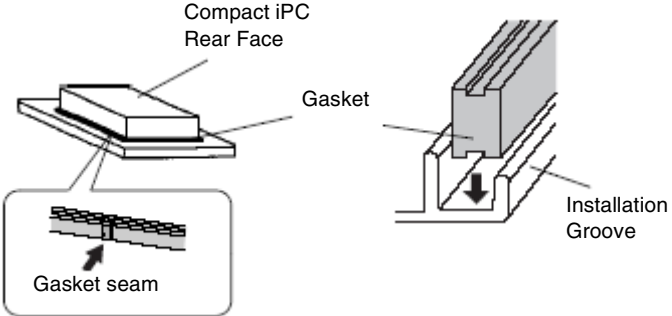
Step	Action
1	<p><b>Attaching the Installation Gasket</b></p> <p>Even if the your Compact iPC's Installation Gasket is not needed to prevent water from entering the unit, the gasket also acts as a vibration absorber and should always be attached. To install it, place the unit face down on a soft surface and attach the gasket to the rear side of the display face, in the plastic bezel's groove (see picture below).</p> <p><b>Important :</b></p> <ul style="list-style-type: none"> <li>• Before mounting the Compact iPC into a cabinet or panel, check that the installation gasket is attached to the unit.</li> <li>• A gasket which has been used for a long period of time may be scratched or dirty, and may have lost much of its water resistance. Be sure to change the gasket at least once a year, or when scratches or dirt become visible.</li> <li>• The corresponding gasket is provided into the maintenance kit ref.: MPC YK 50 MNT KIT.</li> <li>• Since the gasket is flexible but not elastic, be careful not to stretch it unnecessarily, as doing so could tear the gasket.</li> <li>• Be sure, when pushing the gasket into the installation groove and around the corners of the unit, that the gasket's seam is not placed in a corner. Placing the seam here could eventually cause the gasket to tear.</li> <li>• Be sure to place the gasket's flat, non-grooved side facing down.</li> </ul> <div style="text-align: center;">  </div> <p><b>Important :</b></p> <ul style="list-style-type: none"> <li>• If the installation gasket is not properly inserted into the groove, the gasket's moisture resistance may not be equivalent to IP65.</li> <li>• When the installation gasket is properly inserted, approximately 2.0 mm of it will extend outside the groove. Before installing a Compact iPC into a panel, be sure to confirm that the gasket is correctly in place.</li> </ul>

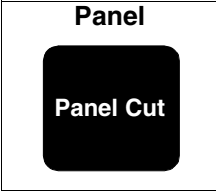
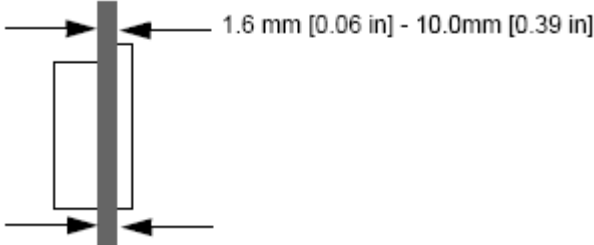

Step	Action
2	<p data-bbox="428 203 620 224"><b>Create a Panel Cut</b></p> <p data-bbox="428 230 1156 311">Create a panel cut for the Compact iPC, like that pictured here. Two additional items, the installation gasket and the installation fasteners are required when installing the unit.</p> <p data-bbox="428 318 686 339">See Panel Cut Dimensions</p> <div data-bbox="463 391 679 581" style="text-align: center;"><p data-bbox="536 396 606 417"><b>Panel</b></p></div> <p data-bbox="428 602 488 623"><b>Note :</b></p> <ul data-bbox="428 630 1156 711" style="list-style-type: none"><li data-bbox="428 630 1156 678">• To obtain the maximum degree of moisture resistance, be sure to install the Compact iPC on a smooth, flat surface.</li><li data-bbox="428 685 1156 711">• The panel itself can be from 1.6 mm [0.06 in] to 10.0 mm [0.39 in] thick</li></ul> <p data-bbox="428 717 1156 766"><b>Important :</b> Strengthening may be required for the panel. Be sure to consider the weight of the Unit when designing the panel.</p> <div data-bbox="445 812 1039 1055" style="text-align: center;"></div>

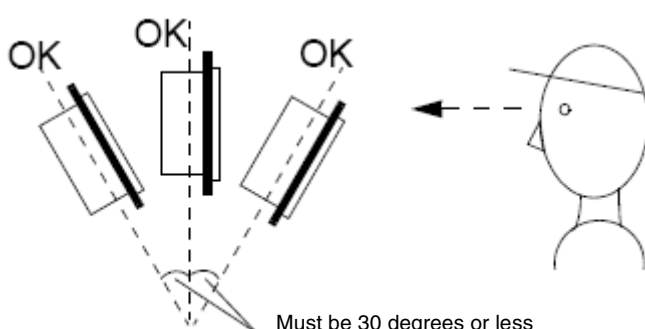
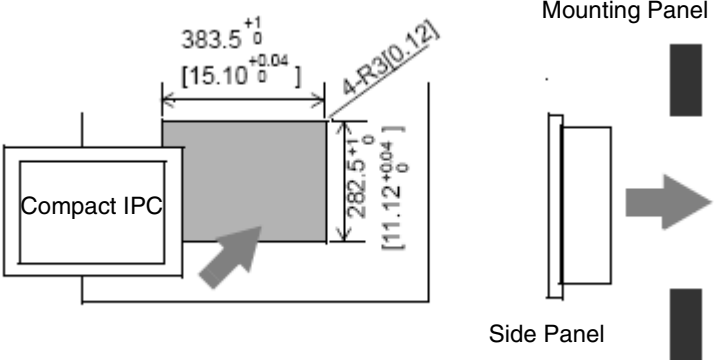
Step	Action
3	<p><b>Compact iPC Viewing Angle</b></p> <ul style="list-style-type: none"> <li>• Be sure that the panel's viewing angle is tilted no more than 30 degrees from parallel to the operator (i.e. operator is directly in front).</li> </ul>  <p>Must be 30 degrees or less</p> <ul style="list-style-type: none"> <li>• Avoid placing the Compact iPC next to other devices that might cause overheating.</li> <li>• Avoid using the Compact iPC where the ambient temperature will be higher than the allowed specification.</li> <li>• Keep the Compact iPC away from arc-generating devices such as magnetic switches and non-fuse breakers.</li> <li>• Avoid using the Compact iPC in environments where corrosive gases are present.</li> </ul>
4	<p><b>Insert the Compact iPC installation slot</b></p>  <p><b>Important</b> : Be sure the panel cut's actual measurements are the same as those given here, otherwise the Compact iPC may slip or fall out of the panel.</p>

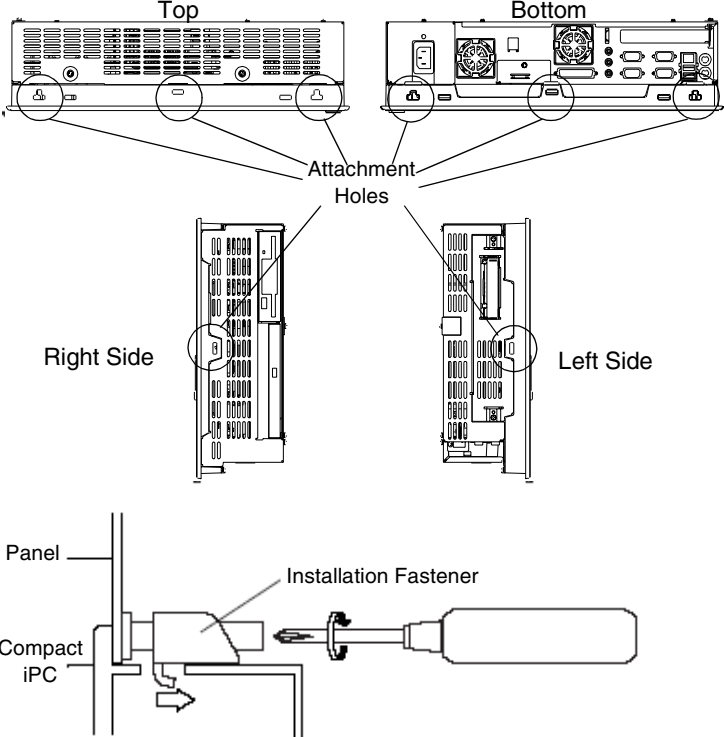
Step	Action
5	<p data-bbox="428 203 967 224"><b>Attach and Secure the Rear Installation Attachments</b></p> <p data-bbox="428 230 1152 279">Locate the Compact iPC's attachment holes, located on the top, bottom, and sides of the Unit.</p> <div data-bbox="428 316 1152 1047">  <p>The diagrams illustrate the locations of attachment holes on the Compact iPC unit. The top view shows three holes, the bottom view shows three holes, the right side view shows one hole, and the left side view shows one hole. A separate diagram shows an installation fastener being inserted into a hole in a panel, with labels for 'Panel', 'Compact iPC', and 'Installation Fastener'.</p> </div> <p data-bbox="428 1068 541 1091"><b>Important :</b></p> <ul data-bbox="428 1101 1159 1149" style="list-style-type: none"> <li>• Excessive torque may damage the Compact iPC unit.</li> <li>• To ensure a high degree of moisture resistance, the torque should be <math>0.5N\cdot m</math>.</li> </ul> <p data-bbox="428 1161 487 1183"><b>Note :</b></p> <ul data-bbox="428 1193 1159 1323" style="list-style-type: none"> <li>• Depending on the installation panel's thickness, etc., the number of installation fasteners used may need to be increased to provide the desired level of moisture resistance.</li> <li>• The corresponding installation attachments can be purchased as spare with the maintenance kit ref.: MPC YK 50 MNT KIT.</li> </ul>



---

## Connections to PLCs

# 10

---

### Connection to PLCs

#### Nano, Micro, Premium

This connection requires the use of connection cable **TSX PCX 1031** supplied with Unity Pro, PL7 Pro and PL7 Junior software.

This 2 meter-long cable is equipped with the following:

- A 9-contact SUB-D-type female connector for connection to the Compact iPC.
- A 5-contact microDin-type male connector for connection to the PLC.

---

#### Series 7

This concerns TSX 27 PLCs, and TSX/PMX 47/67/87/107 PLCs.

This connection requires the use of connection cable **FT20CBCL30** supplied with XTEL Pack software.

This 2.5 meter-long cable is equipped with the following:

- A 9-contact SUB-D- type female connector for connection to the Compact iPC.
- A 9-contact SUB-D-type male connector for connection to the PLC.

---

#### TSX 17

TSX 17 PLCs are connected via an accessory for converting the COM1 link (RS 232) into a RS 485 link (to be ordered separately).

Accessory reference number: **TSX 17 ACC PC**

---

#### April 2000/30000

This connection requires the use of connection cable **TSX PKIT 2040** (to be ordered separately).

This 2 meter-long cable is equipped with the following:

- A 9-contact SUB-D- type female connector for connection to the Compact iPC.
- A 9-contact SUB-D-type male connector for connection to the PLC.



---

# IV



---

## Appendices

### At a Glance

---

**Subject of this part**

This part contains the appendices relating to the products.

---

**What's in this Part?**

This part contains the following chapters:

Chapter	Chapter Name	Page
11	Accessories	97

---





---

## Accessories

11

---

### Accessories

#### List

Accessories are available as options. The list of accessories is shown below:

Description	Reference
RAM 512Mb 1,7G	<b>MPC YK05 RAM 512</b>
RAM 512Mb 667M	<b>MPC YK02 RAM 512</b>
Empty Compact Flash 512Mb	<b>MPC YN00 CFE 00N</b>
Maintenance Kit	<b>MPC YK50 MNT KIT</b>
Protection sheet	<b>MPC YK50 SPS KIT</b>
Industrial external PS/2 keyboard	<b>MPC YN00 KBD 00N</b>

---

