

Instruction Bulletin

ALTIVAR[®] 58 TRX Adjustable Speed Drive Controllers Installation Guide Type H Controllers

Retain for future use.



DANGER

HAZARDOUS VOLTAGE

- Read and understand this bulletin in its entirety before installing or operating ALTIVAR 58 *TRX* drive controllers. Installation, adjustment, repair, and maintenance of the drive controllers must be performed by qualified personnel.
- The user is responsible for conforming to all applicable code requirements with respect to grounding all equipment.
- Many parts in this drive controller, including printed wiring boards, operate at line voltage. **DO NOT TOUCH.** Use only electrically insulated tools.
- **DO NOT** short across DC bus capacitors or touch unshielded components or terminal strip screw connections with voltage present.
- Before servicing the drive controller:
 - Disconnect all power including external control power that may be present before servicing the drive controller.
 - Place a “DO NOT TURN ON” label on the drive controller disconnect.
 - Lock the disconnect in open position.
 - **WAIT TEN MINUTES** for the DC bus capacitors to discharge. Then follow the DC bus voltage measurement procedure on page 42 to verify that the DC voltage is less than 45 V. The drive controller LEDs are not accurate indicators of the absence of DC bus voltage.
- Install and close all covers before applying power or starting and stopping the drive controller.

Electrical shock will result in death or serious injury.

INTRODUCTION	5
Product Range	5
Product Features	5
Application Information	6
Revision Level and Related Documentation	6
RECEIVING AND PRELIMINARY INSPECTION	7
STORING AND SHIPPING	7
TECHNICAL CHARACTERISTICS	8
SPECIFICATIONS	17
DIMENSIONS	21
INSTALLATION PRECAUTIONS	26
Mounting and Temperature Conditions	28
ATV58HU09M2 to U72M2 and ATV58HU18N4 to U90N4	28
ATV58HU90M2 to D46M2 and ATV58HD12N4 to D79N4	29
MOUNTING IN A GENERAL PURPOSE METAL ENCLOSURE	30
MOUNTING IN A TYPE 12 OR IP54 METAL ENCLOSURE	31
Calculating Enclosure Size	31
Example	32
ELECTROMAGNETIC COMPATIBILITY (EMC)	33
WIRING	34
Bus Voltage Measurement Procedure	42
General Wiring Practices	45
Branch Circuit Connections	46
Output Wiring Precautions	56
Grounding	57
Power Terminals	58
Control Terminals	61
WIRING DIAGRAMS	63
Single-Phase Input	63
Three-Phase Input	64
RECOMMENDED BRANCH CIRCUIT PROTECTION DEVICES	65
Fuses	65
Circuit Breakers	65

USING DYNAMIC BRAKING	72
USING A LINE CONTACTOR.....	72
Output Contactor Wiring Diagram	72
EXTERNAL 24 V SUPPLY	74
FAULT RELAY.....	74
AVAILABLE MOTOR TORQUE	74
FACTORY SETTINGS	76
START UP.....	77
LIGHT EMITTING DIODES (LEDS)	79
PREVENTIVE MAINTENANCE.....	79
TROUBLESHOOTING AND MAINTENANCE.....	79
Procedure 1: Checking the Supply Voltage.....	80
Procedure 2: Checking the Peripheral Equipment	80
Fault Storage.....	81
APPENDIX A: OPTIONS AND ACCESSORIES	83

INTRODUCTION

The ALTIVAR 58 TRX (ATV58 TRX) series of adjustable frequency AC drive controllers is a Transparent Ready™ product line providing extended functionality and an extended horsepower range for the ALTIVAR 58 AC drive family. The ATV58 TRX series includes an analog output, expanded firmware capabilities, and a horsepower range up to 500 hp. As a Transparent Ready product equipped with an Ethernet connection, the ATV58 TRX product line can be configured, controlled, monitored, and diagnosed over an Ethernet network with a standard Web browser. No special software or drivers are needed. The ALTIVAR 58 TRX controllers are available August 2002

Product Range

The ATV58 TRX drive controllers range from:

- 1 to 75 hp (0.75 to 55 kW) constant torque, 400/460 V, three-phase input
- 1 to 500 hp (0.75 kW to 315 kW) variable torque, 400/460 V, three-phase input
- 0.5 to 7.5 hp (0.37 to 5.5 kW) constant torque, 208/230 V, single-phase input
- 0.5 to 30 hp (0.37 to 22 kW) variable torque, 208/230 V, single-phase input
- 2 to 40 hp (1.5 to 30 kW) constant torque (50 hp variable torque), 208/230 V, three-phase input.

Product Features

ATV58 TRX drive controllers ATV58HD28N4 to ATV58HD79N4 and ATV58HD16M2 to ATV58HD46M2 have built-in line reactors.

Most ATV58 TRX drive controllers are available with a built-in EMC filter. Separately-mounted EMC filters are available for the full product range. The EMC filter reduces conducted and radiated emissions. It complies with product standards IEC 61800-3 and EN 61800-3 for drive controllers, meeting the requirements of the European directive on EMC.

The 5–25 hp 460 Vac variable torque drive controllers are available without the integrated EMC filter for 460 Vac installations where the filter is not required. This allows the controller to be rated for additional horsepower at 460 Vac as shown in Table 10 on page 16. An “X” in the catalog number indicates that the drive controller does not have the EMC filter.

The ATV58 TRX controllers accept all of the current I/O options, communication card options, and hardware options, such as ventilation fan kits and conduit box kits. See appendix A for a complete list of options.

Application Information

The 125-500 hp drive controllers are listed in this instruction bulletin with ratings typically used for variable torque applications. With proper selection, this range of controllers can also be used in constant torque applications, such as compressors, conveyors, and extruders, where high performance is not required at low speeds. The 125–500 hp product ratings in this instruction bulletin are for applications that require 100% rated torque down to 6 Hz. If the application requires more than 110% transient torque for one minute, select the appropriate horsepower product. For assistance with selecting the proper AC drive controller for constant torque applications, consult your local Square D drives specialist.

Application information is also available in product data bulletin SC100, *Adjustable Frequency Controllers Application Guide* available at www.SquareD.com, or the NEMA Standards Publication: *Application Guide For AC Adjustable Speed Drive Systems*.

Revision Level and Related Documentation

This instruction bulletin covers the technical characteristics, specifications, installation, and wiring of all ATV58 TRX Type H drive controllers. It replaces VVDED397048US R8/01 dated August 2001.

For information on programming and troubleshooting the drive controller, refer to the keypad display instruction bulletin, VVDED397047US.

RECEIVING AND PRELIMINARY INSPECTION

CAUTION

EQUIPMENT DAMAGE HAZARD

Do not operate or install any drive controller that appears damaged.

Failure to follow this instruction can result in injury or equipment damage.

Before installing the drive controller, read this manual and follow all precautions.

Before removing the drive controller from its packaging, verify that the carton is not damaged from shipping. Damage to the carton usually indicates improper handling. If any damage is found, notify the carrier and your Square D representative.

After removing the drive controller from its packaging, inspect it for damage. If any damage is found, notify the carrier and your sales representative. Verify that the drive controller nameplate and label conform to the packing slip and corresponding purchase order.

STORING AND SHIPPING

If the drive controller is not being immediately installed, store it in a clean, dry area where the ambient temperature is between -13 and +149 °F (-25 and +65 °C). If the drive controller must be shipped to another location, use the original shipping material and carton to protect the drive controller.

TECHNICAL CHARACTERISTICS

Tables 1 through 10 show the ratings of the ATV58 TRX Type H drive controllers.

A drive controller usually has more than one rating. The rating depends on the application, incoming line power, and how the product is configured. On 5–25 hp 460 Vac devices, the rating changes depending on whether the product has an internally-mounted EMC filter.

The table heading “Variable Torque Low Noise” conveys information about the switching frequency setting. A higher switching frequency setting reduces audible motor noise. For more information on this and other drive control applications, go to www.SquareD.com and search for “AC Drive Application Guide.”

**Table 1: Constant Torque, 208/230 V Ratings, Single-Phase Input
 • Three-Phase Output, Switching Frequency @4 kHz**

Product Frame Size	Drive Controller Catalog Number ^[1]	Motor Power 208/230 V		Rated Output Current A	Transient Output Current A	Total Dissipated Power @ Rated Load W
		kW	hp			
1	ATV58HU09M2•	0.37	0.5	2.3	3.1	42
1	ATV58HU18M2•	0.75	1	4.1	5.6	64
2	ATV58HU29M2•	1.5	2	7.8	10.6	107
2	ATV58HU41M2•	2.2	3	11	15.0	156
3	ATV58HU72M2• ^[2]	3	4	13.7	18.6	160
4	ATV58HU90M2• ^[2]	4	5	18.2	24.8	176
4	ATV58HD12M2• ^[2]	5.5	7.5	24.2	32.9	204

[1] Refer to catalog 8806CT9901 to complete the catalog number.

[2] When these drive controllers are used with a single-phase input, a line reactor (3% minimum) must be used.

Table 2: Variable Torque Low Noise, 208/230 V Ratings, Single-Phase Input • Three-Phase Output, Switching Frequency: ATV58HU09M2–D12M2 @ 8 kHz, ATV58HD16M2–D46M2 @ 4kHz

Product Frame Size	Drive Controller Catalog Number ^[1]	Motor Power 208/230 V		Rated Output Current A	Transient Output Current A	Total Dissipated Power @ Rated Load W
		kW	hp			
1	ATV58HU09M2•	0.37	0.5	2.5	2.8	42
1	ATV58HU18M2•	0.75	1	4.8	5.3	64
2	ATV58HU29M2•	1.5	2	7.8	8.6	107
2	ATV58HU41M2•	2.2	3	11	12.1	156
3	ATV58HU72M2• ^[2]	3	4	14.3	15.7	160
4	ATV58HU90M2• ^[2]	4	5	17.5	19.3	176
4	ATV58HD12M2• ^[2]	5.5	7.5	25.3	27.8	204
6	ATV58HD16M2• ^[2]	7.5	10	30.8	33.9	323
6	ATV58HD23M2• ^[2]	11	15	46.2	50.8	550
7	ATV58HD28M2• ^[2]	15	20	60	66.0	745
7	ATV58HD33M2• ^[2]	18.5	25	75	82.5	895
7	ATV58HD46M2• ^[2]	22	30	88	96.8	900

[1] Refer to catalog 8806CT9901 to complete the catalog number.

[2] When these drive controllers are used with a single-phase input, a line reactor (3% minimum) must be used.

**Table 3: Constant Torque, 208/230 V Ratings, Three-Phase Input • Three-Phase Output, Switching Frequency:
 ATV58HU29M2–D23M2 @ 4kHz,
 ATV58HD28M2–D46M2 @ 2 kHz**

Product Frame Size	Drive Controller Catalog Number ^[1]	Motor Power 208/230 V		Rated Output Current In A	Transient Output Current A	Total Dissipated Power @ Rated Load W
		kW	hp			
2	ATV58HU29M2•	1.5	2	7.8	10.6	107
2	ATV58HU41M2•	2.2	3	11	15.0	160
3	ATV58HU54M2•	3	4	13.7	18.6	190
3	ATV58HU72M2•	4	5	18.2	24.8	240
4	ATV58HU90M2	5.5	7.5	24.2	32.9	255
4	ATV58HD12M2•	7.5	10	31	42.2	350
6	ATV58HD16M2•	11	15	47	63.9	745
6	ATV58HD23M2•	15	20	60	81.6	895
7	ATV58HD28M2•	18.5	25	75	102.0	900
7	ATV58HD33M2•	22	30	88	119.7	1030
7	ATV58HD46M2•	30	40	116	157.8	1315

[1] Refer to catalog 8806CT9901 to complete the catalog number.

**Table 4: Constant Torque Low Noise, 208/230 V Ratings, Three-Phase Input • Three-Phase Output, Switching Frequency: ATV58HD16M2–D23M2 @ 8 kHz,
 ATV58HD28M2–D46M2 @ 4 kHz**

Product Frame Size	Drive Controller Catalog Number ^[1]	Motor Power 208/230 V		Rated Output Current A	Transient Output Current A	Total Dissipated Power @ Rated Load W
		kW	hp			
6	ATV58HD16M2•	7.5	10	31	42.2	745
6	ATV58HD23M2•	11	15	47	63.9	895
7	ATV58HD28M2•	15	20	60	81.6	900
7	ATV58HD33M2•	18.5	25	75	102.0	1030
7	ATV58HD46M2•	22	30	88	119.7	1315

[1] Refer to catalog 8806CT9901 to complete the catalog number.

**Table 5: Variable Torque, 208/230 V Ratings, Three-Phase Input •
Three-Phase Output, Switching Frequency:
ATV58HU29M2–D23M2 @ 4 kHz,
ATV58HD28M2–D46M2 @ 2 kHz**

Product Frame Size	Drive Controller Catalog Number ^[1]	Motor Power 208/230 V		Rated Output Current	Transient Output Current	Total Dissipated Power @ Rated Load
		kW	hp	A	A	W
2	ATV58HU29M2•	1.5	2	7.8	8.6	107
2	ATV58HU41M2•	2.2	3	11	12.1	158
3	ATV58HU54M2•	3	4	14.3	15.7	190
3	ATV58HU72M2•	4	5	16.7	18.4	198
4	ATV58HU90M2	5.5	7.5	24.2	26.6	235
4	ATV58HD12M2•	7.5	10	30.8	33.9	323
6	ATV58HD16M2•	11	15	46.2	50.8	550
6	ATV58HD16M2•	15	20	60	66.0	745
6	ATV58HD23M2•	18.5	25	75	82.5	895
7	ATV58HD28M2•	22	30	88	96.8	900
7	ATV58HD33M2•	30	40	116	127.6	1030
7	ATV58HD46M2•	37	50	143	157.3	1315

[1] Refer to catalog 8806CT9901 to complete the catalog number.

Table 6: Variable Torque Low Noise, 208/230 V Ratings, Three-Phase Input • Three-Phase Output, Switching Frequency: ATV58HU29M2–D23M2 @ 8 kHz, ATV58HD28M2–D46M2 @ 4 kHz

Product Frame Size	Drive Controller Catalog Number ^[1]	Motor Power 208/230 V		Rated Output Current	Transient Output Current	Total Dissipated Power @ Rated Load
		kW	hp	A	A	W
2	ATV58HU29M2•	1.5	2	7.5	8.3	107
2	ATV58HU41M2•	2.2	3	10.6	11.7	158
3	ATV58HU54M2•	3	4	14.3	15.7	190
3	ATV58HU72M2•	4	5	16.7	18.4	198
4	ATV58HU90M2	5.5	7.5	24.2	26.6	235
4	ATV58HD12M2•	7.5	10	30.8	33.9	323
6	ATV58HD16M2•	11	15	46.2	50.8	745
6	ATV58HD23M2•	15	20	60	66.0	890
7	ATV58HD28M2•	18.5	25	75	82.5	980
7	ATV58HD33M2•	22	30	88	96.8	975
7	ATV58HD46M2•	30	40	116	127.6	1215

[1] Refer to catalog 8806CT9901 to complete the catalog number.

Table 7: Constant Torque, 400 /460 V Ratings, Three-Phase Input • Three-Phase Output, Switching Frequency: ATV58HU18N4–D46N4 @ 4 kHz, ATV58HD54N4–D79N4 @ 2 kHz

Product Frame Size	Drive Controller Catalog Number ^[1]	Motor Power		Rated Output Current	Transient Output Current	Total Dissipated Power @ Rated Load
		400 V kW	460 V hp	A	A	W
2	ATV58HU18N4•	0.75	1	2.3	3.1	57
2	ATV58HU29N4•	1.5	2	4.1	5.6	97
2	ATV58HU41N4•	2.2	3	5.8	7.9	120
3	ATV58HU54N4•	3	4	7.8	10.6	170
3	ATV58HU72N4•	4	5	10.5	14.3	210
3	ATV58HU90N4	5.5	7.5	13	17.7	295
4	ATV58HD12N4•	7.5	10	17.6	23.9	360
4	ATV58HD16N4•	11	15	24.2	32.9	480
5	ATV58HD23N4•	15	20	33	44.9	590
6	ATV58HD28N4•	18.5	25	40.7	55.4	421
6	ATV58HD33N4•	22	30	48.4	65.8	491
6	ATV58HD46N4•	30	40	66	89.8	625
7	ATV58HD54N4•	37	50	79.2	107.7	677
7	ATV58HD64N4•	45	60	93.5	127.2	837
7	ATV58HD79N4•	55	75	115.5	157.1	1090

[1] Refer to catalog 8806CT9901 to complete the catalog number.

Table 8: Constant Torque Low Noise, 400/460 V Ratings, Three-Phase Input • Three-Phase Output, Switching Frequency: ATV58HD28N4–D46N4 @ 8 kHz, ATV58HD54N4–D79N4 @ 4 kHz

Product Frame Size	Drive Controller Catalog Number ^[1]	Motor Power		Rated Output Current	Transient Output Current	Total Dissipated Power @ Rated Load
		400 V kW	460 V hp	A	A	W
6	ATV58HD28N4•	15	20	33	44.9	429
6	ATV58HD33N4•	18.5	25	40.7	55.4	524
6	ATV58HD46N4•	22	30	48.4	65.8	561
7	ATV58HD54N4•	30	40	66	89.8	627
7	ATV58HD64N4•	37	50	79.2	107.7	677
7	ATV58HD79N4•	45	60	93.5	127.2	1007

[1] Refer to catalog 8806CT9901 to complete the catalog number.

**Table 9: Variable Torque, 400/460 V Ratings, Three-Phase Input • Three-Phase Output, Switching Frequency:
ATV58HU18N4–D23N4 @ 8kHz, ATV58HD28N4–D46N4 @ 4 kHz,
ATV58HD54N4–C33N4X @ 2 kHz**

Product Frame Size	Drive Controller Catalog Number [1]	Motor Power		Rated Output Current	Transient Output Current	Total Dissipated Power @ Rated Load
		400 V kW	460 V hp	A	A	W
2	ATV58HU18N4•	0.75	1	2.1	2.3	57
2	ATV58HU29N4•	1.5	2	3.4	3.7	97
2	ATV58HU41N4•	2.2	3	4.8	5.3	119
3	ATV58HU54N4•	3	4	6.2	6.8	170
3	ATV58HU72N4•	4	5	7.6	8.4	209
3	ATV58HU90N4	5.5	7.5	11	12.1	291
4	ATV58HD12N4•	7.5	10	14	15.4	352
4	ATV58HD16N4•	11	15	21	23.1	472
5	ATV58HD23N4•	15	20	27	29.7	584
6	ATV58HD28N4• [2]	18.5	25	34	37.4	474
6	ATV58HD28N4•	22	30	40	44.0	618
6	ATV58HD33N4•	30	40	52	57.2	713
6	ATV58HD46N4•	37	50	65	71.5	770
7	ATV58HD54N4•	45	60	77	84.7	987
7	ATV58HD64N4•	55	75	96	105.6	1075
7	ATV58HD79N4	75	100	124	136.4	1439
8	ATV58HC10N4X• [3]	90	125	156	172	2250
9	ATV58HC13N4X• [3]	110	150	180	198	2750
9	ATV58HC15N4X• [3]	132	200	240	264	3300
9	ATV58HC19N4X• [3]	160	250	302	332	4000
10	ATV58HC23N4X• [3]	200	300	361	397	5000
10	ATV58HC25N4X• [3]	220	350	414	455	5500
10	ATV58HC28N4X• [3]	250	400	477	525	6250
10	ATV58HC31N4X• [3]	280	450	515	567	7000
10	ATV58HC33N4X• [3]	315	500	590	649	7875

[1] Refer to catalog 8806CT9901 to complete the catalog number.

[2] The ATV58HD28N4 drive controller is rated for 8 kHz operation at 18.5 kW/25 hp.

[3] An "X" in the catalog number indicates that internal EMC filters are not available for these products.

Table 10: Variable Torque Low Noise, 400/460 V Ratings, Three-Phase Input • Three-Phase Output: Switching Frequency: ATV58HU18N4–D46N4 @ 8 kHz, ATV58HD54N4–D79N4 @ 4 kHz

Product Frame Size	Drive Controller Catalog Number ^[1]	Motor Power		Rated Output Current	Transient Output Current	Total Dissipated Power @ Rated Load
		400 V kW	460 V hp	A	A	W
2	ATV58HU18N4•	0.75	1	2.1	2.3	57
2	ATV58HU29N4•	1.5	2	3.4	3.7	97
2	ATV58HU41N4•	2.2	3	4.8	5.3	119
3	ATV58HU54N4X•	[2]	5	7.6	8.4	209
3	ATV58HU72N4X•	[2]	7.5	11	12.1	291
3	ATV58HU90N4X•	[2]	10	14	15.4	352
4	ATV58HD12N4X•	[2]	15	21	23.1	472
4	ATV58HD16N4X•	[2]	20	27	29.7	584
5	ATV58HD23N4X•	[2]	25	34	37.4	654
6	ATV58HD28N4•	18.5	25	34	37.4	502
6	ATV58HD33N4•	22	30	40	44.0	584
6	ATV58HD46N4•	30	40	52	57.2	714
7	ATV58HD54N4•	37	50	65	71.5	732
7	ATV58HD64N4•	45	60	77	84.7	904
7	ATV58HD79N4•	55	75	96	105.6	1183

[1] Refer to catalog 8806CT9901 to complete the catalog number

[2] . An "X" in the catalog number indicates that the drive controller does not have an EMC filter. This product is for 460 Vac applications. See Table 9 for 400 Vac rated product in this hp range. Refer to page 5 of this bulletin for more application and rating information.

SPECIFICATIONS

Table 11: Environmental Specifications

NOTE: Discoloration of drive controller plastic pieces will occur if exposed to direct sunlight.

Enclosure type	ATV58HU09M2 to U90N4: IP20/open type controllers according to Standard EN50178. ATV58HU90M2 to D46M2, ATV58HD12N4 to D79N4: UL Type 1 with conduit connection kit. ATV58HC10N4X to C33N4X: IP20 on all surfaces except the bottom. IP00 on the bottom due to the power connections.
Resistance to vibrations	According to IEC 60068-2-6: 1.5 mm zero to peak from 3 to 13 Hz 1 gn from 13 to 200 Hz ATV58HC10N4X–C33N4X: 0.6 gn from 10 to 55 Hz
Resistance to shocks	According to IEC 60068-2-27: 15 g, 11 ms
Ambient pollution degree	ATV58HU09M2–D12M2 and ATV58HU18N4–D23N4: Pollution degree 2 conforming to IEC 60664-1, EN50718, and NEMA ICS-1. ATV58HD16M2–D46M2 and ATV58HD28N4–D79N4: Pollution degree 3 conforming to IEC 60664-1, EN50718, and NEMA ICS-1. ATV58HC10N4X–C33N4X: Pollution degree 2 conforming to IEC 60664-1, EN 50718, and NEMA ICS-1. Protect the drive controller against dust, corrosive gas, and falling liquid.
Maximum relative humidity	95% maximum, non-condensing and without dripping according to IEC 60068-2-3. Provide a heating system if there is condensation.
Maximum ambient temperature	Storage: -25 to +65 °C (-13 to +149 °F) Operation: Drive controllers ATV58HU09M2–U72M2 and ATV58HU18N4–U90N4: ^[1] -10 to +50 °C (+14 to 122 °F) without derating -10 to +60 °C (+14 to 140 °F) with fan kit ^[2] and derating of the current 2.2% per °C above 50 °C Drive controllers ATV58HU90M2–D46M2 and ATV58HD12N4–D79N4: -10 to +40 °C (+14 to 104 °F) without derating -10 to +50 °C (+14 to 122 °F) with fan kit ^[1] and derating of the current 2.2% per °C above 40 °C Drive controllers ATV58HC10N4X–C33N4X: -10 to +40 °C (+14 to 104 °F) without derating -10 to +50 °C (+14 to 122 °F) with derating of the current 2.2% per °C above 40 °C
Altitude	3300 ft (1000 m) maximum without derating; derate the output current by 1% for each additional 330 ft (100 m)
Operating position	Vertical, ±10°, with power terminals at the bottom

[1] ATV58HU54N4X, ATV58HU72N4X, and ATV58HU90N4X can be used at their highest VT rating in a 40 °C maximum ambient temperature.

[2] See Appendix A for list of accessories.

Table 12: Electrical Specifications

Input voltage	208 V -15% to 230 V +15% single-phase input 208 V -15% to 230 V +15% three-phase input 400 V -15% to 460 V + 20% three-phase input ^[1]
Input frequency	50/60 Hz ±5%
Output voltage	Three-phase output, maximum voltage equal to input voltage
Galvanic isolation	Galvanic isolation between power and control (inputs, outputs, supplies)
Output frequency	0.1 to 60 Hz (configurable to 500 Hz with programming options) ^[2]
Switching frequency	4 kHz, configurable with programming accessories ^[2] ATV58HU09M2–D12M2 and ATV58HU18N4–D23N4: 0.5 - 1 - 2 - 4 - 8 kHz without derating 12 - 16 kHz with derating of one hp rating in steady state 12 - 16 kHz without derating and with reduced duty cycle ^[3] ATV58HD16M2–D23M2 and ATV58HD28N4–D46N4: 0.5 - 1 - 2 - 4 - 8 kHz without derating 8 - 12 kHz with derating of one hp rating in steady state 8 - 12 kHz without derating and with reduced duty cycle ^[3] ATV58HD28M2–D46M2 and ATV58HD54N4–D79N4: 0.5 - 1 - 2 - 4 kHz without derating 8 kHz with derating of one hp rating in steady state 4 - 8 kHz without derating and with reduced duty cycle ^[3] ATV58HC10N4X–C33N4X: 0.5 - 1 - 2 kHz without derating 4 kHz without derating and with reduced duty cycle ^[3] 4 kHz with derating of one hp rating in steady state
Speed range	1:100 open loop (for example 0.6 Hz to 60 Hz) 1:10 open loop for ATV58HC10N4X–C33N4X
Speed regulation	1% of rated motor speed without adjustments or feedback. ±0.1% of rated motor speed with optional analog I/O card and appropriate tachometer feedback. ^[2] ±0.02% of rated motor speed with optional digital I/O card and appropriate encoder feedback. ^[2] 3% for ATV58HC10N4X–C33N4X
Efficiency	97% at full load typical.
Displacement power factor	98% through speed range.

[1] Input voltage is 460 V, -10%, +15% on ATV58HU54N4X–D23N4X controllers as rated in Table 10 on page 16. Input voltage is 400 V -15% to 460 V +10% on ATV58HC13N4X–C33N4X.

[2] See Appendix A for a list of accessories.

[3] The drive controller can be configured to reduce switching frequency if the drive thermal state reaches 95%. When the drive thermal state returns to 70%, the switching frequency returns to the set value. If the duty cycle (drive controller run time) does not exceed 60% (36 second maximum for a 60 second cycle) derating is not required.

[4] Motor thermal protection can be set between 25 and 136% of the drive controller rating.

Table 12: Electrical Specifications (Continued)

Motor control algorithm	Sensorless flux vector control with a pulse width modulated (PWM) output wave form.
DC injection braking	Automatically on stopping as soon as frequency drops below 0.1 Hz for 0.5 seconds.
Braking torque	30% of nominal motor torque without dynamic braking (typical value). Up to 150% with the dynamic braking option (for constant torque ratings).
Transient output current	160% of nominal NEC rated motor current for 60 seconds (for constant torque ratings). 110% of nominal motor current for 60 seconds (for variable torque ratings).
Transient motor torque	200% of nominal motor torque (typical value at ±10%) for 2 seconds (for constant torque ratings). 170% of nominal motor torque (typical value at ±10%) for 60 seconds (for constant torque ratings).
Drive controller protection	Protection against short circuits: <ul style="list-style-type: none"> • between output phases • between output phases and ground • on outputs of internal supplies Thermal protection against overheating and overcurrent. Undervoltage and overvoltage faults. Protection against single-phase input operation on the three-phase drive controllers.
Motor protection	Thermal protection integrated in the drive controller by continuous calculation of I^2t , taking motor speed into account. ^[4] Motor thermal state is retained during loss of power. Motor thermal protection can be modified with a programming option to correspond to the type of motor cooling. ^[2] Protection against motor phase loss. Protection by motor thermal sensors with analog option card. ^[2]

[1] Input voltage is 460 V, -10%, +15% on ATV58HU54N4X–D23N4X controllers as rated in Table 10 on page 16. Input voltage is 400 V -15% to 460 V +10% on ATV58HC13N4X–C33N4X.

[2] See Appendix A for a list of accessories.

[3] The drive controller can be configured to reduce switching frequency if the drive thermal state reaches 95%. When the drive thermal state returns to 70%, the switching frequency returns to the set value. If the duty cycle (drive controller run time) does not exceed 60% (36 second maximum for a 60 second cycle) derating is not required.

[4] Motor thermal protection can be set between 25 and 136% of the drive controller rating.

Table 12: Electrical Specifications (Continued)

Codes and standards	UL Listed per UL 508C as incorporating electronic overload protection: UL File E164874 CCN NMMS ATV58HU09M2 to D46M2 ATV58HU18N4 to D79N4 ATV58HC10N4X to C33N4X CSA Certified to CSA C22.2 No. 14. CSA File LR96921 Class 3211 06 ATV58HU09M2 to D46M2 ATV58HU18N4 to D79N4 CE Marked Conforms to applicable NEMA ICS, NFPA, IEC, and ISO 9001 standards.
<p>[1] Input voltage is 460 V, -10%, +15% on ATV58HU54N4X–D23N4X controllers as rated in Table 10 on page 16. Input voltage is 400 V -15% to 460 V +10% on ATV58HC13N4X–C33N4X.</p> <p>[2] See Appendix A for a list of accessories.</p> <p>[3] The drive controller can be configured to reduce switching frequency if the drive thermal state reaches 95%. When the drive thermal state returns to 70%, the switching frequency returns to the set value. If the duty cycle (drive controller run time) does not exceed 60% (36 second maximum for a 60 second cycle) derating is not required.</p> <p>[4] Motor thermal protection can be set between 25 and 136% of the drive controller rating.</p>	

DIMENSIONS

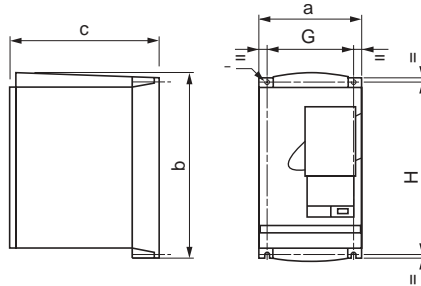

Figure 1: ATV58H Dimensions

Table 13: ATV58H Dimensions

Product Frame Size	Catalog No. ATV58H	a in. (mm)	b in. (mm)	c in. (mm)	G in. (mm)	H in. (mm)	Ø in. (mm)	Weight lb (kg)
1	U09M2, U18M2	4.45 (113)	8.11 (206)	6.58 (167)	3.78 (96)	7.48 (190)	0.20 (5)	4.9 (2.2)
2	U29M2, U41M2, U18N4, U29N4, U41N4	5.91 (150)	9.06 (230)	7.24 (184)	5.20 (133)	8.27 (210)	0.20 (5)	8.4 (3.8)
3	U54M2, U72M2, U54N4, U72N4, U90N4	6.89 (175)	11.26 (286)	7.24 (184)	6.10 (155)	10.63 (270)	0.22 (5.5)	15.2 (6.9)
4	U90M2, D12M2, D12N4, D16N4	9.06 (230)	12.80 (325)	8.27 (210)	7.9 (200)	12.20 (310)	0.22 (5.5)	26 (11.9)
5	D23N4	9.06 (230)	16.35 (415)	8.27 (210)	7.9 (200)	15.75 (400)	0.22 (5.5)	31 (13.9)

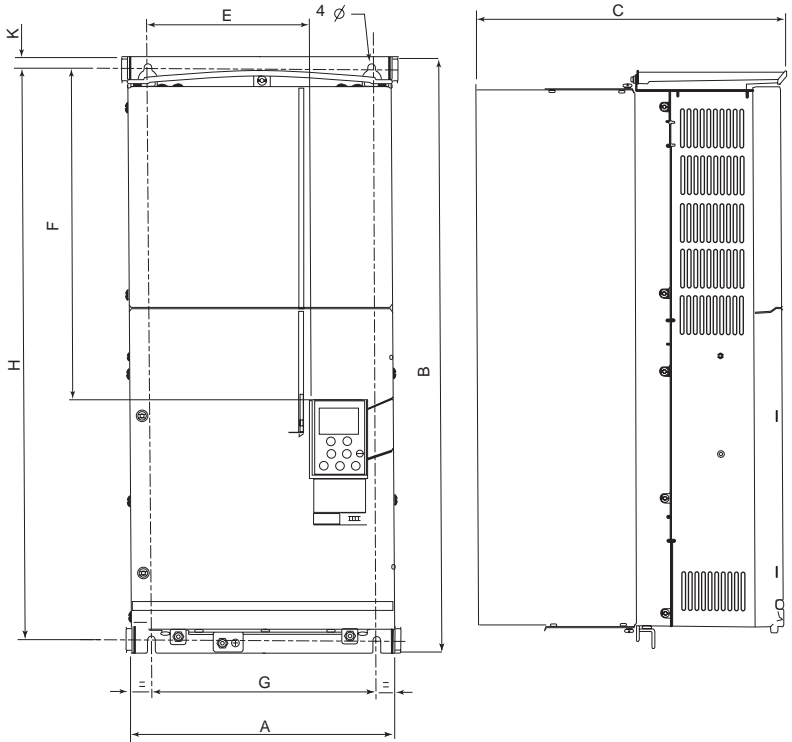

Figure 2: ATV58H**** Dimensions

Table 14: ATV58H**** Dimensions

Product Frame Size	Catalog No. ATV58H****	A in. (mm)	B in. (mm)	C in. (mm)	E in. (mm)	F in. (mm)	G in. (mm)	H in. (mm)	K in. (mm)	∅ in. (mm)	Weight lb (kg)
6	D16M2, D23M2, D28N4, D33N4, D46N4	9.45 (240)	21.65 (550)	11.14 (283)	5.75 (146)	12.05 (306)	8.07 (205)	20.87 (530)	0.39 (10)	0.28 (7)	75 (34)
7	D28M2, D33M2, D46M2, D54N4, D64N4, D79N4	13.78 (350)	25.59 (650)	11.97 (304)	9.29 (236)	15.35 (390)	11.81 (300)	24.37 (619)	0.39 (10)	0.36 (9)	126 (57)

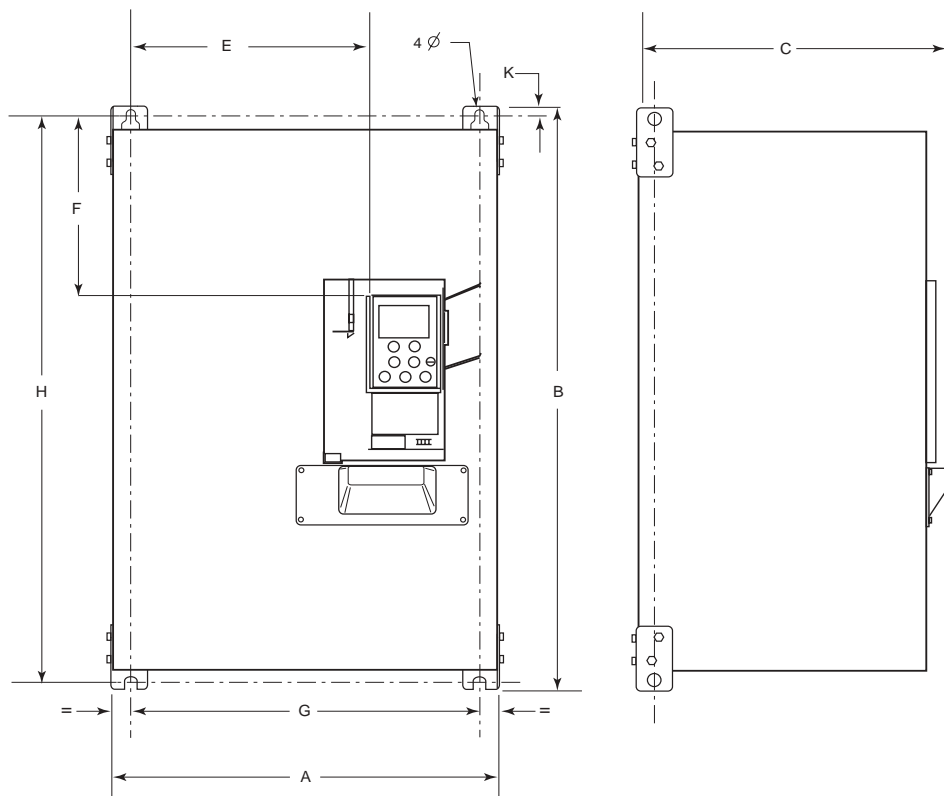

Figure 3: ATV58H Dimensions

Table 15: ATV58H Dimensions

Product Frame Size	Catalog No. ATV58H.....	A in. (mm)	B in. (mm)	C in. (mm)	E in. (mm)	F in. (mm)	G in. (mm)	H in. (mm)	K in. (mm)	Ø in. (mm)	Weight lb (kg)
8	C10N4X	14.6 (370)	25.2 (640)	14.2 (360)	9.25 (235)	8.25 (210)	12.63 (321)	24.5 (622)	0.50 (13)	0.50 (13)	108 (49)

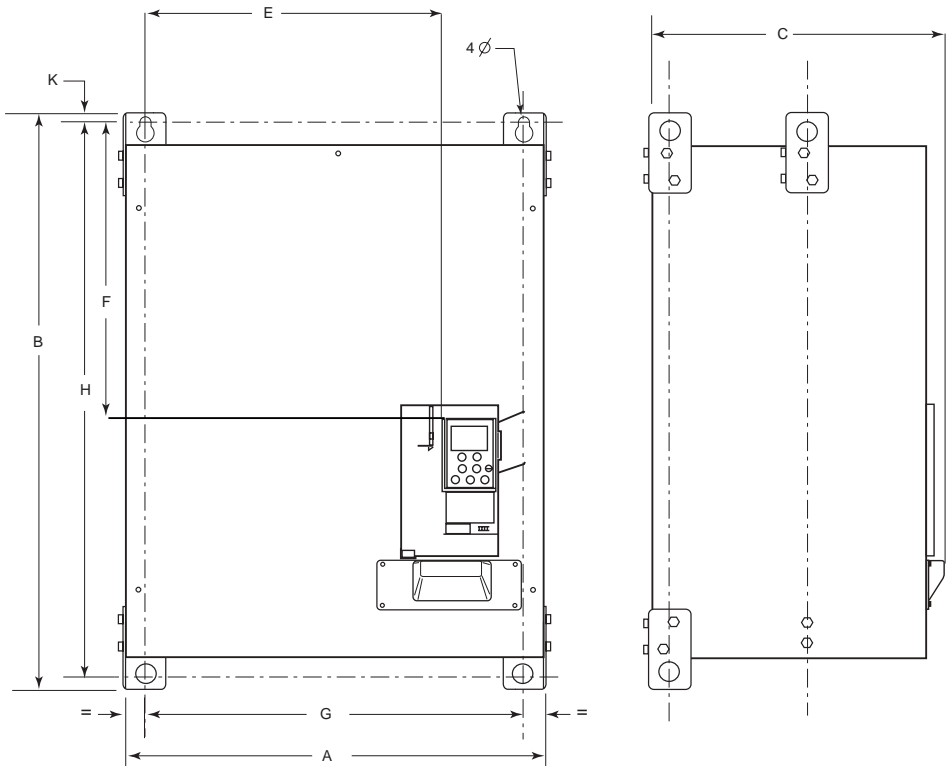

Figure 4: ATV58H**** Dimensions

Table 16: ATV58H**** Dimensions

Product Frame Size	Catalog No. ATV58H****	A in. (mm)	B in. (mm)	C in. (mm)	E in. (mm)	F in. (mm)	G in. (mm)	H in. (mm)	K in. (mm)	Ø in. (mm)	Weight lb (kg)
9	C13N4X C15N4X C19N4X	18.9 (480)	27.2 (690)	15.7 (400)	13.38 (340)	14.25 (362)	16.75 (425)	26.00 (660)	0.50 (13)	0.50 (13)	169 (77)

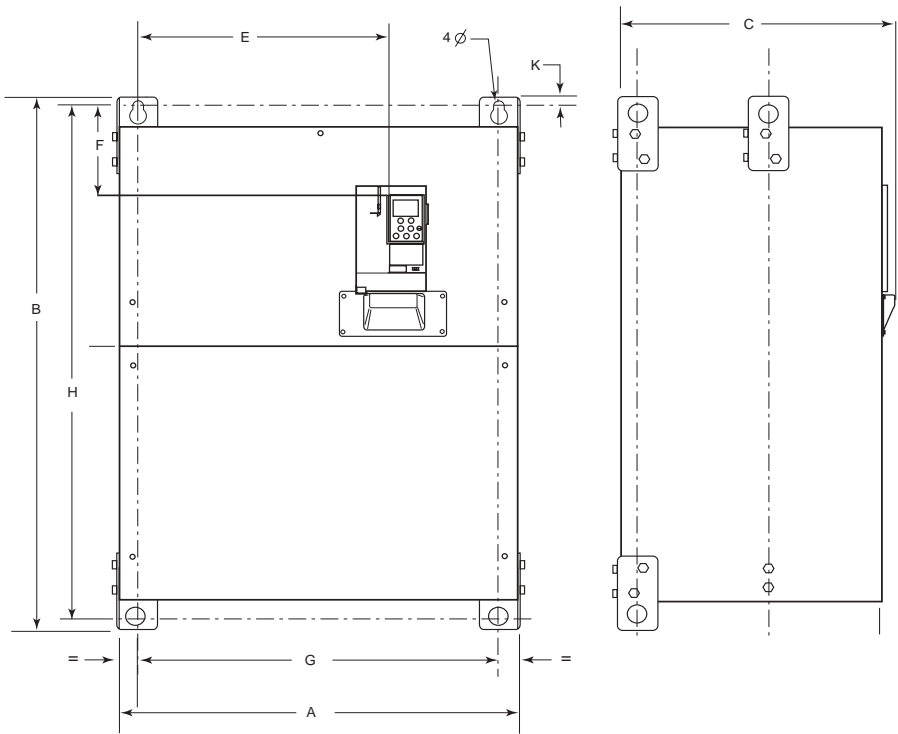

Figure 5: ATV58H Dimensions

Table 17: ATV58H Dimensions

Product Frame Size	Catalog No. ATV58H*****	A in. (mm)	B in. (mm)	C in. (mm)	E in. (mm)	F in. (mm)	G in. (mm)	H in. (mm)	K in. (mm)	∅ in. (mm)	Weight lb (kg)
10	C23N4X C25N4X C28N4X C31N4X C33N4X	26 (660)	37.6 (955)	17.3 (440)	15.88 (403)	7.00 (178)	23.50 (597)	36.38 (924)	0.50 (13)	0.50 (13)	370 (168)

INSTALLATION PRECAUTIONS

- The ATV58 TRX drive controller must be installed in a suitable environment. The environment around the drive controller must not exceed the pollution degree requirements defined in NEMA ICS-1 or IEC 60664. Refer to the ambient pollution degree ratings in Table 11.
- Install the drive controller vertically, +/- 10°, with the power terminals at the bottom. Do not place the drive controller near any heat sources.
- Leave at least 0.4 in. (10 mm) in front of the drive controller.
- Verify that the voltage and frequency of the input line match the drive controller nameplate rating.
- Install a disconnect device on the input line side of the drive controller in accordance with national and local codes.
- Overcurrent protection is required. Refer to Tables 34–40 on pages 66–71 for recommended overcurrent protection.

DANGER

HAZARDOUS VOLTAGE

Before working on this equipment:

- Turn off all power.
- Place a “DO NOT TURN ON” label on the drive controller disconnect.
- Lock the disconnect in the open position.

Failure to follow this instruction will result in death or serious injury.

- Figures 6–8 on pages 27–28 show the minimum clearances required around each drive controller for unobstructed air flow. **Do not** use these clearances as the minimum enclosure size for proper thermal dissipation.

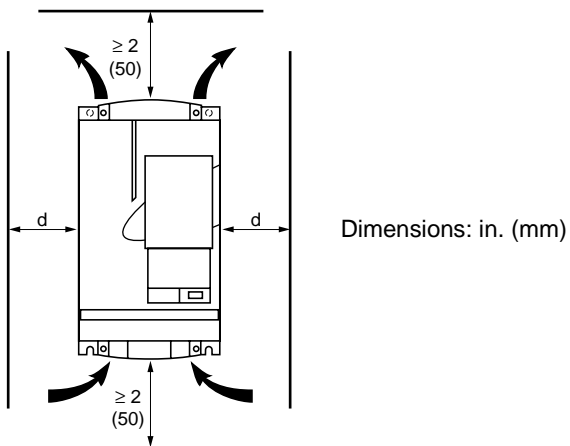

Figure 6: Minimum Clearances: ATV58HU18N4 to D23N4

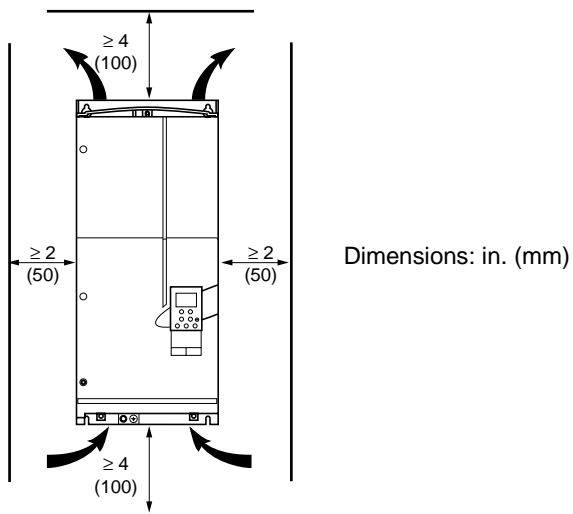

Figure 7: Minimum Clearances: ATV58HD25N4X to D79N4X

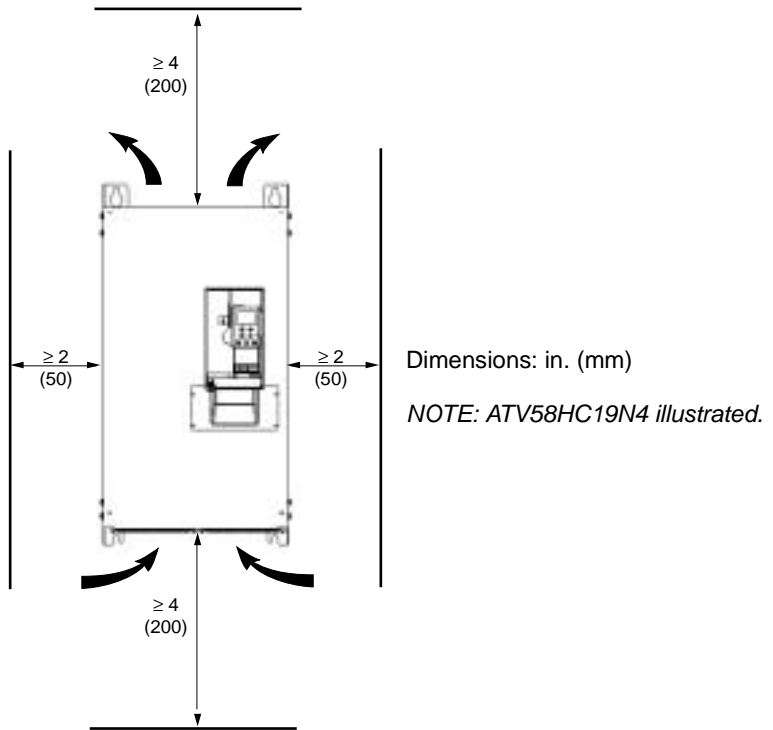

Figure 8: Minimum Clearances: ATV58HC10N4X to C33N4X

Mounting and Temperature Conditions (Refer to Figures 6–8)

ATV58HU09M2 to U72M2 and ATV58HU18N4 to U90N4:

- From -10 to 40 °C (+14 to 104 °F)
For $d \geq 2$ in. (50 mm): no special precautions.
For $d < 2$ in.: remove the protective cover from the top of the drive controller as shown in Figure 9 on page 29.
- From 40 to 50 °C (104 to 122 °F):
For $d \geq 2$ in. (50 mm): remove the protective cover from the top of the drive controller as shown in Figure 9.
For $d < 2$ in. (50 mm): add the control ventilation kit VW3A5882• (see catalog 8806CT9801).

- From 50 to 60 °C (122 to 140 °F):
For $d \geq 2$ in. (50 mm): add the ventilation fan. See Appendix A for a list of accessories. Derate the current used by 2.2% per °C above 50 °C.

ATV58HU90M2 to D46M2 and ATV58HD12N4 to D79N4:

- From -10 to 40 °C (+14 to 104 °F):
For $d \geq 2$ in. (50 mm): no special precautions.
For $d < 2$ in. (50 mm): remove the protective cover from the top of the drive controller as shown in Figure 9.
- From 40 to 50 °C (104 to 122 °F):
For $d \geq 2$ in. (50 mm): remove the protective cover from the top of the drive controller as shown in Figure 9. Derate the current used by 2.2% per °C above 40 °C.
For $d < 2$ in. (50 mm): add the ventilation fan. See Appendix A for a list of accessories. Derate the current used by 2.2% per °C above 40 °C.

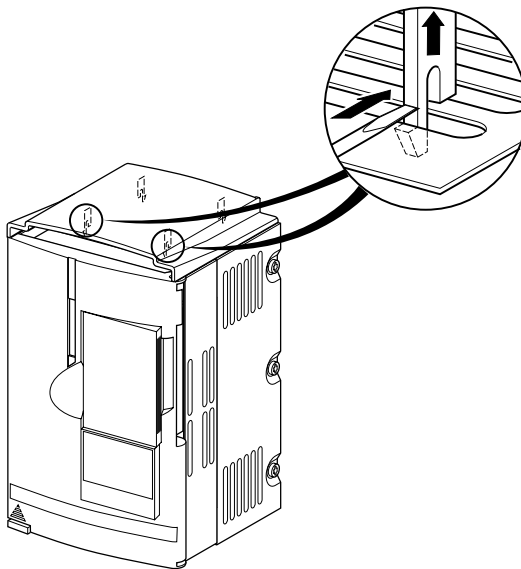

Figure 9: Removing The Protective Cover

MOUNTING IN A GENERAL PURPOSE METAL ENCLOSURE

Follow the installation precautions given on pages 26 to 29.

To ensure sufficient air circulation in the drive controller:

- Provide ventilation inlets and outlets in the enclosure as shown in Figure 10.
- If the enclosure does not provide sufficient free air flow, an enclosure ventilation fan is required to exhaust the heat outside of the enclosure. The enclosure fan should have a greater fan flow rate than the drive controller fan flow rate listed in.
- Dust filters should be used if a ventilation fan is required.

If there is a possibility of condensation, keep the control supply switched on during periods when the motor is not running, or install thermostatically controlled strip heaters.

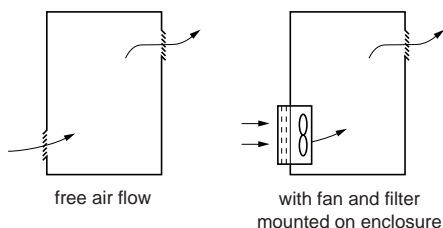

Figure 10: Ventilation for General Purpose Enclosures

Table 18: ATV58 TRX Fan Flow Rates

Drive Controller ATV58H•••••	Fan Flow Rate	
	Non-ventilated	
U09M2, U18M2		
U29M2, U18N4, U29N4, U41N4, U54N4	36 m ³ /hour	21 CFM
U41M2	47 m ³ /hour	27.5 CFM
U54M2, U72M2, U54N4, U72N4, U90N4	72 m ³ /hour	42 CFM
U90M2, D12M2, D12N4, D16N4, D23N4	72 m ³ /hour	42 CFM
D16M2, D23M2, D28N4, D33N4, D46N4	161 m ³ /hour	94 CFM
D28M2, D33M2, D46M2, D54N4, D64N4, D79N4	343 m ³ /hour	200 CFM
C10N4X	600 m ³ /hour	350 CFM
C13N4X, C15N4X, C19N4X	900 m ³ /hour	525 CFM
C23N4X, C25N4X, C28N4X, C31N4X, C33N4X	900 m ³ /hour	525 CFM

MOUNTING IN A TYPE 12 OR IP54 METAL ENCLOSURE

Certain conditions such as dust, corrosive gas, high humidity with the risk of condensation, and dripping water may require Type 12 or IP54 protection.

When mounting the controller in a Type 12 or IP54 enclosure, follow the installation precautions on pages 26–29.

To prevent hot spots in the drive controller if it is non-ventilated, use a stirring fan to circulate the air inside the enclosure. With a stirring fan, the maximum allowable temperature inside the enclosure is 60 °C. Derate the current used by 2.2% per °C above 50 °C for ATV58HU09M2–U72M2 and ATV58HU18N4–U90N4. Derate current used by 2.2% per °C above 40 °C for ATV58HU90M2–D46M2 and ATV58HD12N4–D79N4. If there is the possibility of condensation, keep the power supply switched on during periods when the motor is not running, or install thermostatically controlled strip heaters.

Calculating Enclosure Size

The equation for calculating Rth (°C/W), the maximum allowable thermal resistance of the enclosure, is:

$$R_{th} = \frac{T_i - T_o}{P}$$

T_i = Max. internal ambient temp. (°C) around drive controller
 T_o = Max. external temp. (°C) around enclosure
 P = Total power dissipated in enclosure (W)

Useful heat exchange surface area, S (in²), of a wall-mounted enclosure generally consists of the sides, top, and front. The minimum surface area required for a drive controller enclosure is calculated as follows.

NOTE: Contact the enclosure manufacturer for K factors.

$$S = \frac{K}{R_{th}}$$

R_{th} = Thermal resistance of the enclosure (calculated above)
 K = Thermal resistance per square inch of the enclosure.

Consider the following points when sizing the enclosure:

- Use only metallic enclosures, since they have good thermal conduction.
- This procedure does not take into account radiant or convected heat from external sources. Do not install enclosures where external heat sources (such as direct sunlight) can add to the enclosure heat load.
- If additional devices are present inside the enclosure, factor the heat load of the devices into the calculation.
- The actual useful area for convection cooling of the enclosure will vary depending upon the method of mounting. The method of mounting must allow for free air movement over all surfaces considered for convection cooling.

Example

The following example illustrates calculation of the enclosure size for an ATV58HU29N4 (2 hp) drive controller mounted in a Type 12 enclosure.

- Maximum external temperature: $T_o = 25\text{ }^\circ\text{C}$
- Power dissipated inside enclosure: $P = 97\text{ W}$ (from Table 7)
- Maximum internal temperature: $T_i = 40\text{ }^\circ\text{C}$
- Thermal resistance per square inch of enclosure: $K = 186$
- Calculate maximum allowable thermal resistance, R_{th} :

$$R_{th} = \frac{40\text{ }^\circ\text{C} - 25\text{ }^\circ\text{C}}{97\text{ W}} = 0.16\text{ }^\circ\text{C/W}$$

- Calculate minimum useful heat exchange surface area, S :

$$S = \frac{186}{0.16} = 1162.5\text{ in}^2$$

Useful heat exchange surface area (S) of the proposed wall-mounted enclosure:

- Height: 24 in (610 mm)
- Width: 20 in (508 mm)
- Depth: 12 in (305 mm)

$$S = \begin{matrix} \text{front area} & \text{top area} & \text{side area} \\ \downarrow & \downarrow & \downarrow \\ (24 \times 20) & + (20 \times 12) & + 2(24 \times 12) \end{matrix} = 1296\text{ in}^2$$

If the selected enclosure does not provide the required surface area or does not meet the application needs, consider the following:

- Use a larger enclosure.
- Add a passive heat exchanger to the enclosure.
- Add an air conditioning unit to the enclosure.

ELECTROMAGNETIC COMPATIBILITY (EMC)

The ATV58 *TRX* drive controller is considered to be a component. It is neither a machine nor a piece of equipment ready for use in accordance with the European Community directives (machinery directive or electromagnetic compatibility directive). It is the user's responsibility to ensure that the machine meets these standards.

A metal EMC plate is available for ATV58 *TRX* drive controllers to assist in meeting the European Community EMC directives. This kit is for integrators and end users who are including the drive controller as part of a machine to be exported to Europe requiring compliance to these directives.

See Appendix A for a list of accessories. Instruction bulletin no. 30072-450-04 ships with the EMC plate kit and contains information about its use.

ATV58 *TRX* drive controllers are marked with the CE European Community mark.

WIRING

⚠ DANGER

HAZARDOUS VOLTAGE
Turn off all power supplying this equipment before working on it.
Failure to observe this instruction will result in death or serious injury.

Before wiring the drive controller, first perform the bus voltage measurement procedure on page 42. Figures 11–18 show the location of the terminal strips.

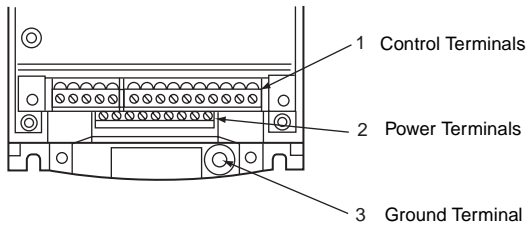

Figure 11: Terminal Locations (Product Frame Size 1)

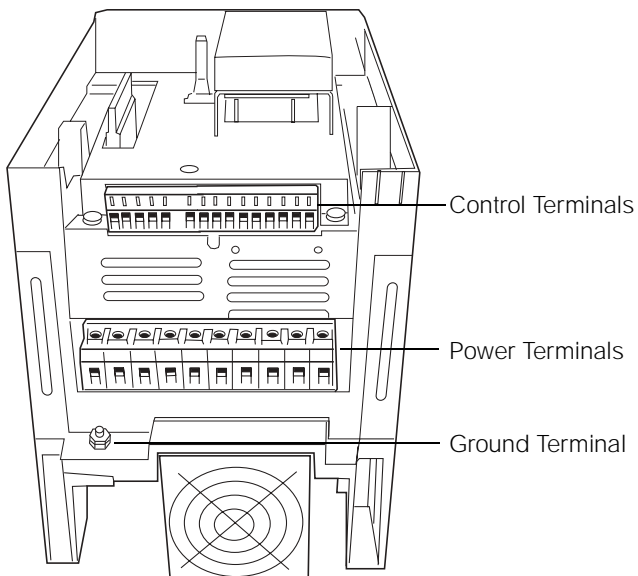

Figure 12: Terminal Locations (Product Frame Sizes 2 and 3)

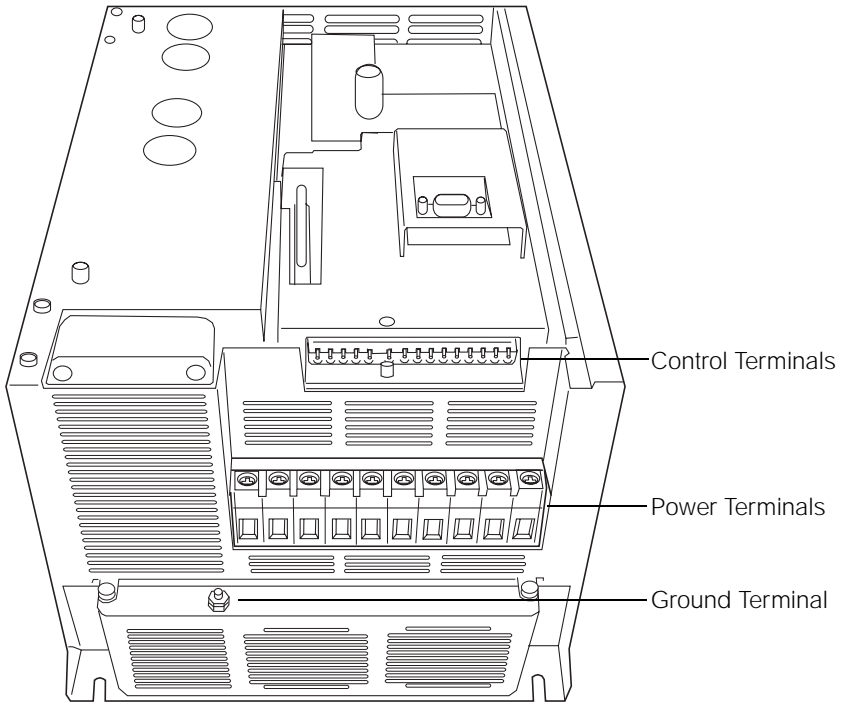

Figure 13: Terminal Locations (Product Frame Sizes 4 and 5)

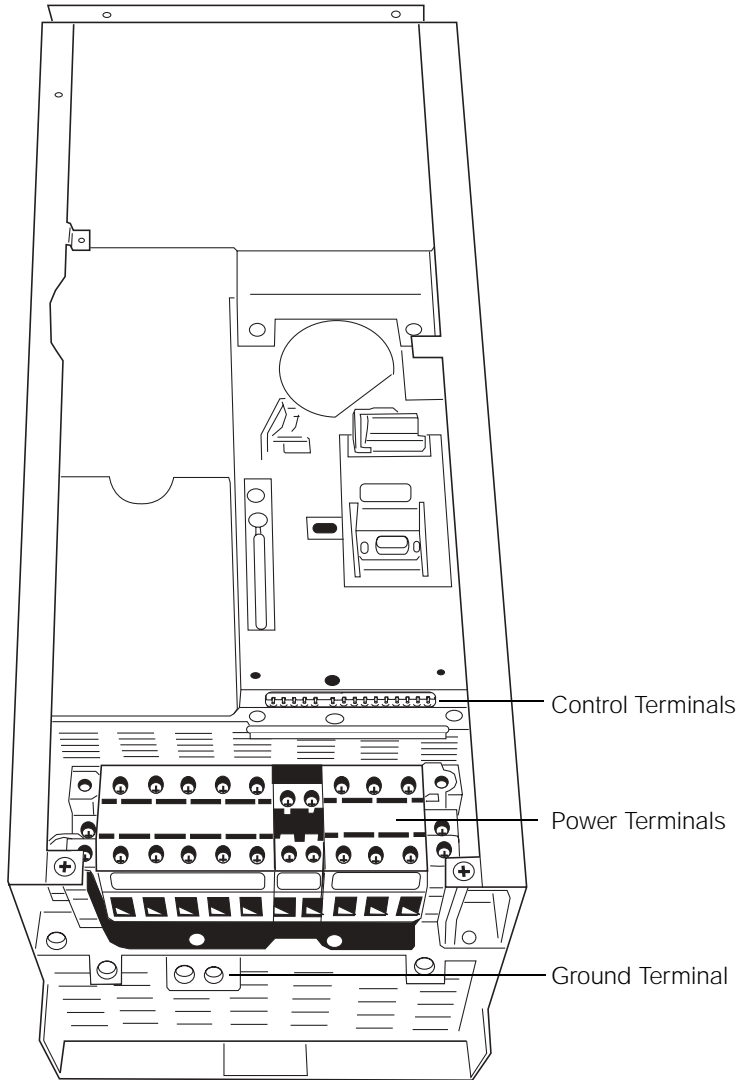

Figure 14: Terminal Locations (Product Frame Size 6)

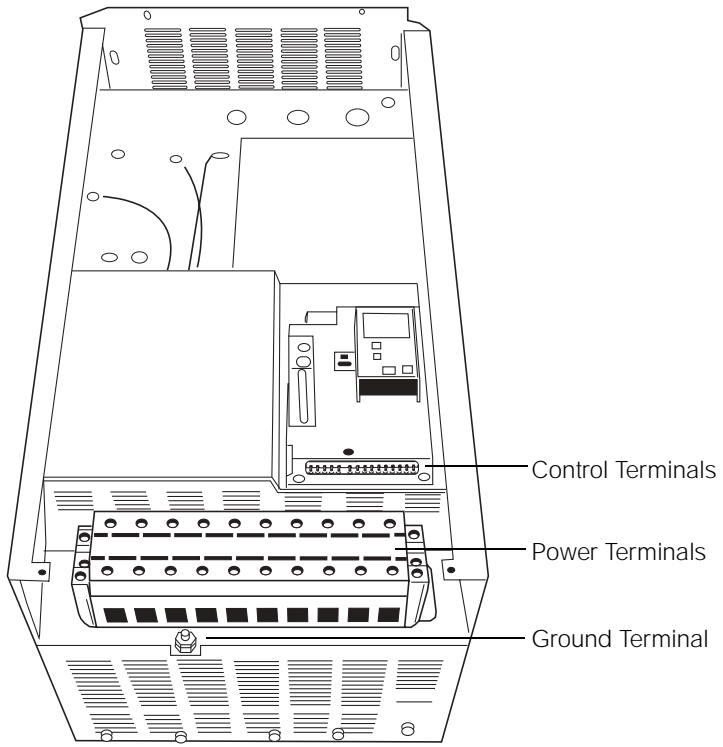

Figure 15: Terminal Locations (Product Frame Size 7)

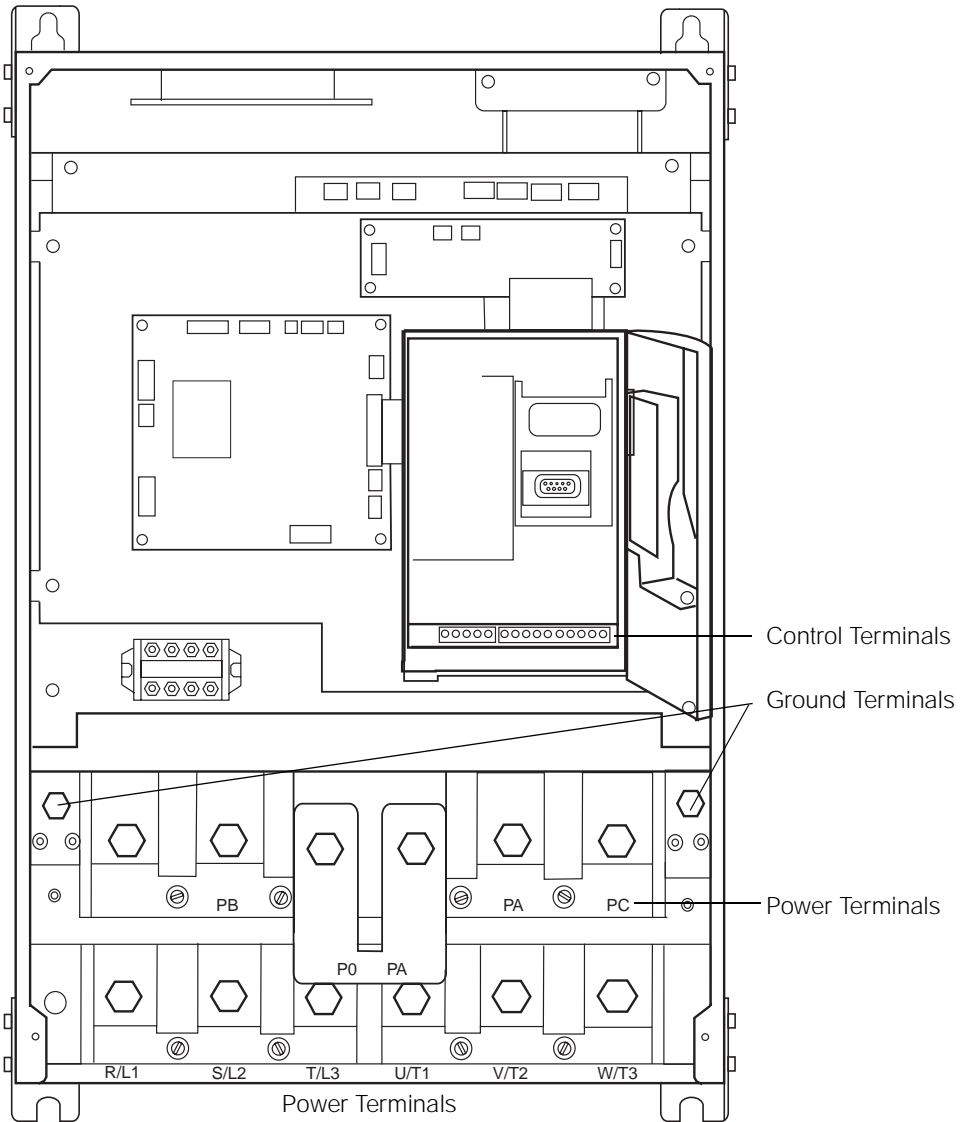

Figure 16: Terminal Locations (Product Frame Size 8)

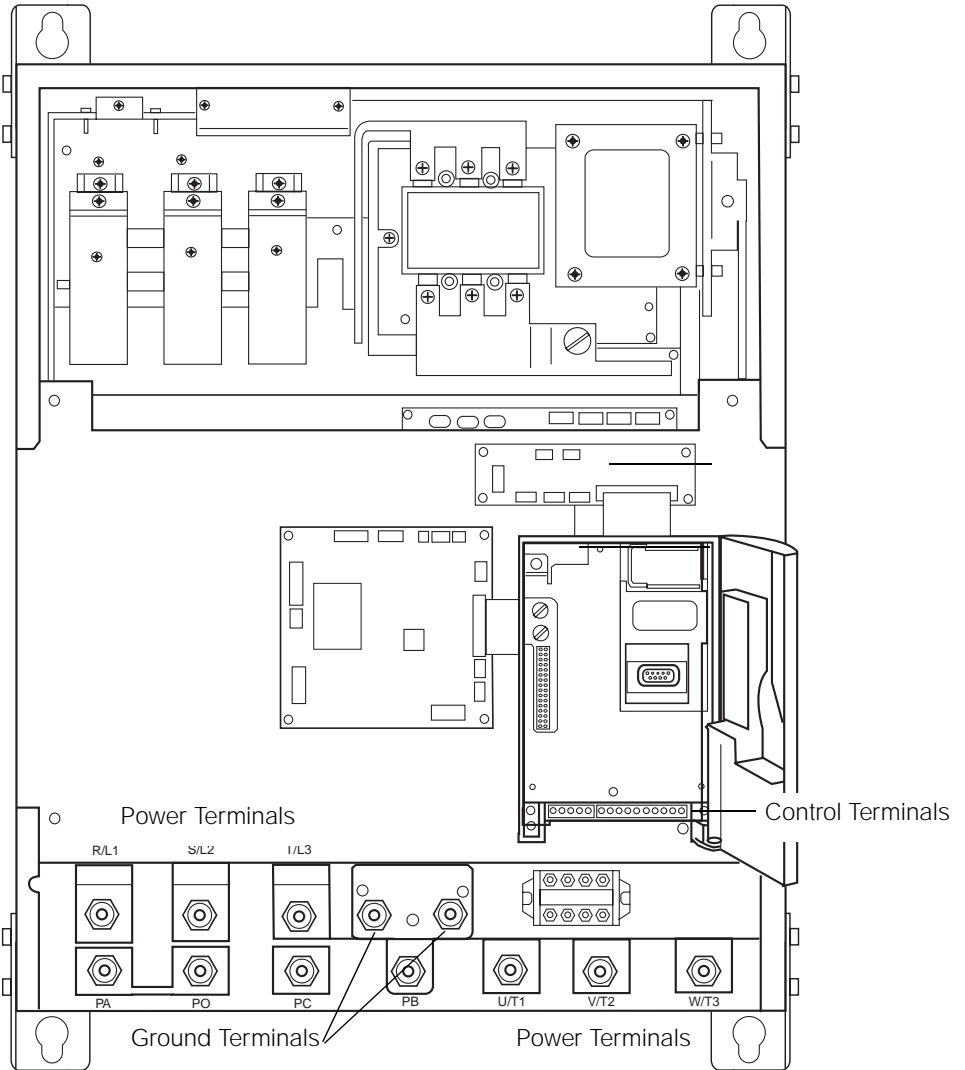

Figure 17: Terminal Locations (Product Frame Size 9)

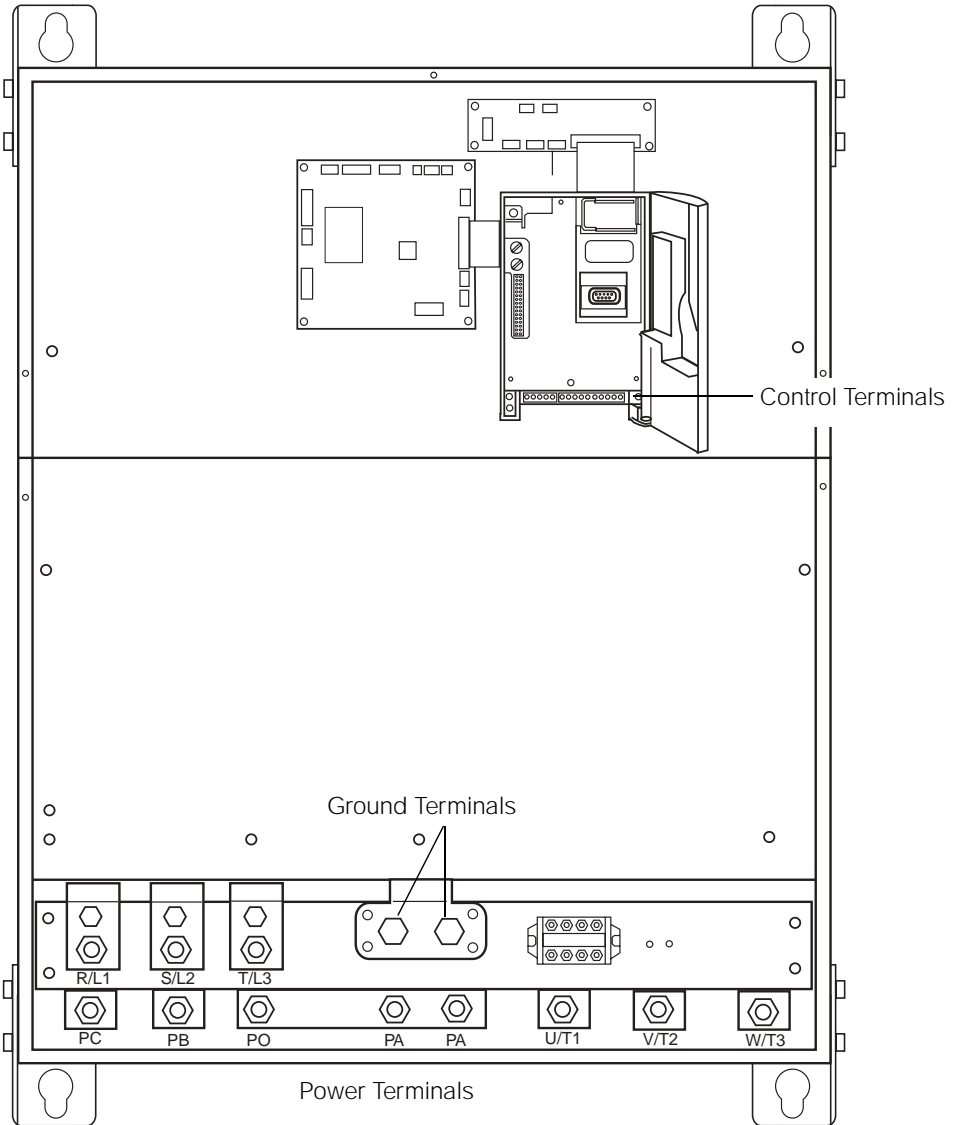

Figure 18: Terminal Locations (Product Frame Size 10)

Bus Voltage Measurement Procedure

⚠ DANGER

HAZARDOUS VOLTAGE

- Read and understand the bus voltage measurement procedure before performing the procedure. Measurement of bus capacitor voltage must be performed by qualified personnel.
- DO NOT short across DC bus capacitors or touch unshielded components or terminal strip screw connections with voltage present.
- Many parts in this drive controller, including printed wiring boards, operate at line voltage. DO NOT TOUCH. Use only electrically insulated tools.

Electrical shock will result in death or serious injury.

The DC bus voltage level is determined by monitoring the (+) and (–) measurement points. Their location varies by drive controller model number as listed in Table 19 and shown in Figure 19 on page 44. The drive controller model number is listed on its nameplate.

Table 19: (+) and (–) Measurement Points

Drive Controller ATV58H•••••	(+) Measurement Point		(–) Measurement Point	
	Terminal Block or Connector	Terminal Designation	Terminal Block or Connector	Terminal Designation
U09M2• and U18M2•	J2	(+)	J2	(–)
U29M2• to D12M2• U18N4• to D23N4•	J2	PA	J18	7
D16M2• to D46M2• D28N4• to D79N4•	J2	(+)	J2	(–)
C13N4X to C33N4X		PA (+)		PC (–)

To measure the DC bus capacitor voltage:

1. Disconnect all power from the drive controller including external control power that may be present on the control board and the option board terminals.
2. Wait ten minutes for the DC bus capacitors to discharge.
3. Read the model number of the drive controller from the nameplate and identify the corresponding (+) and (–) measurement points from Table 19 and Figure 19.
4. Open the door or cover of the drive controller.
5. Set the voltmeter to the 1000 Vdc scale. Measure the voltage between the (+) and (–) measurement points identified in step 3. Verify that the DC bus voltage has discharged below 45 V before servicing the drive controller.
6. If the DC bus capacitors will not discharge below 45 V, contact your local Square D representative. **Do not operate the drive controller.**
7. Replace all of the covers after servicing the drive controller.

The J18 connector is in the upper left hand corner of the main control board behind the flexible shield. Use a thin probe to access the connector pin.

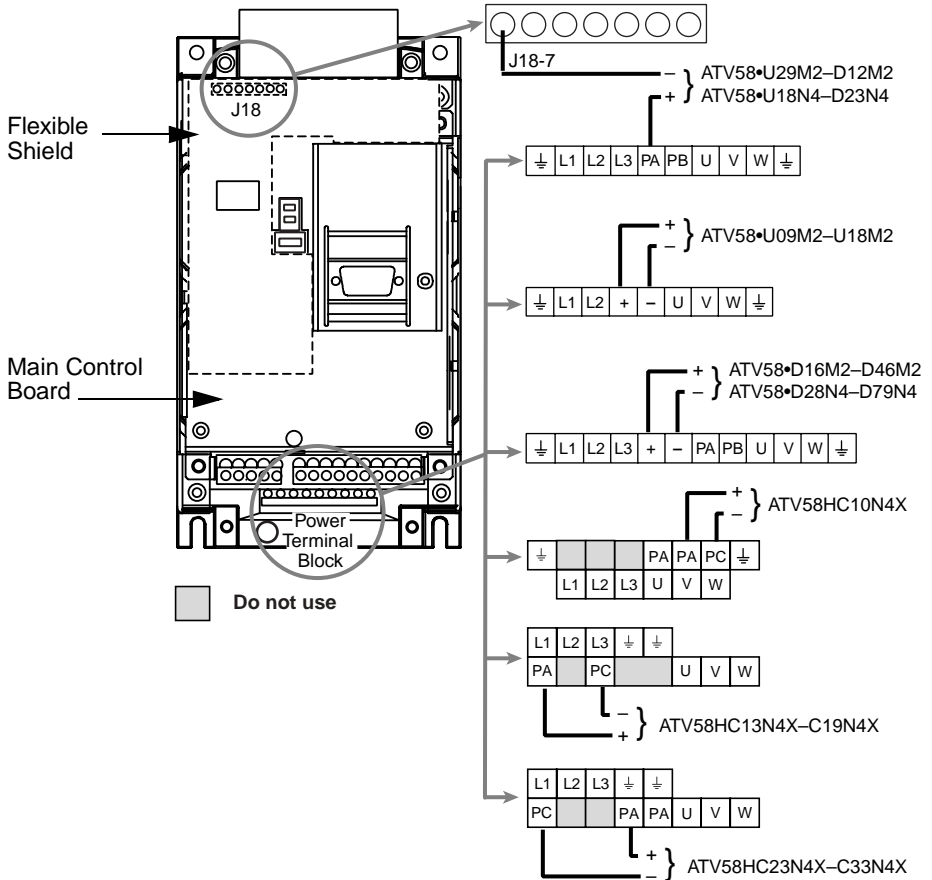

Figure 19: DC Bus Measurement Terminals

General Wiring Practices

Good wiring practice requires the separation of control wiring from power wiring. Power wiring to the motor must have the maximum possible separation from all other power wiring, whether from the same drive controller or other drive controllers. **Do not run power and control wiring, or multiple power wiring in the same conduit.** This separation reduces the possibility of coupling electrical transients from power circuits into control circuits or from motor power wiring into other power circuits.

CAUTION

IMPROPER WIRING PRACTICES

Follow the wiring practices described in this document in addition to those already required by the National Electrical Code and local electrical codes.

Failure to follow this instruction can result in injury or equipment damage.

Follow the practices below when wiring ATV58 TRX drive controllers:

- When using metallic conduit, use metal conduit kits. See Appendix A for a list of the conduit kits.
- Use metallic conduit for all drive controller wiring. Do not run control and power wiring in the same conduit.
- Separate metallic conduits carrying power wiring or low-level control wiring by at least 3 in. (76 mm).
- Separate non-metallic conduits or cable trays used to carry power wiring from metallic conduit carrying low-level control wiring by at least 12 in. (305 mm).
- Always cross power and control wiring at right angles.
- Equip all inductive circuits near the drive (such as relays, contactors, and solenoid valves) with noise suppressors or connect them to a separate circuit.

Branch Circuit Connections

Refer to NEC Article 430 for sizing the branch circuit conductors. All branch circuit components and equipment (such as transformers, feeder cables, disconnect devices, and protective devices) must be rated for the input line current of the ATV58 TRX drive controller, or the rated output current, whichever value is larger. The input line current of the controller depends on the impedance of the power distribution system and the available fault current at the drive controller input terminals.

Select the input current corresponding to the available fault current capability or the line impedance present. If the branch circuit available fault current capability is limited by fuses or circuit breakers (not system impedance), use the available fault current capability on the line side of the fuses or circuit breakers to select the drive controller input current. The input current values for the variable torque drive controller ratings are based on nominal NEC rated motor currents. The input current values for the constant torque drive controller ratings are based on drive controller rated output currents. Tables 20–29 on pages 47–55 provide input current information to optimally size branch circuit conductors.

NOTE: The branch circuit feeder protection rating should not be less than the rated output current of the drive controller.

WARNING

IMPROPER OVERCURRENT COORDINATION

- Protective devices must be properly coordinated.
- The National Electrical Code requires branch circuit protection. Use the fuses recommended in Tables 34–36 on pages 66–68 of this manual to achieve published fault withstand current ratings.
- Do not connect the drive controller to a power feeder whose short circuit capacity exceeds the drive controller withstand fault rating listed on the drive controller nameplate or Tables 20 to 29 (pages 47 to 55).

Failure to follow this instruction can result in death, serious injury, or equipment damage.

Table 20: Input Line Currents, Constant Torque, 208/230 V Ratings, Single-Phase Input • Three-Phase Output, Switching Frequency @ 4 kHz

NOTE: The input conductor ampacity rating should not be less than the ampacity rating selected based on the rated controller output current.

Drive Controller Catalog Number	Motor Power 208/230 V		Rated Output Current A	Input Line Current							
				2000 AIC		5000 AIC		22000 AIC		w/ Additional 3% Line Impedance 22000 AIC	
	kW	hp		208 V A	230 V A	208 V A	230 V A	208 V A	230 V A	208 V A	230 V A
ATV58HU09M2•	0.37	0.5	2.3	5.6	4.7	—	—	—	—	4.2	3.8
ATV58HU18M2•	0.75	1	4.1	9.8	8.3	—	—	—	—	7.9	7.0
ATV58HU29M2•	1.5	2	7.8	—	—	18.5	15.6	—	—	14.1	12.3
ATV58HU41M2•	2.2	3	11	—	—	25.6	21.6	—	—	20.5	17.5
ATV58HU72M2•	3	4	13.7	—	—	25.1	22.7	—	—	23.3	20.6
ATV58HU90M2•	4	5	18.2	—	—	27.5	24.8	30.7	27.6	32.3	28.6
ATV58HD12M2•	5.5	7.5	24.2	—	—	39.8	36.6	44.9	40	42.5	37.6

Table 21: Input Line Currents, Variable Torque Low Noise, 208/230 V Ratings, Single-Phase Input • Three-Phase Output, Switching Frequency: ATV58HU09M2–D12M2 @ 8 kHz, ATV58HD16M2–D46M2 @ 4kHz

NOTE: The input conductor ampacity rating should not be less than the ampacity rating selected based on the rated controller output current.

Drive Controller Catalog Number	Motor Power 208/230 V		Rated Output Current A	Input Line Current						w/ Additional 3% Line Impedance 22000 AIC	
	kW	hp		2000 AIC		5000 AIC		22000 AIC			
				208 V A	230 V A	208 V A	230 V A	208 V A	230 V A	208 V A	230 V A
ATV58HU09M2*	0.37	0.5	2.3	5.6	4.7	—	—	—	—	4.2	3.8
ATV58HU18M2*	0.75	1	4.8	9.8	8.3	—	—	—	—	7.9	7.0
ATV58HU29M2*	1.5	2	7.8	—	—	18.5	15.6	—	—	14.1	12.3
ATV58HU41M2*	2.2	3	11	—	—	25.6	21.6	—	—	20.5	17.5
ATV58HU72M2*[1]	3	4	14.3	—	—	25.1	22.7	—	—	23.3	20.6
ATV58HU90M2*[1]	4	5	17.5	—	—	27.5	24.8	35	30	32.3	28.6
ATV58HD12M2*[1]	5.5	7.5	25.3	—	—	39.8	36.6	46	39.4	42.5	37.6
ATV58HD16M2*[1]	7.5	10	30.8	—	—	—	—	—	—	60	53
ATV58HD23M2*[1]	11	15	46.2	—	—	—	—	—	—	86	76
ATV58HD28M2*[1]	15	20	60	—	—	—	—	—	—	115	102
ATV58HD33M2*[1]	18.5	25	75	—	—	—	—	—	—	141	125
ATV58HD46M2*[1]	22	30	88	—	—	—	—	—	—	168	149

[1] A 3% line reactor must be used when supplied with single phase input

Table 22: Input Line Currents, Constant Torque, 208/230 V Ratings, Three-Phase Input • Three-Phase Output, Switching Frequency: ATV58HU29M2–D23M2 @ 4kHz, ATV58HD28M2–D46M2 @ 2 kHz

NOTE: The input conductor ampacity rating should not be less than the ampacity rating selected based on the rated controller output current.

Drive Controller Catalog Number	Motor Power 208/230 V		Rated Output Current A	Input Line Current						w/ Additional 3% Line Impedance 22000 AIC	
				5000 AIC		10000 AIC		22000 AIC			
				208 V A	230 V A	208 V A	230 V A	208 V A	230 V A		
ATV58HU29M2•	1.5	2	7.8	9.7	8.3	—	—	—	—	6.6	5.9
ATV58HU41M2•	2.2	3	11	13.4	11.4	—	—	—	—	9.5	8.5
ATV58HU54M2•	3	4	13.7	17.2	15	—	—	—	—	12.6	11.2
ATV58HU72M2•	4	5	18.2	22.4	19.5	—	—	—	—	16.9	14.6
ATV58HU90M2	5.5	7.5	24.2	30	26.4	32.1	28.4	34.7	30	23.3	20.6
ATV58HD12M2•	7.5	10	31	39.7	35	42.3	37.4	44.4	38.2	32.3	28.6
ATV58HD16M2•	11	15	47	42.4	43.1	42.8	43.3	43.4	43.6	43.4	43.0
ATV58HD23M2•	15	20	60	58	58.5	58.2	58.3	58.5	58.7	58.5	58.7
ATV58HD28M2•	18.5	25	75	70.2	70.4	70.6	70.4	70.2	70.4	69.4	70.0
ATV58HD33M2•	22	30	88	82.3	82.7	82.5	83.9	84.0	84.0	83.2	83.6
ATV58HD46M2•	30	40	116	100.8	102.2	101.2	103.2	101.7	101.5	101.7	103.7

Table 23: Input Line Currents, Constant Torque Low Noise, 208/230 V Ratings, Three-Phase Input • Three-Phase Output, Switching Frequency: ATV58HD16M2–D23M2 @ 8 kHz, ATV58HD28M2–D46M2 @ 4 kHz

NOTE: The input conductor ampacity rating should not be less than the ampacity rating selected based on the rated controller output current.

Drive Controller Catalog Number	Motor Power 208/230 V		Rated Output Current A	Input Line Current						w/ Additional 3% Line Impedance	
				5000 AIC		10000 AIC		22000 AIC			
				208 V A	230 V A	208 V A	230 V A	208 V A	230 V A		
ATV58HD16M2•	7.5	10	31	36.2	37.1	36.5	37.2	36.8	37.2	36.7	37.3
ATV58HD23M2•	11	15	47	43.2	43.5	43.3	43.9	44.0	44.5	43.3	43.8
ATV58HD28M2•	15	20	60	58.3	58.9	58.3	59.3	58.6	59.3	58.3	58.8
ATV58HD33M2•	18.5	25	75	71.0	71.7	71.3	72.5	72.6	73.5	72.6	73.4
ATV58HD46M2•	22	30	88	82.3	83.3	84.7	85.7	85.3	86.6	85.0	86.8

Table 24: Input Line Currents, Variable Torque, 208/230 V Ratings, Three-Phase Input • Three-Phase Output, Switching Frequency: ATV58HU29M2–D23M2 @ 4 kHz, ATV58HD28M2–D46M2 @ 2 kHz

NOTE: The input conductor ampacity rating should not be less than the ampacity rating selected based on the rated controller output current.

Drive Controller Catalog Number	Motor Power 208/230 V		Rated Output Current A	Input Line Current							
				5000 AIC		10000 AIC		22000 AIC		w/ Additional 3% Line Impedance	
	kW	hp		208 V A	230 V A	208 V A	230 V A	208 V A	230 V A	208 V A	230 V A
ATV58HU29M2•	1.5	2	7.5	9.4	8.6	—	—	—	—	6.6	5.9
ATV58HU41M2•	2.2	3	10.6	13	11.8	—	—	—	—	9.5	8.5
ATV58HU54M2•	3	4	14.3	17.2	15	—	—	—	—	12.6	11.2
ATV58HU72M2•	4	5	16.7	21.4	19.5	—	—	—	—	16.9	14.6
ATV58HU90M2	5.5	7.5	24.2	29	26.4	32.1	28.4	34.7	30	23.3	20.6
ATV58HD12M2•	7.5	10	30.8	38.3	35	42.3	37.4	44.4	38.2	32.3	28.6
ATV58HD16M2•	11	15	46.2	41.7	37.8	41.7	38.0	41.7	38.0	41.7	38.0
ATV58HD16M2•	15	20	60	55.5	50.5	55.7	50.5	55.7	50.8	55.1	50.5
ATV58HD23M2•	18.5	25	75	67.0	61.8	67.2	61.8	67.2	61.8	67.1	61.4
ATV58HD28M2•	22	30	88	80.5	73.3	80.6	73.3	80.9	73.6	80.7	73.6
ATV58HD33M2•	30	40	116	107.6	97.9	108.4	97.9	108.4	98.5	107.6	98.5
ATV58HD46M2•	37	50	143	134.8	121.2	135.4	121.2	135.5	124.0	135.0	123.7

Table 25: Input Line Currents, Variable Torque Low Noise, 208/230 V Ratings, Three-Phase Input • Three-Phase Output, Switching Frequency: ATV58HU29M2–D23M2 @ 8 kHz, ATV58HD28M2–D46M2 @ 4 kHz

NOTE: The input conductor ampacity rating should not be less than the ampacity rating selected based on the rated controller output current.

Drive Controller Catalog Number	Motor Power 208/230 V		Rated Output Current A	Input Line Current							
				5000 AIC		10000 AIC		22000 AIC		w/ Additional 3% Line Impedance	
	kW	hp		208V A	230 V A	208 V A	230 V A	208 V A	230 V A	208 V A	230 V A
ATV58HU29M2•	1.5	2	7.5	9.4	8.6	—	—	—	—	6.6	5.9
ATV58HU41M2•	2.2	3	10.6	13	11.8	—	—	—	—	9.5	8.5
ATV58HU54M2•	3	4	14.3	17.2	15	—	—	—	—	12.6	11.2
ATV58HU72M2•	4	5	16.7	21.4	19.5	—	—	—	—	16.9	14.6
ATV58HU90M2	5.5	7.5	24.2	29	26.4	32.1	28.4	34.7	30	23.3	20.7
ATV58HD12M2•	7.5	10	30.8	38.3	35	35.7	32.4	35.8	32.8	35.2	32.8
ATV58HD16M2•	11	15	46.2	42.7	39.0	42.7	39.0	42.7	39.0	42.4	39.0
ATV58HD23M2•	15	20	60	55.2	48.9	55.2	50.5	55.4	51.2	55.4	50.7
ATV58HD28M2•	18.5	25	75	67.8	61.9	68.2	62.1	68.4	62.6	67.6	61.6
ATV58HD33M2•	22	30	88	82.0	73.8	82.0	75.1	82.8	76.7	82.8	76.5
ATV58HD46M2•	30	40	116	108.6	97.3	109.2	99.2	109.7	99.7	109.4	99.7

Table 26: Input Line Currents, Constant Torque, 400/460 V Ratings, Three-Phase Input • Three-Phase Output, Switching Frequency: ATV58HU18N4–D46N4 @ 4 kHz, ATV58HD54N4–D79N4 @ 2 kHz

NOTE: The input conductor ampacity rating should not be less than the ampacity rating selected based on the rated controller output current.

Drive Controller Catalog Number	Motor Power		Rated Output Current A	Input Line Current							
				5000 AIC		10000 AIC		22000 AIC		w/ Additional 3% Line Impedance	
	400 V kW	460 V hp		400 V A	460 V A	400 V A	460 V A	400 V A	460 V A	400 V A	460 V A
ATV58HU18N4*	0.75	1	2.3	3.4	2.6	—	—	—	—	1.9	1.6
ATV58HU29N4*	1.5	2	4.1	6.0	4.5	—	—	—	—	3.3	3.0
ATV58HU41N4*	2.2	3	5.8	7.8	6	—	—	—	—	4.8	4.2
ATV58HU54N4*	3	4	7.8	10.2	7.8	—	—	—	—	6.3	5.6
ATV58HU72N4*	4	5	10.5	13.0	10.1	—	—	—	—	8.6	7.2
ATV58HU90N4*	5.5	7.5	13	17.0	13.2	—	—	—	—	11.8	10.1
ATV58HD12N4*	7.5	10	17.6	20.7	18.2	22.7	19.9	26.5	21	16	13.2
ATV58HD16N4*	11	15	24.2	28.8	25.3	31.4	27.6	35.4	28	23.6	19.5
ATV58HD23N4*	15	20	33	36.5	32	39.6	34.7	44.7	35.6	30.6	25.8
ATV58HD28N4*	18.5	25	40.7	37.3	38.3	37.9	39.2	38.9	40.1	38.7	40.0
ATV58HD33N4*	22	30	48.4	44.4	44.8	45.9	46.7	46.5	47.6	46.4	47.6
ATV58HD46N4*	30	40	66	59.1	59.9	61.2	61.9	62.0	61.9	62.1	63.7
ATV58HD54N4*	37	50	79.2	70.6	71.4	73.3	74.7	74.7	74.7	74.9	76.3
ATV58HD64N4*	45	60	93.5	84.3	84.8	88.8	89.7	92.3	89.7	92.3	93.8
ATV58HD79N4*	55	75	115.5	102.7	103.3	106.4	108.6	111.6	108.6	112.1	112.7

Table 27: Input Line Currents, Constant Torque Low Noise, 400/460 V Ratings, Three-Phase Input • Three-Phase Output, Switching Frequency: ATV58HD28N4–D46N4 @ 8 kHz, ATV58HD54N4–D79N4 @ 4 kHz

NOTE: The input conductor ampacity rating should not be less than the ampacity rating selected based on the rated controller output current.

Drive Controller Catalog Number	Motor Power		Rated Output Current A	Input Line Current							
				5000 AIC		10000 AIC		22000 AIC		w/ Additional 3% Line Impedance 22000 AIC	
	400 V kW	460 V hp		400 V A	460 V A	400 V A	460 V A	400 V A	460 V A	400 V A	460 V A
ATV58HD28N4*	15	20	33	31.7	32.4	32.4	33.1	33.1	33.7	33.0	33.6
ATV58HD33N4*	18.5	25	40.7	37.9	39.3	39.4	40.1	40.4	40.7	40.3	41.0
ATV58HD46N4*	22	30	48.4	46.3	47.0	48.2	48.7	49.0	49.8	49.1	49.4
ATV58HD54N4*	30	40	66	60.9	60.4	63.2	63.0	64.4	65.4	64.7	64.8
ATV58HD64N4*	37	50	79.2	73.0	74.3	77.9	78.8	80.2	82.1	81.0	81.7
ATV58HD79N4*	45	60	93.5	65.3	65.8	90.6	91.7	94.6	95.0	94.4	94.9

Table 28: Input Line Currents, Variable Torque, 400/460 V Ratings, Three-Phase Input • Three-Phase Output, Switching Frequency: ATV58HU18N4–D23N4 @ 8 kHz, ATV58HD28N4–D46N4 @ 4kHz, ATV58HD54N4–C33N4X @ 2 kHz

NOTE: The input conductor ampacity rating should not be less than the ampacity rating selected based on the rated controller output current.

Drive Controller Catalog Number	Motor Power		Rated Output Current A	Input Line Current							
				5000 AIC		10000 AIC		22000 AIC		w/ Additional 3% Line Impedance 22000 AIC	
	400 V kW	460 V hp		400 V A	460 V A	400 V A	460 V A	400 V A	460 V A	400 V A	460 V A
ATV58HU18N4*	0.75	1	2.1	3.2	2.8	—	—	—	—	1.9	1.6
ATV58HU29N4*	1.5	2	3.4	5.5	4.8	—	—	—	—	3.3	3.0
ATV58HU41N4*	2.2	3	4.8	7.4	6.5	—	—	—	—	4.8	4.2
ATV58HU54N4*	3	4	6.2	10.2	7.8	—	—	—	—	6.3	5.6
ATV58HU72N4*	4	5	7.6	12.2	10.7	—	—	—	—	8.6	7.2
ATV58HU90N4	5.5	7.5	11	16.3	14.3	—	—	—	—	11.8	10.1
ATV58HD12N4*	7.5	10	14	20.7	18.2	22.7	19.9	26.5	21	16.0	13.2
ATV58HD16N4*	11	15	21	28.8	25.3	31.4	27.6	35.4	28	23.6	19.5
ATV58HD23N4*	15	20	27	36.5	32	39.6	34.7	44.7	35.6	30.6	25.8
ATV58HD28N4* [1]	18.5	25	34	36.3	32.7	36.9	33.4	37.4	34.1	37.6	34.0
ATV58HD28N4*	22	30	40	42.3	38.1	43.0	38.7	43.9	39.8	43.6	39.6
ATV58HD33N4*	30	40	52	55.5	49.3	56.3	51.1	57.1	51.6	56.8	51.4
ATV58HD46N4*	37	50	65	68.9	61.8	70.9	63.5	72.3	65.4	72.0	65.1
ATV58HD54N4*	45	60	77	82.7	72.3	84.1	75.2	85.5	77.7	85.5	77.5
ATV58HD64N4*	55	75	96	103.7	91.0	107.0	96.3	111.1	100.8	111.1	100.0
ATV58HD79N4*	75	100	124	133.6	117.4	138.0	122.6	142.9	129.3	142.4	128.8
ATV58HC10N4X	90	125	156	—	—	129	161	144	180	159	176
ATV58HC13N4X	110	150	180	—	—	147	184	165	206	182	202
ATV58HC15N4X	132	200	240	—	—	185	232	212	265	234	260
ATV58HC19N4X	160	250	302	—	—	—	—	260	325	288	320
ATV58HC23N4X	200	300	361	—	—	—	—	300	373	329	366
ATV58HC25N4X	220	350	414	—	—	—	—	337	422	372	413
ATV58HC28N4X	250	400	477	—	—	—	—	375	468	414	460
ATV58HC31N4X	280	450	515	—	—	—	—	415	519	458	508
ATV58HC33N4X	315	500	590	—	—	—	—	455	569	502	557

[1] The ATV58HD28N4 is rated for 8 kHz operation at 25 hp.

NOTE: Shaded items in the table indicate 30,000 AIC.

Table 29: Input Line Currents, Variable Torque Low Noise, 400/460 V Ratings, Three-Phase Input • Three-Phase Output: Switching Frequency: ATV58HU18N4–D46N4 @ 8 kHz, ATV58HD54N4–D79N4 @ 4 kHz

NOTE: The input conductor ampacity rating should not be less than the ampacity rating selected based on the rated controller output current.

Drive Controller Catalog Number	Motor Power		Rated Output Current A	Input Line Current								w/ Additional 3% Line Impedance 22000 AIC	
				5000 AIC		10000 AIC		22000 AIC					
	400 V kW	460 V Hp		400 V A	460 V A	400 V A	460 V A	400 V A	460 V A	400 V A	460 V A		
ATV58HU18N4*	0.75	1	2.1	3.2	2.8	—	—	—	—	1.9	1.6		
ATV58HU29N4*	1.5	2	3.4	5.5	4.8	—	—	—	—	3.3	3.0		
ATV58HU41N4*	2.2	3	4.8	7.4	6.5	—	—	—	—	4.8	4.2		
ATV58HU54N4X*	[1]	5	7.6	—	10.0	—	—	—	—	—	7.5		
ATV58HU72N4X*	[1]	7.5	11	—	14.3	—	—	—	—	—	9.9		
ATV58HU90N4X*	[1]	10	14	—	18.1	—	—	—	—	—	13.1		
ATV58HD12N4X*	[1]	15	21	—	25.8	—	—	—	—	—	19.6		
ATV58HD16N4X*	[1]	20	27	—	32.4	—	—	—	—	—	25.9		
ATV58HD23N4X*	[1]	25	34	—	38.9	—	—	—	—	—	31.1		
ATV58HD28N4*	18.5	25	34	36.3	32.7	36.9	33.4	37.4	34.1	37.6	34.0		
ATV58HD33N4*	22	30	40	43.3	39.0	44.2	40.1	45.1	40.4	44.7	40.4		
ATV58HD46N4*	30	40	52	56.9	51.0	58.5	52.8	60.3	54.5	60.2	54.3		
ATV58HD54N4*	37	50	65	70.2	61.5	71.9	64.9	73.6	67.0	73.4	67.0		
ATV58HD64N4*	45	60	77	84.0	74.4	88.8	79.8	91.8	82.8	91.8	82.5		
ATV58HD79N4*	55	75	96	102.8	91.7	106.9	96.4	112.6	100.5	112.3	100.0		

[1] This product is for 460 Vac applications at 5000 AIC. A line reactor (3% minimum) must be used at higher AIC ratings. See Table 28 for 400 Vac rated controllers in this hp range.

Output Wiring Precautions

WARNING

IMPROPER WIRING CAN CAUSE DRIVE CONTROLLER DAMAGE

The drive controller will be damaged if input line voltage is applied to output terminals (U, V, W). Check power connections before energizing the drive controller.

Failure to follow this instruction can result in death, serious injury, or equipment damage.

The drive controller is sensitive to the amount of capacitance (either phase-to-phase or phase-to-ground) present on the output power conductors. If excessive capacitance is present, the drive controller may trip on overcurrent. Follow the guidelines below when selecting output cable:

- Cable type: select cable with a low capacitance phase-to-phase and to phase-to-ground. Do not use mineral-impregnated cable because it has a very high capacitance. Immersion of cables in water increases capacitance.
- Cable length: the longer the cable, the greater the capacitance. Cable lengths greater than 100 ft (30.5 m) may cause ground faults. For installation where cable capacitances may be a problem, installing a reactor between the drive controller and the motor will increase inductance and decrease capacitance between cable conductors.
- Proximity to other output cables: because of high frequency switching and increased capacitance, the drive controller may fault under some conditions.
- **Do not use lightning arrestors or power factor correction capacitors on output of the drive controller.**

Wiring needs a minimum inductance to protect the drive controller output from short circuits. Provide at least 20 in. (500 mm) of cable at the drive controller output (U, V, W).

⚠ CAUTION

INSUFFICIENT OUTPUT INDUCTANCE

For proper drive controller short circuit protection, certain values of inductance may be required in the output power wiring. Inductance can be supplied by the power wiring or auxiliary inductors.

Failure to follow this instruction can result in injury or equipment damage.

Grounding

For safe, dependable operation, ground the drive controller according to the National Electrical Code and all local codes. To ground the drive controller:

- Connect a copper wire from the ground terminal on the drive controller (see Figures 11–18 on pages 34–41) to the power system ground conductor. Wire size is determined by the drive controller size and by national and local codes.
- Verify that the resistance to ground is one ohm or less. Improper grounding causes intermittent and unreliable operation.

⚠ DANGER

HAZARDOUS VOLTAGE

Ground the equipment using the provided ground connecting point as shown in Figures 11–18 on pages 34–41. The drive controller panel must be properly grounded before power is applied.

Do not use metallic conduit as a ground conductor.

Electrical shock will result in death or serious injury.

Ground multiple drive controllers as shown in Figure 20 on page 58. Use one grounding conductor per device. Do not loop ground conductors or install them in series.

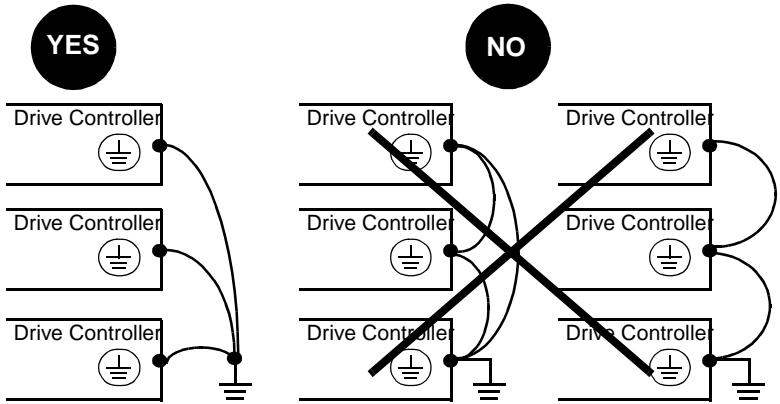

Figure 20: Grounding Multiple Drive Controllers

Power Terminals

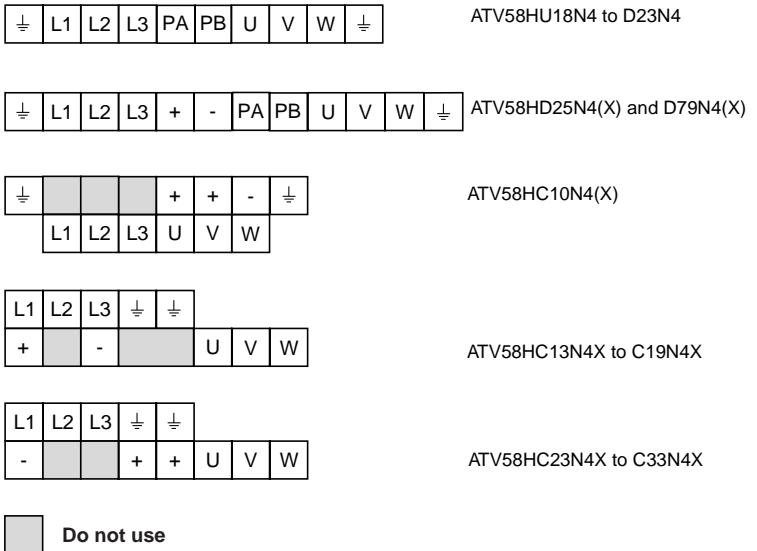

Figure 21: Power Terminal Layout

Table 30: Function of Power Terminals



Terminal	Function	For ATV58H****
	Ground terminal	All models
L1 L2	Input power	All models
L3		All models except U09M2 and U18M2
+ -	Connection for DB module	U09M2 and U18M2
PA PB	Connection for DB resistor	All models except U09M2 and U18M2
U V W	Output connections to motor	All models
	Ground terminal	All models

Table 31: Power Terminal Wire Size and Torque

Drive Controller ATV58H****	Maximum Wire Size ^[1] AWG (mm ²)	Torque lb-in (N•m)
U09M2, U18M2	14 (1.5)	5.0 (0.56)
U29M2, U41M2, U18N4, U29N4, U41N4	8 (6)	7.5 (0.85)
U54M2, U72M2, U54N4, U72N4, U90N4	8 (6)	7.5 (0.85)
U90M2, D12M2, D12N4, D16N4, D23N4	6 (10)	20 (2.26)
D16M2, D23M2, D28N4, D33N4, D46N4	2/0 (35)	88 (10)
D28M2, D33M2, D46M2, D54N4, D64N4, D79N4	4/0 (70)	170 (19)

^[1] 75 °C copper.

Power terminal lugs are shipped with drive controllers ATV58HC10N4X to ATV58HC19N4X. Supply crimp style lugs to fit the selected wire size for drive controllers ATV58HC23N4X to ATV58HC33N4X.

To install the lugs:

 DANGER

HAZARDOUS VOLTAGE

Disconnect all power before working on equipment.

Electrical shock will cause severe injury or death.

- Using the hardware provided, attach the lugs as shown in Figure 22. Note the orientation of the washers.

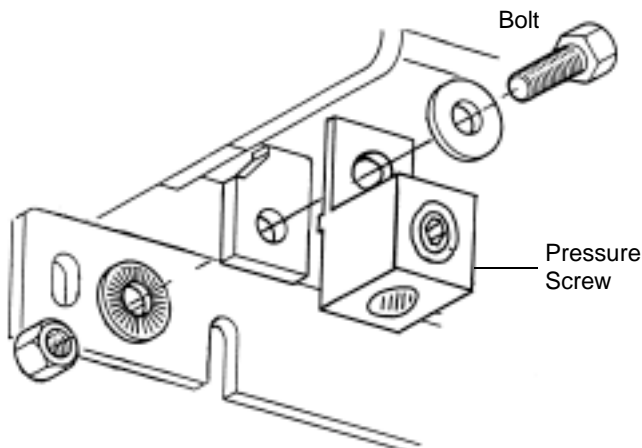

Figure 22: Lug and Washer Orientation

- Torque the bolts to the values listed in Table 32.
- Insert the power wires into the lugs and tighten the pressure screws. See the pressure screw torque requirements in Table 32.
- Check for proper electrical clearances. For applications up to 600 V, maintain at least 0.375 in. (9.53 mm) clearance between adjacent power terminal lugs and at least 0.5 in. (12.7 mm) clearance between any live part and the device enclosure.

Table 32: Lug and Pressure Screw Torque Values

Drive Controller	Bolt Torque		Wire Range MCM	Pressure Screw Torque	
	lb-in	N•m		lb-in	N•m
ATV58HC10N4X–C19N4X (6 power lugs and 2 ground lugs are supplied with these drive controllers)	310	35	4 to 500	375	42
ATV58HC23N4X–C33N4X	310	35	Supply crimp style lugs to fit selected wire size.		

Control Terminals

The control terminal strip contains two pull-apart terminal blocks, one for the relay outputs and one for the low level inputs and outputs. The S terminal is used for the shield connection. Maximum wire size for all control terminals is 14 AWG (1.5 mm²). The tightening torque is 3.5 lb-in (0.4 N•m). Figure 23 shows the location of the control terminals.

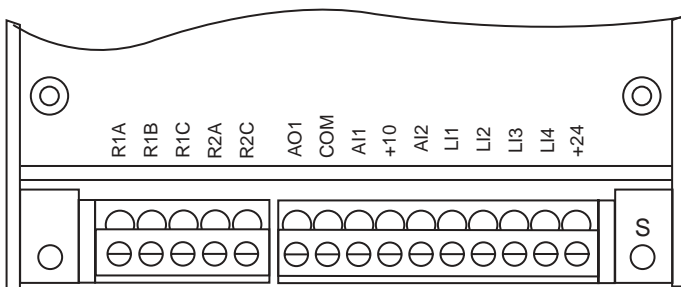

Figure 23: Location of Control Terminals

Table 33: Control Terminal Characteristics

Terminal	Function	Characteristics
S	Shield connection	
R1A R1B R1C	R1A to R1C is a N.O. contact. When the drive controller is powered with no fault, the contact is closed. R1B to R1C is a N.C. contact. When the drive controller is powered with no fault, the contact is open.	Minimum: 10 mA, 24 Vdc Maximum: inductive load of 1.5 A for 250 Vac and 30 Vdc Maximum resistive load: 5 A for 250 Vac or 30 Vdc
R2A R2C	N.O. programmable relay R2	
COM	Common for logic and analog inputs	
AO1	Analog current output X–Y mA analog output, with X and Y being programmable from 0–20 mA. Factory setting: 0–20mA	Maximum load impedance = 500 Ω Resolution: 0.04 mA (9 bits) Linearity: +/- 0.1 mA Accuracy: +/- 0.2 mA The analog output is updated every 2mS, maximum

Table 33: Control Terminal Characteristics (Continued)

Terminal	Function	Characteristics
AI1	Analog input 1 (voltage) Used for speed reference input	0 to 10 Vdc, Impedance = 30 kΩ Frequency resolution analog reference: high speed / 1024 Hz (10 bit). Accuracy ±1%, linearity ±0.5% of the maximum output frequency. Sampling time: 5 ms
+10	Supply for reference potentiometer (1 to 10 kΩ potentiometer)	10 V ± 1%, protected against short circuits and overloads 10 mA maximum
AI2	Analog input 2 (current) Used for speed reference input or feedback, depending on configuration.	X to Y mA, with X and Y being programmable from 0 to 20 mA; Factory setting: 0 to 20 mA Impedance = 100 Ω Frequency resolution analog reference: high speed / 1024 Hz (10 bit). Accuracy ±1%, linearity ±0.5% of the maximum output frequency. Sampling time: 5 ms
LI1 LI2 LI3 LI4	Logic inputs Function depends on configuration. See Table 43 on page 76 for factory settings.	Supplied by +24 Vdc State 0 if < 5 V, state 1 if > 11 V Vmax = 30 V Impedance = 3.5 kΩ Sampling time: 5 ms
+24	Power supply for logic inputs	+24 V protected against short circuits and overloads Minimum 20 V, maximum 30 V 200 mA maximum

⚠ WARNING

UNINTENDED EQUIPMENT OPERATION

LI1 has priority:

- If LI1 is closed while LI2 is active, the controller will respond to LI1.
- If the LI1 input is lost while LI2 is active, the controller will respond to LI2 and reverse directions.

The logic inputs must be programmed appropriately for the application to prevent the motor from spinning in an unintended direction.

Failure to follow this instruction can result in death or serious injury.

WIRING DIAGRAMS

Single-Phase Input

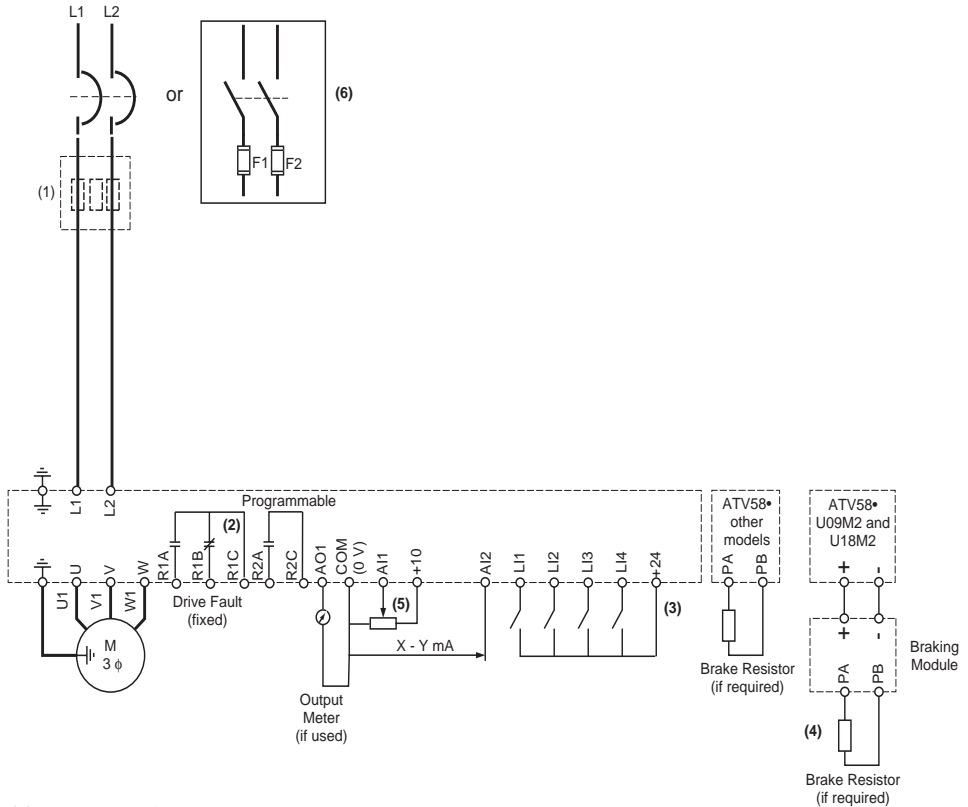

- (1) Line reactor if required.
- (2) Fault relay contacts for remote signaling of the drive controller state.
 Contact state shown with drive controller deenergized or faulted.
- (3) Internal +24 V. When using +24 V external supply, connect the 0 V to the COM terminal.
 Do not use the +24 V terminal on the control board, but connect logic inputs to external +24 V.
- (4) When using dynamic braking on drive controllers ATV58HU09M2 and U18M2, the dynamic braking module, catalog number VW3A58701, must be used. See Appendix A for available braking resistor kits.
- (5) Manual speed potentiometer (1–10 kΩ)
- (6) Branch circuit protection (circuit breaker or fuses) must be installed.

Figure 24: Single-Phase Wiring Diagram

Three-Phase Input

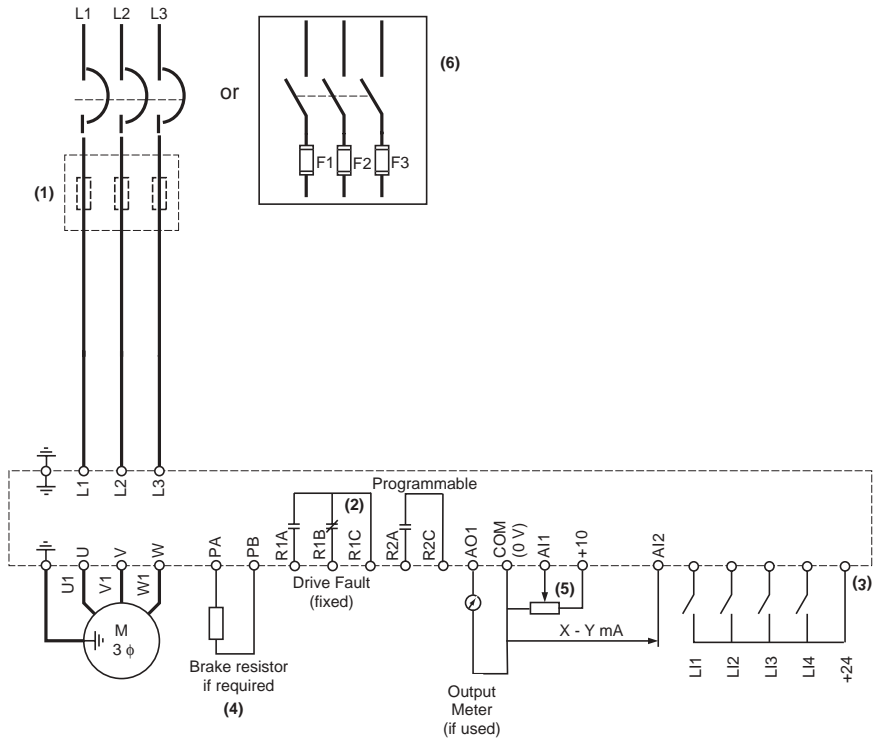

- (1) Line reactor if required. See catalog 8806CT9801 for recommendations.
- (2) Fault relay contacts for remote signalling of the drive controller state.
Contact state shown with drive controller deenergized or faulted.
- (3) Internal +24 V. When using +24 V external supply, connect the 0 V to the COM terminal.
Do not use the +24 terminal on the control board, but connect logic inputs to external +24 V.
- (4) See Appendix A for available braking resistor kits.
- (5) Manual speed potentiometer (1–10 kΩ)
- (6) Branch circuit protection (circuit breaker or fuses) must be installed.

Figure 25: Three-Phase Wiring Diagram

RECOMMENDED BRANCH CIRCUIT PROTECTION DEVICES

Branch circuit protection must be installed on the input (line side) of the drive controllers. Input fuses may be used on 1/2 hp to 500 hp drive controllers; circuit breakers may be used on 1/2 hp to 100 hp drive controllers.

Fuses

The fuses specified in Tables 34–36 (pages 66–68) are suitable for branch short circuit protection and provide excellent short circuit protection for the drive.

Circuit Breakers

The circuit breakers specified in Tables 38–40 (pages 69–71) will also provide branch short circuit protection. Because circuit breakers are typically slower than fuses, they are not as effective in limiting damage to the drive controller in the event of an internal drive short circuit such as shorted bus connections, shorted input rectifier, or failure of the internal solid state overcurrent protection circuit in the drive controller.

WARNING

RISK OF EXPLOSION, RISK OF EXPULSION OF DEBRIS AND EMISSION OF FLAME

To mitigate or avoid this hazard, implement one of the following precautions:

- Use the fuses listed in Tables 34–36 of this instruction bulletin as the overcurrent protective devices for the drive controller instead of circuit breakers.
- Locate the drive controller only in areas where the explosion, expulsion of debris, and emission of flame pose no hazards to personnel or property.
- Install the drive controller in an appropriate enclosure designed to contain the hazard.

Failure to observe this instruction can result in death or serious injury.

Table 34: Recommended Fuses: 208/230 V Single-Phase Drive Controllers

M Motor		A1 Drive Controller ATV58H•••••	F1-F2 Line Power Fuses Class J
hp	kW		
0.5	0.37	U09M2	10 ^[1]
1	0.75	U18M2	15 ^[1]
2	1.5	U29M2	30 ^[1]
3	2.2	U41M2	30 ^[1]
4	3	U72M2	35 ^[1]
5	4	U90M2	60 ^[1]
7.5	5.5	D12M2	70 ^[1]
10	7.5	D16M2	90 ^[2]
15	11	D23M2	125 ^[2]
20	15	D28M2	150 ^[2]
25	18.5	D33M2	175 ^[2]
30	22	D46M2	200 ^[2]

[1] Fast-acting or time delay Class J fuses are acceptable. Class T fuses are acceptable. Class CC fuses may be used if recommended fuse rating is 30 A or lower.

[2] Fast-acting Class J fuses. Class T fuses are acceptable.

CT	Constant Torque Rating
CTLN	Constant Torque Low Noise Rating
VTLN	Variable Torque Low Noise Rating
VT	Variable Torque Rating

Table 35: Recommended Fuses: 208/230 V Three-Phase Drive Controllers

M Motor		A1 Drive Controller	F1-F2-F3 Line Power Fuses
hp	kW	ATV58H•••••	Class J ^[1]
2	1.5	U29M2	15
3	2.2	U41M2	20
—	3	U54M2	30
5	4	U72M2	35
7.5	5.5	U90M2	60
10	7.5	D12M2	70

hp	kW	CTLN ATV58H•••••	F1-F2-F3 Class J ^[2]	CT, VTLN ATV58H• ••••	F1-F2- F3 Class J ^[2]	VT ATV58H •••••	F1-F2-F3 Class J ^[2]
10	7.5	D16M2	70				
15	11	D23M2	90	D16M2	70	D16M2	70
20	15	D28M2	110	D23M2	90	D16M2	90
25	18.5	D33M2	125	D28M2	110	D23M2	125
30	22	D46M2	175	D33M2	125	D28M2	150
40	30			D46M2	175	D33M2	175
50	37					D46M2	200

[1] Fast-acting or time delay Class J fuses are acceptable. Class T fuses are acceptable. Class CC fuses may be used if recommended fuse rating is 30 A or lower.

[2] Fast-acting Class J fuses. Class T fuses are acceptable.

CT	Constant Torque Rating
CTLN	Constant Torque Low Noise Rating
VTLN	Variable Torque Low Noise Rating
VT	Variable Torque Rating

Table 36: Recommended Fuses: 400/460 V Three-Phase Drive Controllers

Motor		Drive Controller CT, VTLN ATV58H*****	F1-F2-F3 Line Power Fuses	Drive Controller VTLN ATV58H*****	F1-F2-F3 Line Power Fuses
hp	kW		Class J [1]		Class J [1]
1	0.75	U18N4	5	—	—
2	1.5	U29N4	10	—	—
3	2.2	U41N4	12	—	—
—	3	U54N4	15	—	—
5	4	U72N4	20	U54N4X	20
7.5	5.5	U90N4	25	U72N4X	25
10	7.5	D12N4	40	U90N4X	40
15	11	D16N4	50	D12N4X	50
20	15	D23N4	70	D16N4X	70
25	18.5			D23N4X	70

hp	kW	CTLN ATV58H*****	F1-F2-F3 Class J [2]	CT, VTLN ATV58H*****	F1-F2-F3 Class J [2]	VT ATV58H*****	F1-F2-F3 Class J [2]
20	11	D28N4	70				
25	18.5	D33N4	80	D28N4	70	D28N4	70
30	22	D46N4	100	D33N4	80	D28N4	90
40	30	D54N4	125	D46N4	100	D33N4	110
50	37	D64N4	150	D54N4	125	D46N4	150
60	45	D79N4	200	D64N4	150	D54N4	175
75	55			D79N4	175	D64N4	200
100	75					D79N4	200

[1] Fast-acting or time delay Class J fuses are acceptable. Class T fuses are acceptable. Class CC fuses may be used if recommended fuse rating is 30 A or lower.

[2] Fast-acting Class J fuses. Class T fuses are acceptable.

Table 37: Recommended Fuses: 400/460 V Three-Phase Drive Controllers (continued)

hp	kW	VT ATV58H*****	F1-F2-F3 ^[1]
125	90	C10N4X	FWH-300A
150	110	C13N4X	FWH-400A
200	132	C15N4X	FWH-500A
250	160	C19N4X	FWH-600A
300	200	C23N4X	FWH-700A
350	220	C25N4X	FWH-800A
400	250	C28N4X	FWH-900A
450	280	C31N4X	FWH-900A
500	315	C33N4X	FWH-1000A

[1] Use the Bussmann part numbers provided or equivalent.

Table 38: Recommended Circuit Breakers: 208/230 V Single-Phase Drive Controllers

M Motor		A1 Drive Controller	Continuous Rating	Square D Breaker or Equivalent
hp	kW	ATV58H*****	A	
0.5	0.37	U09M2	15	FAL22015
1	0.75	U18M2	15	FAL22015
2	1.5	U29M2	30	FAL22030
3	2.2	U41M2	30	FAL22030
4	3	U72M2	35	FAL22035
5	4	U90M2	60	FAL22060
7.5	5.5	D12M2	70	FAL22070
10	7.5	D16M2	90	FAL22090
15	11	D23M2	125	KAL26125
20	15	D28M2	150	KAL26150
25	18.5	D33M2	175	KAL26175
30	22	D46M2	200	KAL26200

CT	Constant Torque Rating
CTLN	Constant Torque Low Noise Rating
VTLN	Variable Torque Low Noise Rating
VT	Variable Torque Rating

Table 39: Recommended Circuit Breakers: 208/230 V Three-Phase Drive Controllers

M Motor		A1 Drive Controller	Continuous Rating	Square D Breaker or Equivalent
hp	kW	ATV58H	A	
2	1.5	U29M2	15	FAL36015
3	2.2	U41M2	20	FAL36020
—	3	U54M2	30	FAL36030
5	4	U72M2	35	FAL36035
7.5	5.5	U90M2	60	FAL36060
10	7.5	D12M2	70	FAL36070

hp	kW	CTLN ATV58H	Cont. Rating (A)	Square D Breaker or Equiv.	CT, VTLN ATV58H	Cont. Rating (A)	Square D Breaker or Equiv.	VT ATV58H	Cont. Rating (A)	Square D Breaker or Equiv.
10	7.5	D16M2	70	FAL36070						
15	11	D23M2	90	FAL36060	D16M2	70	FAL36070	D16M2	70	FAL36070
20	15	D28M2	110	KAL36110	D23M2	90	FAL36060	D16M2	90	FAL36060
25	18.5	D33M2	125	KAL36125	D28M2	110	KAL36110	D23M2	110	KAL36110
30	22	D46M2	175	KAL36175	D33M2	125	KAL36125	D28M2	125	KAL36125
40	30				D46M2	175	KAL36175	D33M2	175	KAL36175
50	37							D46M2	200	KAL36200

CT	Constant Torque Rating
CTLN	Constant Torque Low Noise Rating
VTLN	Variable Torque Low Noise Rating
VT	Variable Torque Rating

Table 40: Recommended Circuit Breakers: 400/460 V Three-Phase Drive Controllers

Motor		CT, VTLN	Cont. Rating	Square D Breaker or Equiv.	VTLN	Cont. Rating	Square D Breaker or Equiv.
hp	kW	ATV58H	(A)		ATV58H	(A)	
1	0.75	U18N4	15	FAL36015	—	—	
2	1.5	U29N4	15	FAL36015	—	—	
3	2.2	U41N4	15	FAL36015	—	—	
—	3	U54N4	15	FAL36015	—	—	
5	4	U72N4	20	FAL36020	U54N4	20	FAL36020
7.5	5.5	U90N4	25	FAL36025	U72N4	25	FAL36025
10	7.5	D12N4	40	FAL36040	U90N4	40	FHL36040
15	11	D16N4	50	FHL36050	D12N4	50	FHL36050
20	15	D23N4	70	FHL36070	D16N4	70	FHL36070
25	18.5				D23N4	70	FHL36070

hp	kW	CTLN ATV58H	Cont. Rating (A)	Square D Breaker or Equiv.	CT, VTLN ATV58H	Cont. Rating (A)	Square D Breaker or Equiv.	VT ATV58H	Cont. Rating (A)	Square D Breaker or Equiv.
20	11	D28N4	70	FHL36070						
25	18.5	D33N4	80	FHL36080	D28N4	70	FHL36070	D28N4	70	FHL36070
30	22	D46N4	100	FHL36100	D33N4	80	FHL36080	D28N4	90	FHL36090
40	30	D54N4	125	KAL36125	D46N4	100	FHL36100	D33N4	110	KAL36110
50	37	D64N4	150	KAL36150	D54N4	125	KAL36125	D46N4	150	KAL36150
60	45	D79N4	200	KAL36200	D64N4	150	KAL36150	D54N4	175	KAL36175
75	55				D79N4	175	KAL36175	D64N4	200	KAL36200
100	75							D79N4	200	KAL36200

USING DYNAMIC BRAKING

Consult Table 41 for minimum ohmic values when selecting dynamic braking resistors.

Table 41: Minimum Ohmic Value of Dynamic Braking Resistors

ATV58*****	U09M2 U18M2	U29M2 U41M2	U54M2	U72M2	U72M2 D12M2	D16M2X	D23M2X	D28M2X	D33M2X	D46M2X
Min. Resistance Ω	75	38	31	25	13	8	8	4	2.67	2.67

ATV58*****	U18N4 U29N4 U41N4 U54N4	U72N4	U90N4	D12N4	D16N4 D23N4	D16N4, D28N4X D33N4, D33N4X D46N4, D46N4X'	D54N4, D54N4X	D64N4, D64N4X D79N4, D79N4X
Min. Resistance Ω	85	57	47	53	19	14	8	5

USING A LINE CONTACTOR

When controlling the power with an isolation line contactor, avoid frequently opening and closing the line contactor as this could cause premature failure of the drive controller. Use inputs LI1 to LI4 to start and stop the drive controller. Limit operations of the line contactor to less than once per minute.

Output Contactor Wiring Diagram

Relay R2 can be configured for the "Output Contactor Command" function. Refer to keypad display instruction bulletin VVDED397047US for more information on this function. In the wiring diagram, the shaded portion is to be added to either the single-phase input wiring diagram (Figure 24 on page 63) or the three-phase input wiring diagram (Figure 25 on page 64).

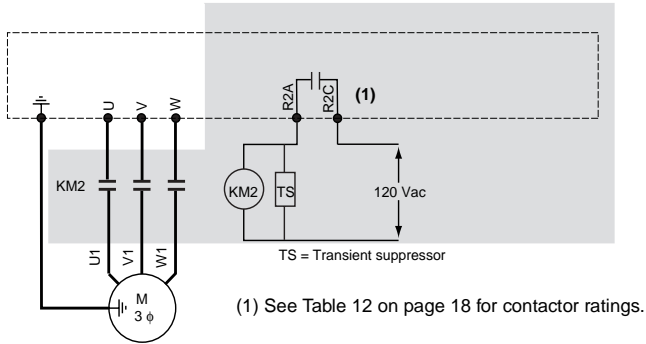

Figure 26: Output Contactor Wiring Diagram

NOTE: Use transient suppression on all inductive circuits (such as relays, contactors, and solenoids) near the drive controller or connected on the same circuit.

Table 42: Recommended Output Contactors

ATV58H.....	KM2 LC1-	ATV58H.....	KM2 LC1-
U09M2	D25 ^[1]	U18N4	D25 ^[1]
U18M2	D25 ^[1]	U29N4	D25 ^[1]
U29M2	D25 ^[1]	U41N4	D25 ^[1]
U41M2	D25 ^[1]	U72N4	D20 ^[1]
U72M2	D25 ^[1]	U90N4	D25 ^[1]
U90M2	D25 ^[1]	D12N4	D25 ^[1]
D12M2	D32 ^[1]	D16N4	D25 ^[1]
		D23N4	D40 ^[1]
D16M2	D40 ^[1]	D28N4	D40 ^[1]
D23M2	D80 ^[1]	D33N4	D50 ^[1]
D28M2	D80 ^[1]	D46N4	D80 ^[1]
D33M2	D80 ^[1]	D54N4	D80 ^[1]
D46M2	F115 ^[1]	D64N4	F115 ^[1]
		D79N4	F115 ^[1]

[1] Refer to the Square D Digest for other control voltages.

EXTERNAL 24 V SUPPLY

An external 24 V power supply can be used for the logic inputs. In this case, the +24 terminal on the drive controller is not used. Figure 27 illustrates wiring when an external supply is used.

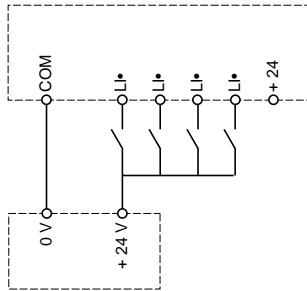

Figure 27: External Supply Wiring Diagram

FAULT RELAY

The fault relay is energized whenever the drive controller is powered up and there is no fault. It provides a normally-open and a normally-closed contact.

To reset the drive controller after a fault, cycle the power, allowing the red LED to turn off.

AVAILABLE MOTOR TORQUE

Continuous duty:

- For self-ventilated motors, motor cooling depends on the speed.
- Continuous duty results in derating for speeds less than 50% of the nameplate motor speed.

Operation in overspeed:

- In overspeed operation, the voltage does not increase with the frequency, resulting in reduced induction in the motor and loss of torque. Consult the motor manufacturer to ensure that the motor can operate in overspeed.

- For a special motor, the nominal frequency and the maximum frequency can be adjusted between 40 and 500 Hz using the keypad display, handheld programmer, or test & commissioning software. See Appendix A for a list of accessories.

⚠ CAUTION

MACHINERY OVERSPEED

Some motors and/or loads may not be suited for operation above nameplate motor speed and frequency. Consult the motor manufacturer before operating motor above rated speed.

Failure to follow this instruction can result in injury or equipment damage.

The available overtorque depends on the motor design category. For typical NEMA Design B motors, the ATV58 TRX controller can deliver 200% of the nominal motor torque for 2 seconds, and 170% for 60 seconds.

The motor power rating must be at least 25% of drive controller rated power for the drive controller to properly operate the motor.

Figure 28 shows the typical torque characteristics of the ATV58 TRX drive controller.

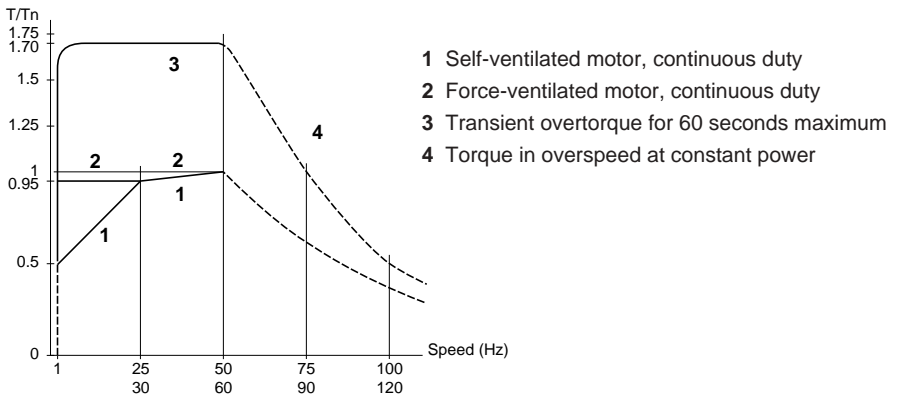

Figure 28: Typical Torque Characteristics

FACTORY SETTINGS

The ATV58 TRX drive controller is preset for constant torque applications. Table 43 lists the factory settings. See Appendix A for available configuration tools to alter factory settings.

Table 43: Factory Settings

Function	Setting															
Base frequency	50/60 Hz ^[1]															
Motor voltage	230 V or 400/460 V ^[1] , depending on the model															
Acceleration and deceleration ramps	3 s															
Low speed	0 Hz															
High speed	50/60 Hz ^[1]															
Maximum frequency	60/72 Hz ^[1]															
Motor thermal current	0.9 times rated drive controller output current															
DC braking current at stop	0.63 times rated drive controller output current for 0.5 s															
Operation	Constant torque															
Control type	2-wire control															
Logic inputs	LI1: Run Forward; LI2: Run Reverse <table border="1"> <thead> <tr> <th>LI3</th> <th>LI4</th> <th>Preset speed</th> </tr> </thead> <tbody> <tr> <td>0</td> <td>0</td> <td>Low speed + reference</td> </tr> <tr> <td>1</td> <td>0</td> <td>10 Hz</td> </tr> <tr> <td>0</td> <td>1</td> <td>15 Hz</td> </tr> <tr> <td>1</td> <td>1</td> <td>High speed</td> </tr> </tbody> </table> ATV58HC13N4X to C33N4X: LI1: run forward; LI2 run reverse LI3: fault reset; LI4 not assigned	LI3	LI4	Preset speed	0	0	Low speed + reference	1	0	10 Hz	0	1	15 Hz	1	1	High speed
LI3	LI4	Preset speed														
0	0	Low speed + reference														
1	0	10 Hz														
0	1	15 Hz														
1	1	High speed														
Analog inputs	AI1: 0 to +10 V speed reference AI2: 4 to 20 mA speed reference Analog inputs set for reference summing															
Analog output	Motor frequency															
Relay outputs	R1: fault relay (cannot be reassigned) R2: not assigned (can be reassigned) ATV58HC13N4X to C33N4X: R2: drive running															
Switching frequency	4 kHz ATV58HC13N4X to C33N4X: 2 kHz															

[1] Depending on the position of the 50/60 Hz switch. Switch is factory-set to 60 Hz.

START UP

DANGER

HAZARDOUS VOLTAGE

- Read and understand this bulletin in its entirety before installing or operating ALTIVAR 58 TRX drive controllers. Installation, adjustment, repair, and maintenance of the drive controllers must be performed by qualified personnel.
- The user is responsible for conforming to all applicable code requirements with respect to grounding all equipment.
- Many parts in this drive controller, including printed wiring boards, operate at line voltage. DO NOT TOUCH. Use only electrically insulated tools.
- DO NOT short across DC bus capacitors or touch unshielded components or terminal strip screw connections with voltage present.
- Before servicing the drive controller:
 - Disconnect all power including external control power that may be present before servicing the drive controller.
 - Place a “DO NOT TURN ON” label on the drive controller disconnect.
 - Lock the disconnect in open position.
 - WAIT TEN MINUTES for the DC bus capacitors to discharge. Then follow the DC bus voltage measurement procedure on page 42 to verify that the DC voltage is less than 45 V. The drive controller LEDs are not accurate indicators of the absence of DC bus voltage.
- Install and close all covers before applying power or starting and stopping the drive controller.

Electrical shock will result in death or serious injury.

Before powering up the drive controller, the 50/60 Hz switch must be set to correspond with the incoming power frequency. Unlock and open the cover to access the 50/60 Hz switch on the control board. Set the switch to the position corresponding to the mains frequency.

The pre-adjusted operating voltage corresponding to the switch position is:

- 50 Hz Position:
 - 230 V, 50 Hz for ATV58H•••M2
 - 400 V, 50 Hz for ATV58H•••N4
- 60 Hz Position (Factory Setting):
 - 230 V, 60 Hz for ATV58H•••M2
 - 460 V, 60 Hz for ATV58H•••N4

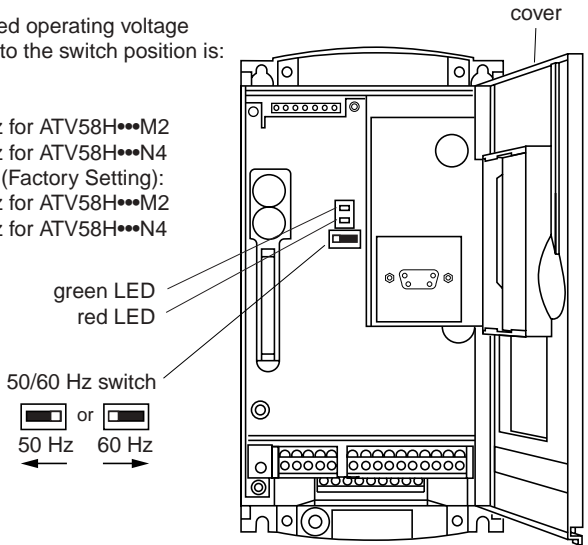

Figure 29: Setting the 50/60 Hz Switch

Several tools, ordered separately, are available to assist with starting up the ATV58 TRX drive controller:

- Keypad display, VW3A58101U. The drive controller is shipped without the keypad display.
- Handheld PC with test and commissioning software, VW3A8108US
- PC test & commissioning software connection, PowerSuite, VW3A58104
- PC connection cable, VW3A8106

Consult the documentation provided with each of these tools for start up and maintenance information.

If your ATV58 TRX controller has an I/O extension card or communication card, also consult the documentation provided with the card.

LIGHT EMITTING DIODES (LEDs)

The LEDs on the front of the ATV58 TRX controller indicate several states as shown in Figure 30.

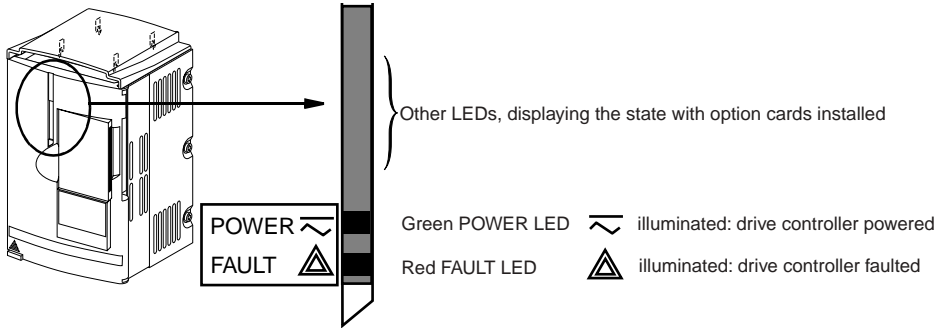

Figure 30: LED States

PREVENTIVE MAINTENANCE

Perform the following checks at regular intervals:

- Check the condition and tightness of the connections.
- Make sure ventilation is effective and the temperature around the drive controller remains at an acceptable level.
- Remove dust and debris from the drive controller, if necessary.

TROUBLESHOOTING AND MAINTENANCE

When a fault is detected, the drive controller trips and the fault relay deenergizes.

After performing the “Bus Voltage Measurement Procedure” on page 42, check the supply voltage (Procedure 1 on page 80) and the peripheral components (Procedure 2 on page 80).

If no problem is found with the supply voltage and peripheral equipment, install a keypad display for additional fault information. The faults are identified in the keypad display manual, VVDED397047US.

Procedure 1: Checking the Supply Voltage

To determine if the voltage is within the drive controller tolerance:

1. Perform the bus voltage measurement procedure on page 42.
2. Attach meter leads to L1 and L2. Set the voltmeter to the 600 Vac scale.
3. Reapply power and check for the correct line voltage, shown on the drive controller nameplate rating.
4. Remove power and repeat the procedure for L2 and L3, and L1 and L3.
5. When all phases have been measured, remove power. Remove leads and replace all covers.

Procedure 2: Checking the Peripheral Equipment

The following equipment may need to be checked. Follow the manufacturers' procedures when checking this equipment.

1. A protective device such as a fuse or circuit breaker may have tripped.
2. A switching device such as a contactor may not be closing at the correct time.
3. Conductors may require repair or replacement.
4. Connection cables to the motor or high resistance connections to ground may need to be checked. Follow NEMA standard procedure WC-53.
5. Motor insulation may need to be checked. Follow NEMA standard procedure MG-1. Do not apply high voltage to U, V, or W. Do not connect the high potential dielectric test equipment or insulation resistance tester to the drive controller since the test voltages used may damage the drive controller. Always disconnect the drive controller from the conductors or motor while performing such tests.

⚠ CAUTION

**DIELECTRIC TESTS, WHEN CONNECTED,
CAN CAUSE EQUIPMENT DAMAGE**

Do not perform high potential dielectric tests on circuits while the circuits are connected to the drive controller.

Any circuit requiring high potential dielectric tests must be disconnected from the drive controller prior to performing the test.

Failure to follow this instruction can result in injury or equipment damage.

Fault Storage

The first fault detected is saved and displayed on the optional keypad display if power is maintained. The drive controller trips and the fault relay opens.

To reset the fault:

1. Remove power from the drive controller.
2. Before switching power back on, identify and correct the cause of the fault.
3. Restore power. This will reset the fault if it has been corrected.

In certain cases, if automatic restart has been enabled, the drive controller can be automatically restarted after the cause of the fault has disappeared.

The Test & Commissioning software can be used to view the last eight faults recorded by the drive controller. See Appendix A for the part number.

APPENDIX A: OPTIONS AND ACCESSORIES

Table 44 shows the accessories available for ATV58 TRX drive controllers and Table 45 contains a repair parts list.

Table 44: ATV58 TRX Accessories

Catalog No.	Description
VW3A8104	PowerSuite Test & Commissioning Software on CD for use with Microsoft® Windows 95, 98, and NT™ and Windows CE v3.0 for Pocket PCs
VW3A8106	Cable and RS-232 to RS-485 Adapter for Connection of PC to an ATV58 controller
VW3A8108US	PowerSuite Pak includes: HP JORNADA 525, PowerSuite CD VW3A8104, and connection cable VW3A8111
VW3A8111	Cable and RS-232 to RS-485 adaptor for connection of an HP JORNADA 525 Pocket PC to an ATV58 controller
VW3A58101U	Keypad Display
VW3A58103	Remote Mounting Kit for Keypad (IP65 rated)
VW3A58201U	Analog I/O Option Card
VW3A58202U	Digital I/O Option Card
VW3A58210U	Pump Switching Card
VW3A58253U	General Purpose Option Card
VW3A58301U	FIPIO® Communication Card
VW3A58302U	MODBUS® Plus Communication Card
VW3A58303U	MODBUS/UNITELWAY™ Communication Card
VW3A58304EU	Interbus S Communication Card. Requires external power supply.
VW3A58306U	RS-485 Cable w/ MODBUS Mapping Guide
VW3A58307U	Profibus DP Communication Card
VW3A58309U	DeviceNet™ Communication Card
VW3A58310U	Ethernet MODBUS TCP/IP Communication Card
VW3A58312PU	LONWORKS® to MODBUS DIN Rail Mount Gateway
VW3A58354U	JOHNSON CONTROLS® N2 Communication Card
VW3A58701	DB Transistor for ATV58HU09M2 and U18M2
VW3A58821	Fan Kit for ATV58HU09M2 and U18M2
VW3A58822	Fan Kit for ATV58HU29M2, U41M2, and U18N4 to U41N4
VW3A58823	Fan Kit for ATV58HU54M2, U72M2, and U54N4 to U90N4
VW3A58824	Fan Kit for ATV58HU90M2, D12M2, and D12N4 to D23N4
VW3A58825	Fan Kit for ATV58HD16M2, D23M2, and D28N4 to D46N4
VW3A58826	Fan Kit for ATV58HD28M2 to D46M2 and D54N4 to D79N4

Continued on next page.

Table 44: ATV58 TRX Accessories (Continued)

Catalog No.	Description
VW3A58831	EMC Kit for ATV58HU09M2 and U18M2
VW3A58832	EMC Kit for ATV58HU29M2, U41M2, and U18N4 to U41N4
VW3A58833	EMC Kit for ATV58HU54M2, U72M2, and U54N4 to U90N4
VW3A58834	EMC Kit for ATV58HU90M2, D12M2, and D12N4 to D23N4
VW3A58842	Conduit Box Kit for ATV58HU09M2 and U18M2
VW3A58843	Conduit Box Kit for ATV58HU29M2, U41M2, and U18N4 to U41N4
VW3A58844	Conduit Box Kit for ATV58HU54M2, U72M2, and U54N4 to U90N4
VW3A58845	Conduit Box Kit for ATV58HU90M2, D12M2, and D12N4 to D23N4
VW3A58846	Conduit Box for ATV58HD16M2, D23M2, and D28N4 to D46N4
VW3A58847	Conduit Box for ATV58HD28M2 to D46M2 and D54N4 to D79N4
VW3A66711	DB Resistor Kit for ATV58HU09M2, U18M2, U18N4 to U72N4
VW3A66712	DB Resistor Kit for ATV58HU29M2, U41M2, U90N4, D12N4
VW3A66713	DB Resistor Kit for ATV58HU54M2, U72M2, D16N4, D23N4
VW3A66714	DB Resistor Kit for ATV58HU90M2, D12M2, and D28N4 to D46N4
VW3A66715	DB Resistor Kit for ATV58HD16M2, D23M2, D54N4
VW3A66716	DB Resistor Kit for ATV58HD28M2, D33M2, D46M2, D64N4, and D79N4

Table 45: Repair Part List for ATV58 TRX Controllers

	Description	For Use on Drives	Catalog Number
	ATV58 TRX Control Board Kit	ATV58 Type E,F,H, and N	VX4A581U
Internal fan kit	Frames 2 and 3 (two fans)	ATV58 ..U29M2, U41M2, U54M2, U72M2, U18N4, U29N4, U41N4, U54N4, U72N4, U90N4	VZ3V58223U
	Frames 4 and 5 (three fans)	ATV58 ..U90M2, D12M2, D12N4, D16N4, D23N4	VZ3V58245U
	Frame 6 (four fans)	ATV58 ..D16M2, D23M2, D28N4, D33N4, D46N4	VZ3V58260U
	Frame 7 (four fans)	ATV58 ..D28M2, D33M2, D46M2 D54N4, D64N4, D79N4	VZ3V58270U
Terminals	Removable ATV58 Control Board Terminal Strips Includes relay terminal strip, 9 position terminal strip, and 10 position terminal strip.	ATV58 Type E, F, H, and N	VZ3N581U
	Power Terminal Block for Frame 6	ATV58 ..D16M2, D28N4, D33N4	VZ3N58160U
	Power Terminal Block for Frame 6	ATV58 ..D23M2, D46N4	VZ3N58165U
	Power Terminal Block for Frame 7	ATV58 ..D28M2, D33M2, D46M2 D54N4, D64N4, D79N4	VZ3N58170U
Internal EMC Filter Kit	Internal RFI filter kit for Frame 6	ATV58HD28N4	VX4A58861U
		ATV58HD33N4	VX4A58862U
		ATV58HD46N4	VX4A58863U
	Internal RFI filter kit for Frame 7	ATV58HD54N4	VX4A58871U
		ATV58HD64N4	VX4A58872U
		ATV58HD79N4	VX4A58873U
Power Boards for Frames 6 and 7		ATV58HD16M2	VX5A58D16M2U
		ATV58HD23M2	VX5A58D23M2U
		ATV58HD28M2	VX5A58D28M2U
		ATV58HD33M2	VX5A58D33M2U
		ATV58HD46M2	VX5A58D46M2U
		ATV58HD28N4	VX5A58D28N4U
		ATV58HD33N4	VX5A58D33N4U
		ATV58HD46N4	VX5A58D46N4U
		ATV58HD54N4	VX5A58D54N4U
		ATV58HD64N4	VX5A58D64N4U
	ATV58HD79N4	VX5A58D79N4U	

Table 45: Repair Part List for ATV58 TRX Controllers (Continued)

	Description	For Use on Drives	Catalog Number
Power Components	Output transistor module	ATV58...D28N4	VZ3IM6075M1258U
		ATV58...D16M2, D33N4	VZ3IM6100M1258U
		ATV58...D23M2, D28M2, D46N4, D54N4	VZ3IM6150M1258U
		ATV58...D33M2, D46M2, D64N4, D79N4	VZ3IM2200M1258U
	Dynamic braking transistor	ATV58..D16M2, D23M2, D28N4, D33N4, D46N4	VZ3IM1050M1258U
		ATV58...D28M2, D54N4	VZ3IM1100M1258U
		ATV58...D33M2, D46M2, D64N4, D79N4	VZ3IM1150M1258U
	Input diode / transistor bridge	ATV58...D16M2, D28N4, D33N4	VZ3TD1055M1658U
		ATV58...D23M2, D28M2, D46N4, D54N4	VZ3TD1090M1658U
		ATV58...D33M2, D46M2, D64N4, D79N4	VZ3TD1130M1658U

Factory repaired ATV58 TRX drive controllers are available within 24 hours from a factory exchange pool, or your drive controller can be factory repaired and returned. Contact your local Square D Distributor or Square D Customer Service Representative at 919-266-8600 for availability.

Numerics

50/60 Hz switch 77, 78

A

acceleration ramp 76
altitude 17
analog inputs 62, 76
applications 6

B

branch circuit protection 65
bus voltage measurement 42

C

cable
 length 56
 type 56
capacitance 56
CE directives
 electromagnetic compatibility 33
 machinery 33
circuit breakers 65
 recommended 69–71
clearances
 minimum 26
codes and standards 20
condensation 30, 31
constant torque 6, 76
control type 76
control ventilation kit 28
current

braking 76
fault 46
input line 46
maximum thermal 76
transient output 19

D

DC injection braking 19
deceleration ramp 76
dimensions 21
 frame size 1 21
 frame size 10 25
 frame size 2 21
 frame size 3 21
 frame size 4 21
 frame size 5 21
 frame size 6 22
 frame size 7 22
 frame size 8 23
 frame size 9 24
disconnect switch 26
displacement power factor 18
dynamic braking
 connection 59
 resistors 72

E

efficiency 18
electromagnetic compatibility 33
EMC filters 5
EMC. See electromagnetic compatibility
enclosure type 17
enclosures
 calculating size 31
 general purpose 30

Type 12 (IP54) 31
ethernet 5
external power supply 74

F

factory settings 76
fans
 flow rates 30
 stirring 31
 ventilation 30
fault relay. See relays
faults
 resetting 81
filters 30
frequency
 input 18
 maximum 76
 output 18
 switching. See switching frequency
fuses 46, 65
 line power 66, 67, 68
 recommended 66–69

G

grounding 57–58

H

handheld programmer 75, 78
humidity 17

I

installation 26

K

keypad display 75, 78

L

LEDs 74, 79
line contactor 72
line reactors 5
logic inputs 62, 72, 76
lug installation 59–60

M

maintenance 79
metallic conduit 45
motor control algorithm 19
motors
 self-ventilated 74
 special 75
mounting
 general purpose enclosure 30
 Type 12 (IP54) enclosure 31

O

operating position 17
options 6
output contactors 73
overspeed operation 74

P

peripheral equipment
 checking 80
pollution degree 17, 26

potentiometer 62
protection 26
 drive controller 19
 motor 19
 thermal 19

R

range 5
ratings
 208 to 230 V controllers 8–12,
 47–51
 400 to 460 V controllers 13–
 16, 52–55
receiving 7
recommended equipment
 208/230 V controllers 67, 70
 400/460 V controllers 68, 71
relay outputs 76
relays 45, 61
 fault 74

S

shield connection 61
shipping 7
 damage 7
specifications
 electrical 18
 environmental 17
speed range 18
speed regulation 18
start up 77
storing 7
supply voltage
 checking 80
switching frequency 18, 76

T

temperature 17, 28
terminals
 control 61
 location
 DC bus measurement 44
 frame size 1 34
 frame size 10 41
 frame size 2 35
 frame size 3 35
 frame size 4 36
 frame size 5 36
 frame size 6 37
 frame size 7 38
 frame size 8 39
 frame size 9 40
 power 58
test and commissioning software
75, 78
torque
 available motor 74
 braking 19
 transient motor 19
transparent ready 5

V

ventilation 30, 79
vibration 17
voltage
 input 18
 output 18

W

weights 21–25
wiring

branch circuit components 46
control 45
diagrams 63–74
general practices 45
minimum inductance 56
output 56
output contactor 72
power 45
single phase input 63
three phase input 64

ALTIVAR® 58 TRX Type H Drive Controllers
Installation Guide



Square D
8001 Hwy 64 East
Knightdale, NC 27545 USA
1-888-SquareD (1-888-778-2733)
www.SquareD.com

LONWORKS is a trademark of Echelon Corporation registered in the United States and other countries.

Electrical equipment should be installed, operated, serviced, and maintained only by qualified personnel. No responsibility is assumed by Schneider Electric for any consequences arising out of the use of this material.

Bulletin No. VVDED397048USR8/02
© 1998-2002 Schneider Electric All Rights Reserved
Replaces VVDED397048US R7/02 dated 07/02.