

Data Bulletin

ALTIVAR[®] 58 Option Ethernet MODBUS[®] TCP/IP Communication Card, VW3A58310U Class 8806

INTRODUCTION

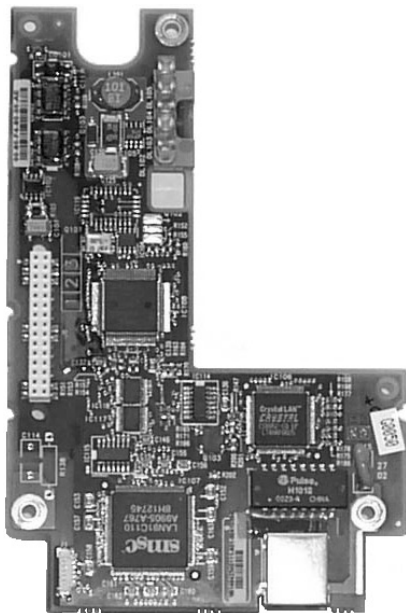

FEATURES

Embedded Web Pages

The ALTIVAR 58 (ATV58) family of adjustable-speed AC drive controllers for three-phase asynchronous motors is the first truly universal range of drive controllers. Only the ATV58 controller offers a combination of small size, outstanding performance, and modern communication capabilities coupled with a wide range of standard and optional features. For a complete description of the available options and enclosure types, refer to the ATV58 AC Drives catalog, 8806CT9901. This catalog is available from the Technical Library at www.SquareD.com or from your local Square D field office.

Description

The VW3A58310U Ethernet MODBUS TCP/IP communication option provides the entire ATV58 line of controllers with a direct connection to an Ethernet-based network. This communication network offers a flexible, cost-effective solution for communicating ATV58 drive information to various layers of an integrated manufacturing facility. Embedded Web pages on the option card allow access from anywhere around the globe to real-time information from the drive controller system using a standard Web browser.

Kit Contents

- Option card with integral RJ45 Ethernet receptacle
- Mounting hardware
- Instruction bulletin VVDED300053US (also available at www.SquareD.com)

The ATV58 controller can use the option card to receive and respond to Ethernet messages. This data exchange—which uses MODBUS TCP/IP protocol—gives the network access to ATV58 functions such as:

- Downloading adjustment parameters
- Writing and reading command and control registers
- Monitoring process variables
- Archiving statistics and drive identification
- Diagnostics and fault status

The option card mounts on any ATV58 drive controller without taking up additional panel space.

The Ethernet communication option card contains the following embedded Web pages:

- | | |
|-----------------------|---|
| • Home page | • Periodic Parameters page for I/O scanning |
| • Index page | • Security and Password Assignment page |
| • Statistics pages | • Data Editor page for drive parameter modification |
| • ALTIVAR Viewer page | |

SOFTWARE SET-UP

Each option card contains a unique MAC address. To assign an IP address, a sub-network address, and a gateway address to the card, use one of the following:

- Keypad display unit
- PC-based configuration software
- Bootstrap protocol from a PC or PLC
- Other IP address server types

Once programmed, these addresses are stored on the option card.

The Ethernet communication option is designed for use with the Schneider Automation offering of programmable logic controllers (PLCs) such as the Quantum, Premium, and Momentum families. These families offer the following Ethernet-compatible modules, which are programmed to interface with ATV58 controllers:

- **Quantum:** 140NOE77100
- **Premium:** TSXETY410 or TSXETY5101
- **Momentum:** 171CCC96020, 171CCC96030, 171CCC98020, or 171CCC98030

These PLC Ethernet modules support the I/O Scanning function, a feature required for successfully commanding the ATV58 drive controller using the Ethernet card. To configure the PLC Ethernet modules, use one of the following Schneider Automation programming software packages:

- PL7 PRO™
- CONCEPT™
- PROWORX NXT®

TRANSPARENT FACTORY® SYSTEM INCLUDING ATV58 CONTROLLERS

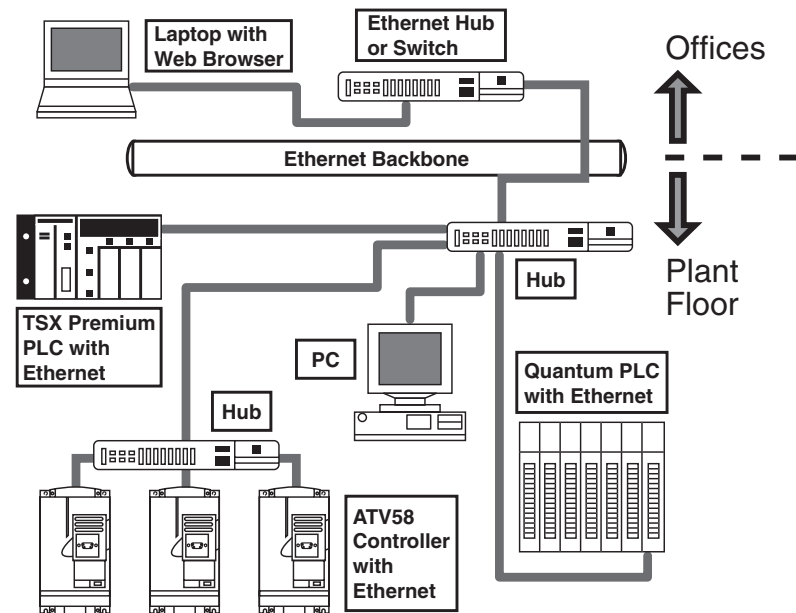

Figure 1: TRANSPARENT FACTORY Concept

Square D Company
8001 Highway 64 East
Knightdale, NC 27545
1-888-SquareD (1-888-778-2733)
www.SquareD.com

Electrical equipment should be serviced only by qualified personnel. No responsibility is assumed by Schneider Electric for any consequences arising out of the use of this material.

Bulletin No. 8806DB0101 June 2001