

Instruction Bulletin

ALTIVAR[®] 58 *TRX* Adjustable Speed Drive Controllers

Installation Guide Type F Controller

Retain for Future Use.



DANGER

HAZARDOUS VOLTAGE

- Read and understand this bulletin in its entirety before installing or operating ALTIVAR 58 *TRX* drive controllers. Installation, adjustment, repair, and maintenance of the drive controllers must be performed by qualified personnel.
- The user is responsible for conforming to all applicable code requirements with respect to grounding all equipment.
- Many parts in this drive controller, including printed wiring boards, operate at line voltage. **DO NOT TOUCH.** Use only electrically insulated tools.
- **DO NOT** short across DC bus capacitors or touch unshielded components or terminal strip screw connections with voltage present.
- Before servicing the drive controller:
 - Disconnect all power including external control power that may be present before servicing the drive controller.
 - Place a “DO NOT TURN ON” label on the drive controller disconnect.
 - Lock the disconnect in open position.
 - **WAIT THREE MINUTES** for the DC bus capacitors to discharge. Then follow the DC bus voltage measurement procedure on page 13 to verify that the DC voltage is less than 45 V. The drive controller LEDs are not accurate indicators of the absence of DC bus voltage.
- Install and close all covers before applying power or starting and stopping the drive controller.

Electrical shock will result in death or serious injury.

INTRODUCTION	5
Product Range	5
Product Features	5
Related Documentation	6
RECEIVING AND PRELIMINARY INSPECTION	6
STORING AND SHIPPING	6
TECHNICAL CHARACTERISTICS	7
SPECIFICATIONS	9
DIMENSIONS AND WEIGHTS	11
INSTALLATION PRECAUTIONS	12
BUS VOLTAGE MEASUREMENT PROCEDURE	13
Removing the Drive Controller Cover	15
WIRING	17
General Wiring Practices	17
Conduit Connections	18
Branch Circuit Connections	18
Output Wiring Precautions	20
Grounding	21
Power Terminals	23
Control Terminals	24
WIRING DIAGRAMS	26
Single-Phase Input	26
Three-Phase Input	27
RECOMMENDED POWER FUSES	28
USING AN EXTERNAL LINE CONTACTOR	29
EXTERNAL 24 V SUPPLY	29
FAULT RELAY	29
INSTALLING THE OPTION CARDS	30
INSTALLING THE COMMUNICATION CABLES	31
AVAILABLE MOTOR TORQUE	32
FACTORY SETTINGS	33
START UP	35
LIGHT EMITTING DIODES (LEDS)	37
PREVENTIVE MAINTENANCE	37

TROUBLESHOOTING AND MAINTENANCE..... 37
 Procedure 1: Checking Supply Voltage 37
 Procedure 2: Checking the Peripheral Equipment..... 38
 Fault Storage 38
APPENDIX A: OPTIONS AND ACCESSORIES 40
APPENDIX B: REPAIR PARTS..... 41
APPENDIX C: INTERNAL WIRING..... 42

INTRODUCTION

The ALTIVAR 58 TRX (ATV58 TRX) series of adjustable frequency AC drive controllers is a Transparent Ready™ product line providing extended functionality and an extended horsepower range for the ALTIVAR 58 AC drive family. The ATV58 TRX series includes an analog output and expanded firmware capabilities. As a Transparent Ready product equipped with an Ethernet connection, the ATV58 TRX product line can be configured, controlled, monitored, and diagnosed over an Ethernet network with a standard Web browser. No special software or drivers are needed.

The ATV58 TRX product line updates apply to drive controllers manufactured after August, 2002.

Product Range

The ATV58 TRX Type F construction offers a drive controller in a Type 12 enclosure. The Type F controllers are available in the following ranges:

- 1 to 7.5 hp (0.75 to 5.5 kW), 400/460 V, three-phase input
- 0.5 to 3 hp (0.37 to 2.2 kW), 208/230 V, single-phase input
- 2 to 3 hp (1.5 to 2.2 kW), 208/230 V, three-phase input

Product Features

The ATV58 TRX Type F drive controller contains:

- A Vario switch
- Input line fuses
- An ATV58 TRX drive controller
- Start-stop push buttons (16 mm)
- A manual speed potentiometer
- Space for one additional 16 mm operator
- Four conduit openings that are closed with plugs (see page 18 for sizes)
- A transparent plastic door for viewing status LEDs and a separately supplied keypad

All ATV58 TRX communication and I/O options can be used with the Type F drive controllers. Refer to Appendix A for a list of the options.

Related Documentation

This instruction bulletin covers the technical characteristics, specifications, installation, and wiring of ATV58 TRX Type F drive controllers.

For information on programming and troubleshooting the drive controller, refer to instruction bulletin VVDED397047US supplied with the optional keypad display (catalog no. VW3A58101U).

RECEIVING AND PRELIMINARY INSPECTION

 CAUTION
EQUIPMENT DAMAGE HAZARD
Do not operate or install any drive controller that appears damaged. Failure to follow this instruction can result in injury or equipment damage.

Before installing the drive controller, read this manual and follow all precautions.

Before removing the drive controller from its packaging, verify that the carton is not damaged from shipping. Damage to the carton usually indicates improper handling. If any damage is found, notify the carrier and your Square D representative.

After removing the drive controller from its packaging, inspect it for shipping damage. If any damage is found, notify the carrier and your Square D representative. Verify that the drive controller nameplate and label conform to the packing slip and corresponding purchase order.

STORING AND SHIPPING

If the drive controller is not being immediately installed, store it in a clean, dry area where the ambient temperature is between -13 to +149 °F (-25 to +65 °C). If the drive controller must be shipped to another location, use the original shipping material and carton to protect the drive controller.

TECHNICAL CHARACTERISTICS

Tables 1–3 show the ratings of the ATV58 TRX Type F drive controllers.

Table 1: Constant Torque and Variable Torque, 208/230 V Ratings, Single-Phase Input • Three-Phase Output, Switching Frequency @ 4 kHz

Product Frame Size	Drive Controller Catalog Number	Motor Power		Rated Output Current	Transient Output Current
		kW	hp	A	A
1	ATV58EU09M2FZU	0.37	0.5	2.3	3.1
1	ATV58EU18M2FZU	0.75	1	4.1	5.6
2	ATV58EU29M2FZU ^[1]	1.5	2	7.8	10.6
3	ATV58EU41M2FZU ^[1,2]	2.2	3	11.0	15.0

^[1] These devices are provided with three (3) input fuses. They are suitable for single phase or three phase input. Refer to pages 26 and 27 for wiring diagrams.

^[2] A 3% line reactor must be used with this drive controller when using single-phase input.

Table 2: Constant Torque and Variable Torque, 208/230 V Ratings, Three-Phase Input • Three-Phase Output, Switching Frequency @ 4 kHz

Product Frame Size	Drive Controller Catalog Number	Motor Power		Rated Output Current	Transient Output Current
		kW	hp	A	A
2	ATV58EU29M2FZU	1.5	2	7.8	10.6
3	ATV58EU41M2FZU	2.2	3	11.0	15.0

Table 3: Constant Torque and Variable Torque, 400/460 V Ratings, Three-Phase Input • Three-Phase Output, Switching Frequency @ 4 kHz

Product Frame Size	Drive Controller Catalog Number	Motor Power		Rated Output Current A	Transient Output Current A
		400 kW	460 hp		
2	ATV58EU18N4FZU	0.75	1	2.3	3.1
2	ATV58EU29N4FZU	1.5	2	4.1	5.6
2	ATV58EU41N4FZU	2.2	3	5.8	7.9
3	ATV58EU54N4FZU	3	–	7.8	10.6
3	ATV58EU72N4FZU	4	5	10.5	14.3
3	ATV58EU90N4FZU	5.5	7.5	13.0	17.7

SPECIFICATIONS

Table 4: Environmental Specifications

Enclosure type	Type 12 per UL 50 / NEMA Publication 250
Resistance to vibrations	According to IEC 60068-2-6: 1.5 mm zero to peak from 2 to 13 Hz 1 gn from 13 to 200 Hz
Resistance to shocks	According to IEC 60068-2-27: 10 gn, 11 ms
Ambient pollution degree	Pollution degree 2 according to IEC 60664-1, EN50718 and NEMA ICS-1. Protect the drive controller against dust, corrosive agents, and falling and splashing liquid.
Maximum relative humidity	95% according to IEC 60068-2-3.
Maximum ambient temperature	Storage: -25 to +65 °C (-13 to +149 °F) Operation: -10 to +40 °C (+14 to 104 °F)
Altitude	3300 ft (1000 m) maximum without derating; derate the output current by 1% for each additional 330 ft (100 m)
Operational position	Vertical, $\pm 10^\circ$, with power terminals at the bottom.

Table 5: Electrical Specifications

Input voltage	208 V -15% to 230 V +15% single phase input 208 V -15% to 230 V +15% three phase input 400 V -15% to 460 V +20% three phase input
Input frequency	50/60 Hz $\pm 5\%$
Output voltage	Three-phase output, maximum voltage equal to input voltage
Galvanic isolation	Galvanic isolation between power and control (inputs, outputs, power supplies)
Output frequency	0.1 to 60 Hz (configurable to 500 Hz with programming options) ^[1]
Switching frequency	4 kHz, configurable with programming options ^[1] 0.5 - 1 - 2 - 4 kHz without derating 8 - 12 - 16 kHz with derating in steady state or without derating with reduced duty cycle. For switching frequency between 8 and 16 kHz, use the next largest size drive controller. For example, for 1 hp @ 460 V, order drive controller ATV58EU29N4FZU. If the duty cycle (i.e., drive controller run time) does not exceed 60% (36 seconds maximum for a 60 seconds cycle), this is not necessary.
Speed range	1:100

^[1] See Appendix A for a list of accessories.

^[2] Motor power rating must be between 25% minimum, 136% maximum, of drive controller rating.

Table 5: Electrical Specifications (Continued)

Speed regulation	1% of rated motor speed without adjustments or feedback. $\pm 0.1\%$ of rated motor speed with optional analog I/O card and appropriate tachometer feedback. ^[1] $\pm 0.02\%$ of rated motor speed with optional digital I/O card and appropriate encoder feedback. ^[1]
Efficiency	97% at full load typical.
Displacement power factor	98% through speed range.
Motor control algorithm	Sensorless flux vector control with a pulse width modulated (PWM) output wave form.
DC injection braking	Automatic during stopping for 0.5 seconds after output frequency drops below 0.1 Hz.
Braking torque	30% of nominal motor torque without dynamic braking (typical value). Up to 150% with dynamic braking option. ^[1]
Transient output current	160% of nominal NEC rated motor current for 60 seconds.
Transient motor torque	200% of nominal motor torque (typical value at $\pm 10\%$) for 2 seconds. 170% of nominal motor torque (typical value at $\pm 10\%$) for 60 seconds.
Drive controller protection	Protection against short circuits: <ul style="list-style-type: none"> • between output phases • between output phases and ground • on outputs of internal power supplies Thermal protection against overheating and overcurrent. Undervoltage and overvoltage faults. Protection against single-phase input operation on the three-phase drive controllers.
Motor protection	Thermal protection integrated in the drive controller by continuous calculation of I^2t , taking motor speed into account. ^[2] Motor thermal state is retained during loss of power. Motor thermal protection can be modified with a programming option to correspond to the type of motor cooling. ^[1] Protection against motor phase loss. Protection by motor thermal sensors with optional analog I/O card. ^[1]
Codes and standards	UL Listed per UL 508C as incorporating electronic overload protection: UL File E164874 CCN NMMS CSA Certified CSA File LR96921 Class 3211-06

^[1] See Appendix A for a list of accessories.

^[2] Motor power rating must be between 25% minimum, 136% maximum, of drive controller rating.

DIMENSIONS AND WEIGHTS

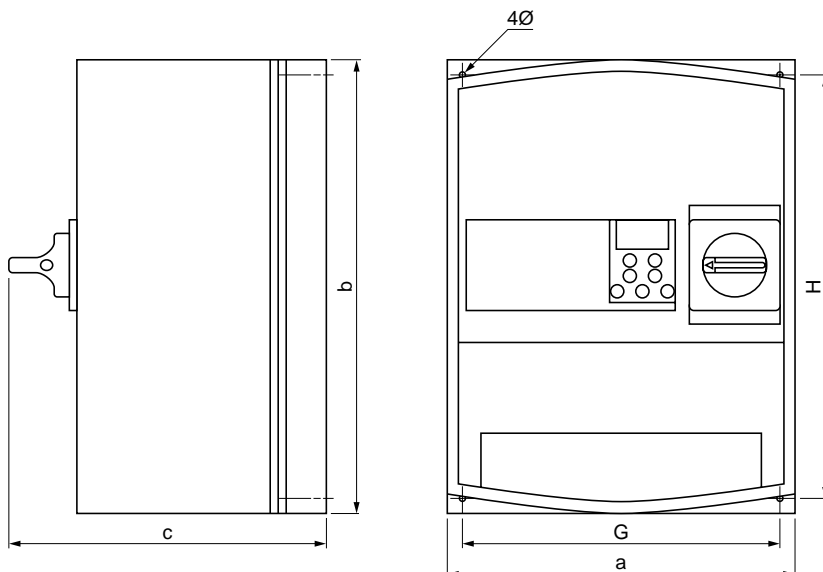

Figure 1: Dimensions

Catalog No. ATV58E.....	Product Frame Size	a in. (mm)	b in. (mm)	c in. (mm)	G in. (mm)	H in. (mm)	Ø in. (mm)	Weight lb (kg)
U09M2FZU, U18M2FZU	1	9.06 (230)	12.44 (316)	8.46 (215)	8.27 (210)	11.81 (300)	0.22 (5.5)	4.31 (9.5)
U29M2FZU, U18N4FZU, U29N4FZU, U41N4FZU	2	10.63 (270)	13.27 (337)	9.84 (250)	9.84 (250)	12.64 (321)	0.22 (5.5)	4.76 (10.5)
U41M2FZU, U54N4FZU, U72N4FZU, U90N4FZU	3	11.81 (300)	15.98 (406)	11.06 (281)	11.02 (280)	15.39 (391)	0.22 (5.5)	8.84 (19.5)

INSTALLATION PRECAUTIONS

Observe the following precautions when installing the ATV58 TRX Type F drive controller:

⚠ DANGER

HAZARDOUS VOLTAGE

Before servicing the drive controller:

- Disconnect all power supplying this equipment.
- Place a “DO NOT TURN ON” label on the disconnect supplying the drive controller.
- Lock the disconnect in open position.

Electrical shock will result in death or serious injury.

- Install a disconnect device on the input line side of the drive controller in accordance with national and local codes. **The manual motor control switch on the cover of the drive controller is not rated as a disconnect.**
- Verify that the voltage and frequency of the input line match the drive controller nameplate rating.
- Install the drive controller in an environment that does not exceed Type 12 limitations or the maximum drive ambient temperature rating.
- Do not place the drive controller near any heat generating sources. Do not mount it directly above another drive controller.
- Mount the drive controller on a flat, solid surface to achieve proper air flow through the heat sink fins.
 - Install the drive controller vertically, $\pm 10^\circ$, with the power terminals at the bottom.
 - Use bolts with washers to secure the drive controller.
 - Figure 2 shows the minimum clearances required above and below the drive controller for unobstructed airflow. Leave sufficient free space to ensure that the air required for cooling purposes can circulate from the bottom to the top of the drive controller.

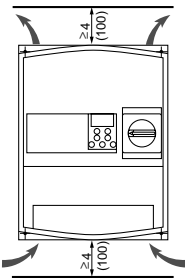

Figure 2: Minimum Clearances [in. (mm)]

BUS VOLTAGE MEASUREMENT PROCEDURE

⚠ DANGER

HAZARDOUS VOLTAGE

- Read and understand the bus voltage measurement procedure before performing procedure. Measurement of bus capacitor voltage must be performed by qualified personnel.
- DO NOT short across DC bus capacitors or touch unshielded components or terminal strip screw connections with voltage present.
- Many parts in this drive controller, including printed wiring boards, operate at line voltage. DO NOT TOUCH. Use only electrically insulated tools.

Electrical shock will result in death or serious injury.

The DC bus voltage level is determined by monitoring the (+) and (-) measurement points. Their location varies by drive controller model number as listed in Table 6 and shown in Figure 3 on page 14. The drive controller model number is listed on its nameplate.

Table 6: (+) and (-) Measurement Points

Drive Controller ATV58E*****	(+) Measurement Point		(-) Measurement Point	
	Terminal Block or Connector	Terminal Designation	Terminal Block or Connector	Terminal Designation
U09M2FZU and U18M2FZU	J2	(+)	J2	(-)
U29M2FZU to U41M2FZU	J2	PA	J18	7
U18N4FZU to U90N4FZU				

To measure the DC bus capacitor voltage:

1. Open the branch circuit disconnect means between the input line and the drive controller. Lock the disconnect means in the open position and install a “Do Not Turn On” sign. Also, be sure to remove external control power that may be present on the control board and the option board terminals.
2. Wait three minutes for the DC bus capacitors to discharge.

3. Read the model number of the drive controller from the nameplate and identify the corresponding (+) and (-) measurement points from Table 6 and Figure 3.
4. Remove the drive controller cover as illustrated on page 15.
5. Set the voltmeter to the 1000 Vdc scale. Measure the voltage between the (+) and (-) measurement points identified in step 4.
6. Verify that the DC bus voltage has discharged below 45 V before servicing the drive controller. If the DC bus capacitors will not discharge below 45 V, contact your local Square D representative. **Do not operate the drive controller.**
7. Replace all of the covers after servicing the drive controller.

The J18 connector is in the upper left hand corner of the main control board behind the flexible shield. Use a thin probe to access the connector pin.

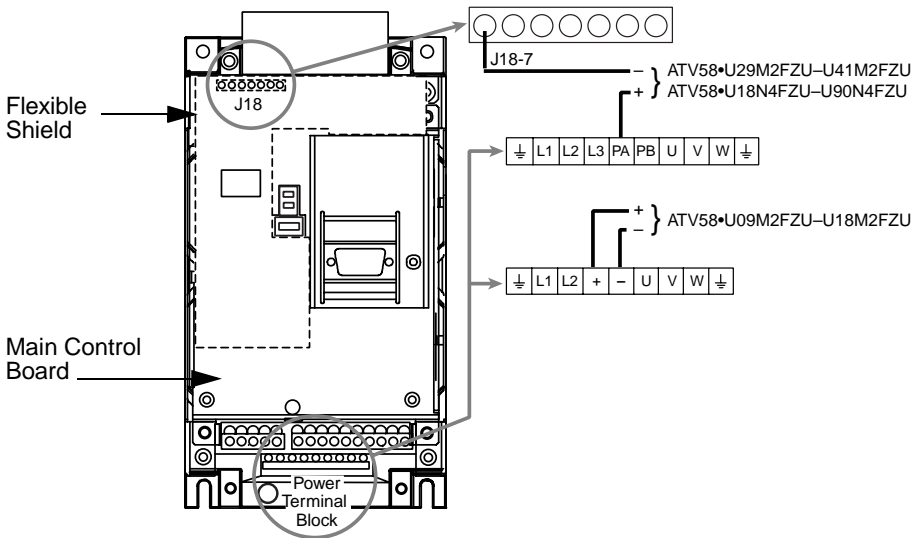
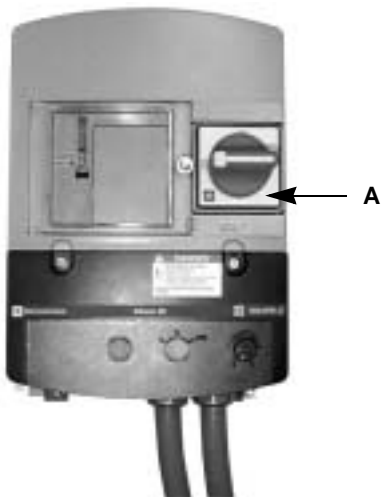

Figure 3: DC Bus Measurement Terminals (ATV58EU09M2FZU Chassis Shown)

Removing the Drive Controller Cover

NOTE: Perform steps 1–3 of the bus voltage measurement procedure beginning on page 13 before removing the drive controller cover.

1. To disengage the cover interlock, rotate the manual motor control switch on the front cover to the off position.



2. Remove the screws securing the terminal block cover.

A	Manual Motor Control Switch
B	Terminal Block Cover
C	Screws

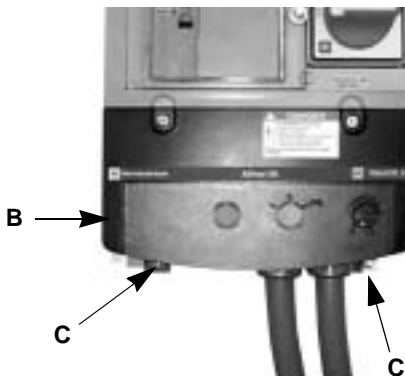

- Open all connections between the terminal block cover and the drive controller chassis including the option card if present. **For drive controllers ATV58EU09M2FZU and U18M2FZU**, proceed to step 5 on page 14 *unless you are installing an option card, then continue with step 4 below*. For all other drive controllers, continue with step 4 below.

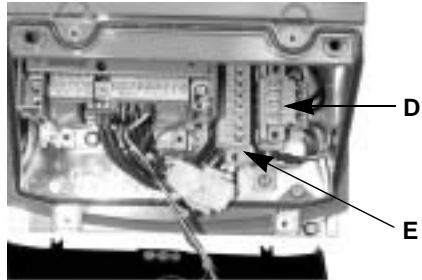

- Remove the screws securing the drive controller cover to the heat sink (**right**). Grasping the cover on the outside, pull it down and out of the way (**below**).

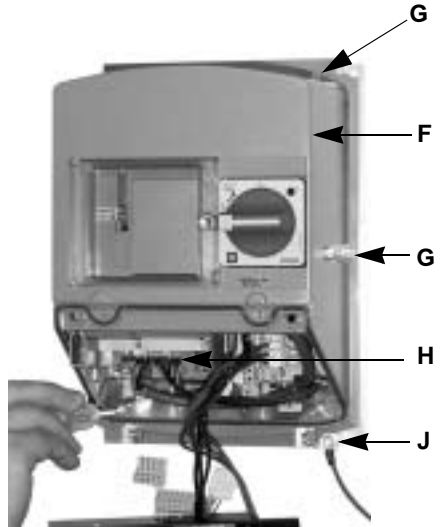

D	J2A Input Power Terminal Block
E	J2B Output Power Terminal Block
F	Drive Controller Cover
G	Screws
H	J2 Chassis Power Terminal Block
J	Ground Terminal

WIRING

Before servicing the drive controller, perform the bus voltage measurement procedure beginning on page 13 to verify that the DC voltage is less than 45 V.

General Wiring Practices

Good wiring practice requires the separation of control circuit wiring from all power wiring. Power wiring to the motor must have the maximum possible separation from all other power wiring, whether from the same drive controller or other drive controllers. **Do not run power and/or control or multiple power wiring in the same conduit.** This separation reduces the possibility of coupling electrical transients from power circuits into control circuits or from motor power wiring into other power circuits.

CAUTION

EQUIPMENT DAMAGE HAZARD

Follow wiring practices described in this document in addition to those already required by the National Electric Code and local electrical codes.

Failure to follow this instruction can result in injury or equipment damage.

Follow these practices when wiring ATV58 TRX Type F drive controllers:

- Use metallic conduit for all drive controller wiring. Do not run control and power wiring, or output power wiring from more than one drive controller, in the same conduit.
- Separate metallic conduits carrying power wiring or low-level control wiring by at least 3 in. (76 mm).
- Separate non-metallic conduits or cable trays used to carry power wiring from metallic conduit carrying low-level control wiring by at least 12 in. (305 mm).
- Whenever power and control wiring cross, the metallic conduits and non-metallic conduits or trays must cross at right angles.
- Equip all inductive circuits near the drive (relays, contactors, solenoid valves) with noise suppressors or connect them to a separate circuit.
- The ferrite core included with the terminal block cover is not required for North American installations.

Conduit Connections

The ATV58 TRX Type F controller is furnished with four conduit openings at the bottom for input and output power wiring, control wiring, and connection to external components such as DB resistors and line reactors. The holes are pre-drilled for the conduit recommended in Table 7 and are closed with Type 12-rated plugs. To maintain the Type 12 rating, do not remove the plugs from unused conduit holes.

When making conduit connections, use a 2 ft. minimum length of flexible conduit at the drive controller to facilitate removal of the terminal block cover.

Table 7: Recommended Conduit

Drive Controller Catalog No.	Conduit Hole Size	Recommended Conduit	Hub Catalog No.
ATV58EU09M2FZU ATV58EU18M2FZU	7/8 inch	1/2 inch	25211-16102
All other ATV58 TRX Type F Drive Controllers	13/32 inch	3/4 inch	25211-24102

Branch Circuit Connections

Refer to NEC Article 430 for sizing the branch circuit conductors. All branch circuit components and equipment (such as transformers, feeder cables, disconnect devices, and protective devices) must be rated for the input current of the drive controller, or the rated output current, whichever value is larger. The input current of the controller depends on the impedance of the power distribution system and the available short-circuit current at the drive input terminals.

Select the input current corresponding to the available short-circuit current capability or the line impedance present. If the available short-circuit current capability of the branch circuit is limited by fuses or circuit breakers (not system impedance), use the available short-circuit current capability on the line side of the fuses or circuit breakers to select the drive controller input current. The input current values for the variable torque drive controller ratings are based on nominal NEC rated motor currents. The input current values for the constant torque drive controller ratings are based on drive controller rated output currents. Tables 8 to 10 provide input current information to optimally size branch circuit conductors.

⚠ WARNING

IMPROPER CURRENT COORDINATION

- Protective devices must be properly coordinated.
- The National Electrical Code requires branch circuit protection. Use the fuses recommended in Tables 13 to 15 on page 28 of this manual to achieve published short-circuit current ratings.
- Do not connect the drive controller to a power feeder whose short-circuit capacity exceeds drive controller short-circuit current rating listed on drive controller nameplate or Tables 8 to 10.

Failure to follow this instruction can result in death, serious injury or equipment damage.

Table 8: Input Line Currents, 208/230 V Ratings, Single-Phase Input, Three-Phase Output

Drive Controller Catalog Number	Motor Power @ 4 kHz Switching Frequency		Rated Output Current A	Input Line Current					
				2000 Short-Circuit Current Rating		5000 Short-Circuit Current Rating		w/ Additional 3% Line Impedance	
				208 V A	230 V A	208 V A	230 V A	208 V A	230 V A
ATV58EU09M2FZU	0.37	0.5	2.3	5.6	4.7	—	—	4.2	3.8
ATV58EU18M2FZU	0.75	1	4.1	9.8	8.3	—	—	7.9	7.0
ATV58EU29M2FZU	1.5	2	7.8	—	—	18.5	15.6	14.1	12.3
ATV58EU41M2FZU	2.2	3	11	—	—	25.6	21.6	20.5	17.5

NOTE: The Input conductor ampacity rating should not be less than the ampacity rating selected based on the rated controller output current.

Table 9: Input Line Currents, 208/230 V Ratings, Three-Phase Input, Three-Phase Output

Drive Controller Catalog Number	Motor Power @ 4 kHz Switching Frequency		Rated Output Current A	Input Line Current			
				5000 Short-Circuit Current Rating		w/ Additional 3% Line Impedance	
				208 V A	230 V A	208 V A	230 V A
ATV58EU29M2FZU	1.5	2	7.8	9.7	8.3	6.6	5.9
ATV58EU41M2FZU	2.2	3	11	13.4	11.4	9.5	8.5

NOTE: The Input conductor ampacity rating should not be less than the ampacity rating selected based on the rated controller output current.

Table 10: Input Line Currents, 400/460 V Ratings, Three-Phase Input, Three-Phase Output

Drive Controller Catalog Number	Motor Power @ 4 kHz Switching Frequency		Rated Output Current A	Input Line Current			
	400 V kW	460 V hp		5000 Short-Circuit Current Rating		w/ Additional 3% Line Impedance	
				400 V A	460 V A	400 V A	460 V A
ATV58EU18N4FZU	0.75	1	2.3	3.4	2.6	1.9	1.6
ATV58EU29N4FZU	1.5	2	4.1	6.0	4.5	3.3	3.0
ATV58EU41N4FZU	2.2	3	5.8	7.8	6	4.8	4.2
ATV58EU54N4FZU	3	—	7.8	10.2	7.8	6.3	5.6
ATV58EU72N4FZU	4	5	10.5	13.0	10.1	8.6	7.2
ATV58EU90N4FZU	5.5	7.5	13	17.0	13.2	11.8	10.1

NOTE: The Input conductor ampacity rating should not be less than the ampacity rating selected based on the rated controller output current.

Output Wiring Precautions

⚠ WARNING
<p>DRIVE CONTROLLER DAMAGE</p> <p>The drive controller will be damaged if input line voltage is applied to output terminals (U, V, W). Check power connections before energizing the drive controller.</p> <p>Failure to follow this instruction can result in death, serious injury or equipment damage.</p>

The drive controller is sensitive to the amount of capacitance (either phase-to-phase or phase-to-ground) present on the output power conductors. If excessive capacitance is present, the drive controller may trip on overcurrent.

Follow the guidelines below when selecting output cable:

- Cable type: the cable selected must have a low capacitance phase-to-phase and to ground. Do not use mineral-impregnated cable because it has a very high capacitance. Immersion of cables in water increases capacitance.
- Cable length: the longer the cable, the greater the capacitance. Cable lengths greater than 100 ft (30.5 m) may affect controller and/or motor performance.

- Proximity to other output cables: because of high frequency switching and increased capacitance, the drive controller may fault under some conditions.
- **Do not use lightning arrestors and/or power factor correction capacitors on the output of the drive controller.**
- Provide at least 20 in. (500 mm) of cable at the drive controller output (U, V, W) for the minimum inductance needed to protect the drive controller output from short circuits.

⚠ CAUTION

DRIVE CONTROLLER SWITCH FAILURE

For proper drive controller short circuit protection, certain values of inductance may be required in the output power wiring. Inductance can be supplied by the power wiring or auxiliary inductors.

Failure to follow this instruction can result in injury or equipment damage.

Grounding

For safe, dependable operation, ground the drive controller according to National Electrical Code and all local codes. To ground the drive controller:

- Connect a copper wire from the ground terminal on the drive controller (see Item J on page 16) to the power system ground conductor. Wire size is determined by the drive controller size and by national and local codes.
- Verify that resistance to ground is one ohm or less. Improper grounding causes intermittent and unreliable operation.

⚠ DANGER

HAZARDOUS VOLTAGE

Ground equipment using provided ground connecting point as shown on page 16 (Item J). Drive controller panel must be properly grounded before power is applied.

Do not use metallic conduit as a ground conductor.

Electrical shock will result in death or serious injury.

Ground multiple drive controllers as shown in Figure 4. Use one grounding conductor per device. Do not loop ground conductors or install them in series.

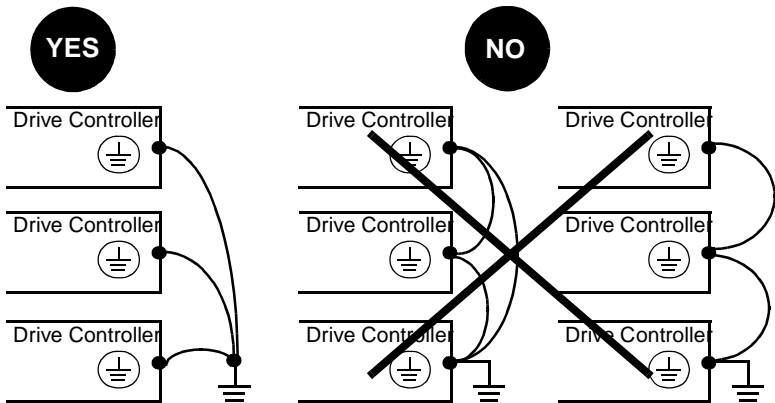
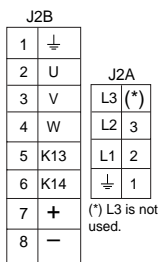
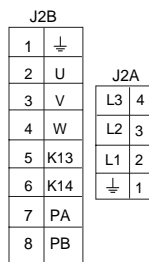

Figure 4: Grounding Multiple Drive Controllers

Power Terminals



ATV58EU09M2FZU and
U18M2FZU
(Single-phase input only)



All other ATV58 TRX Type F
drive controllers

Table 11: Function of Power Terminals

Terminal	Function	For ATV58E*****
⏏	Ground terminal	All models
L1 L2	Input connections to the drive	All models
L3		All models except U09M2FZU and U18M2FZU
+ -	Connection for optional DB module [1]	U09M2FZU and U18M2FZU
PA PB	Connection for optional DB resistor [1]	All models except U09M2FZU and U18M2FZU
K13 K14	Open terminals available for certain uses	All models
U V W	Output connections to motor	All models
⏏	Ground terminal	All models

[1] See Appendix A for a list of accessories.

Power Terminal Wire Size and Torque

For all ATV58 TRX Type F models, the maximum wire size is 10 AWG (4 mm²). The recommended torque is 5.0 lb-in (0.6 N•m). Use 75 °C copper wire.

Control Terminals

The control terminal strip contains two pull-apart terminal blocks, one for the relay outputs and one for the low level inputs and outputs. The S terminal is used for the shield connection. Maximum wire size for all control terminals is 14 AWG (1.5 mm²). The tightening torque is 3.5 lb-in (0.4 N•m). Figure 5 shows the location of the control terminals.

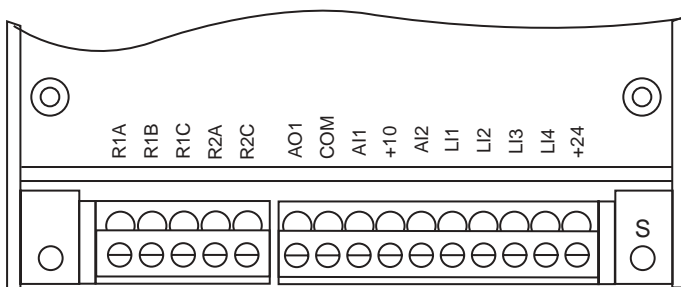

Figure 5: Location of Control Terminals

Table 12: Control Terminal Characteristics

Terminal	Function	Characteristics
S	Shield connection	
R1A R1B R1C	R1A to R1C is a N.O. contact. When the drive controller is powered with no fault, the contact is closed. R1B to R1C is a N.C. contact. When the drive controller is powered with no fault, the contact is open.	Minimum: 10 mA, 24 Vdc Maximum: inductive load of 1.5 A for 250 Vac and 30 Vdc Maximum resistive load: 5 A for 250 Vac or 30 Vdc
R2A R2C	N.O. programmable relay R2	
COM	Common for logic and analog inputs	
AO1 [1]	Analog current output X–Y mA analog output, with X and Y programmable from 0–20 mA. Factory setting: 0–20mA	Maximum load impedance = 500 Ω Resolution: 0.04 mA (9 bits) Linearity: +/- 0.1 mA Accuracy: +/- 0.2 mA The analog output is updated every 2mS, maximum

[1] AO1 is available only on controllers manufactured after August 2002.

Table 12: Control Terminal Characteristics (Continued)

Terminal	Function	Characteristics
AI1	Analog input 1 (voltage) Used for speed reference input	0 to 10 Vdc, Impedance = 30 kΩ Frequency resolution analog reference: high speed / 1024 Hz (10 bit). Accuracy ±1%, linearity ±0.5% of the maximum output frequency. Sampling time: 5 ms
+10	Supply for reference potentiometer (1 to 10 kΩ potentiometer)	10 V ± 1%, protected against short circuits and overloads 10 mA maximum
AI2	Analog input 2 (current) Used for speed reference input or feedback, depending on configuration.	X to Y mA, with X and Y programmable from 0 to 20 mA; Factory setting: 0 to 20 mA Impedance = 100 Ω Frequency resolution analog reference: high speed / 1024 Hz (10 bit). Accuracy ±1%, linearity ±0.5% of the maximum output frequency. Sampling time: 5 ms
LI1 LI2 LI3 LI4	Logic inputs Function depends on configuration. See Table 16 on page 33 for factory settings.	Supplied by +24 Vdc State 0 if < 5 V, state 1 if > 11 V Vmax = 30 V Impedance = 3.5 kΩ Sampling time: 5 ms
+24	Power supply for logic inputs	+24 V protected against short circuits and overloads Minimum 20 V, maximum 30 V 200 mA maximum

[1] AO1 is available only on controllers manufactured after August 2002.

WARNING

UNINTENDED EQUIPMENT OPERATION

LI1 has priority:

- If LI1 is closed while LI2 is active, the controller will respond to LI1.
- If the LI1 input is lost while LI2 is active, the controller will respond to LI2 and reverse directions.

The logic inputs must be programmed appropriately for the application to prevent the motor from spinning in an unintended direction.

Failure to follow this instruction can result in death or serious injury.

WIRING DIAGRAMS

Single-Phase Input

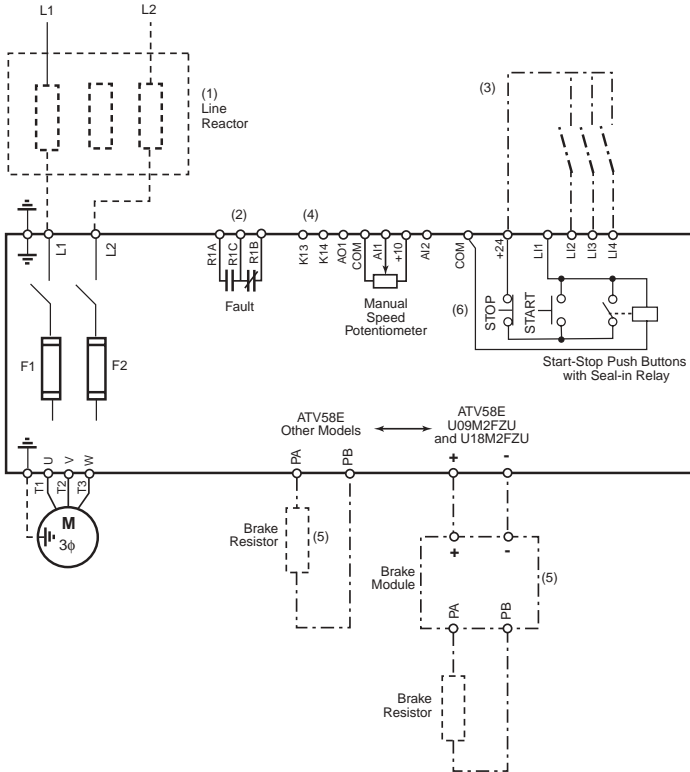

- (1) Line reactor if required.
- (2) Fault relay contacts for remote signalling of the drive controller state. Contact state is shown with the drive controller deenergized or faulted.
- (3) User installed wiring for using LI2, LI3, and LI4 with internal +24 V power supply. When using +24 V external supply, connect the 0 V to the COM terminal. Do not use the +24 V on the control board, but connect logic inputs to external +24 V. See Figure 8 on page 29.
- (4) K13 and K14 are open terminals available for customer use.
- (5) Use dynamic braking module VW3A58701 with drive controllers ATV58EU09M2FZU and U18M2FZU if dynamic braking is required. See Appendix A for the available braking resistor kits.
- (6) Manual speed potentiometer and start-stop push buttons are factory-installed in the enclosure cover. There is enough space in the cover to install one more 16-mm operator.

Figure 6: Single-Phase Wiring Diagram, 208/230 V Drive Controllers Only

Three-Phase Input

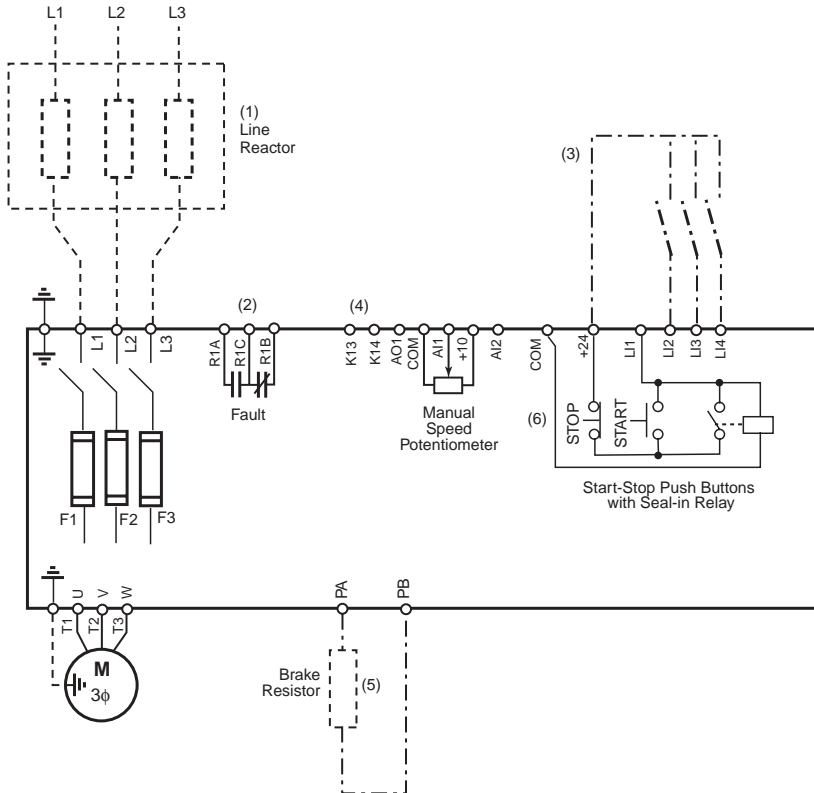

- (1) Line reactor if required.
- (2) Fault relay contacts for remote signalling of the drive controller state. Contact state is shown with the drive controller deenergized or faulted.
- (3) User installed wiring for using LI2, LI3, and LI4 with internal +24 V power supply. When using +24 V external supply, connect the 0 V to the COM terminal. Do not use the +24 V on the control board, but connect logic inputs to external +24 V. See Figure 8 on page 29.
- (4) K13 and K14 are open terminals available for customer use.
- (5) See Appendix A for the available braking resistor kits.
- (6) Manual speed potentiometer and start-stop push buttons are factory-installed in the enclosure cover. There is enough space in the cover to install one more 16-mm operator.

Figure 7: Three-Phase Wiring Diagram

RECOMMENDED POWER FUSES

Table 13: 208/230 V Single-Phase Drive Controllers

Motor		Drive Controller	F1, F2 Line Power Fuses
hp	kW	ATV58E*****	Class CC
0.5	0.37	U09M2FZU	10
1	0.75	U18M2FZU	15
2	1.5	U29M2FZU	30
3	2.2	U41M2FZU	30

Table 14: 208/230 V Three-Phase Drive Controllers

Motor		Drive Controller	F1, F2 Line Power Fuses
hp	kW	ATV58E*****	Class CC
2	1.5	U29M2FZU	15
3	2.2	U41M2FZU	20

Table 15: 400/460 V Three-Phase Drive Controllers

Motor		Drive Controller	F1, F2, F3 Line Power Fuses
hp	kW	ATV58E*****	Class CC
1	0.75	U18N4FZU	5
2	1.5	U29N4FZU	10
3	2.2	U41N4FZU	12
—	3	U54N4FZU	15
5	4	U72N4FZU	20
7.5	5.5	U90N4FZU	30

USING AN EXTERNAL LINE CONTACTOR

When controlling the power to the drive controller with an isolation line contactor, avoid frequently opening and closing the line contactor as this could cause premature failure of the drive controller. Use inputs LI1 to LI4 to start and stop the drive controller. **Limit operations of the line contactor to less than once per minute.**

EXTERNAL 24 V SUPPLY

An external 24 V power supply can be used for the logic inputs. In this case, the +24 terminal on the drive controller is not used. Figure 8 shows the wiring diagram when an external supply is used.

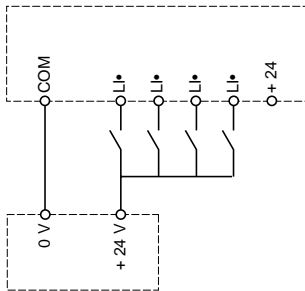

Figure 8: External Supply Wiring Diagram

FAULT RELAY

The fault relay is energized whenever there is power to the drive controller and there is no fault. It provides a normally-open and a normally-closed contact.

Drive controller reset after a fault is accomplished by cycling power, allowing the red fault LED to turn off.

INSTALLING THE OPTION CARDS

To install an optional I/O extension card or a communication card:

1. Follow the bus voltage measurement procedure on page 13.
2. Follow the installation directions in the instruction bulletin supplied with the option card. Refer to Figure 9.
3. Reinstall the drive controller cover.

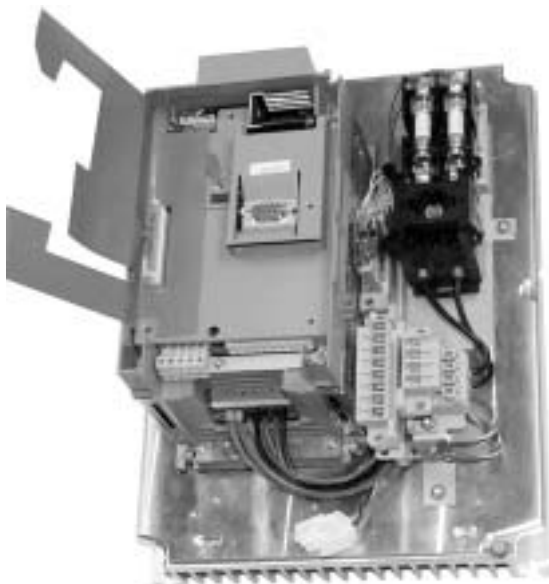

Figure 9: Installing an Option Card

INSTALLING THE COMMUNICATION CABLES

Communication cables can be routed through the terminal block cover. Refer to Figure 10 for cable routing instructions.

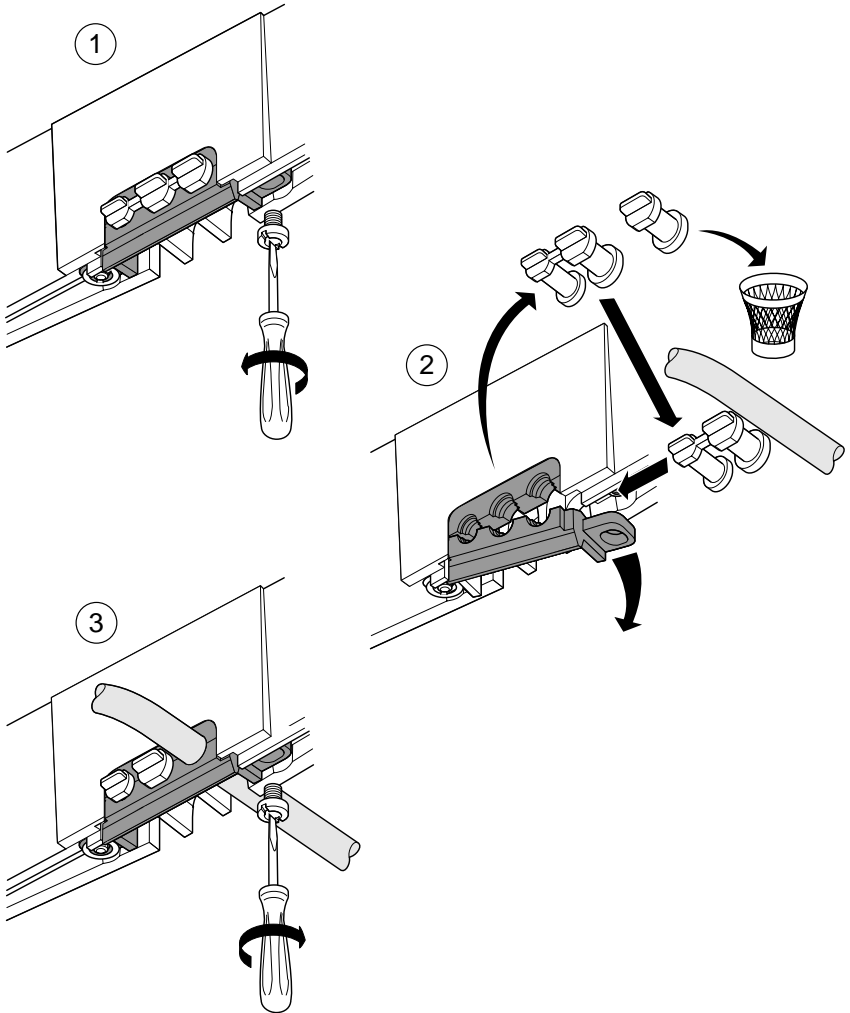

Figure 10: Routing the Communication Cables Through the Terminal Block Cover

AVAILABLE MOTOR TORQUE

Continuous duty:

- For self-ventilated motors, motor cooling depends on the speed.
- Continuous duty results in derating for speeds less than 50% of the nameplate motor speed.

Operation in overspeed:

- In overspeed operation, the voltage no longer increases with the frequency, resulting in reduced induction in the motor which translates into a loss of torque. Consult the motor manufacturer to ensure that the motor can operate in overspeed.
- For a special motor, the nominal frequency and the maximum frequency can be adjusted between 40 and 500 Hz using the keypad display, programming terminal, or test & commissioning software. See Appendix A for a list of accessories.

CAUTION

MACHINERY OVERSPEED

Some motors and/or loads may not be suited for operation above the nameplate motor speed and frequency. Consult the motor manufacturer before operating the motor above the rated speed.

Failure to follow this instruction can result in injury or equipment damage.

The available overtorque is a function of the motor design category. For typical NEMA Design B motors, the ATV58 TRX controller can deliver 200% of the nominal motor torque for 2 seconds, and 170% for 60 seconds.

Motor power rating must be at least 25% of drive rated power for the drive controller to properly operate the motor.

Figure 11 on page 33 shows the typical torque characteristics of a standard motor powered by the ATV58 TRX drive controller.

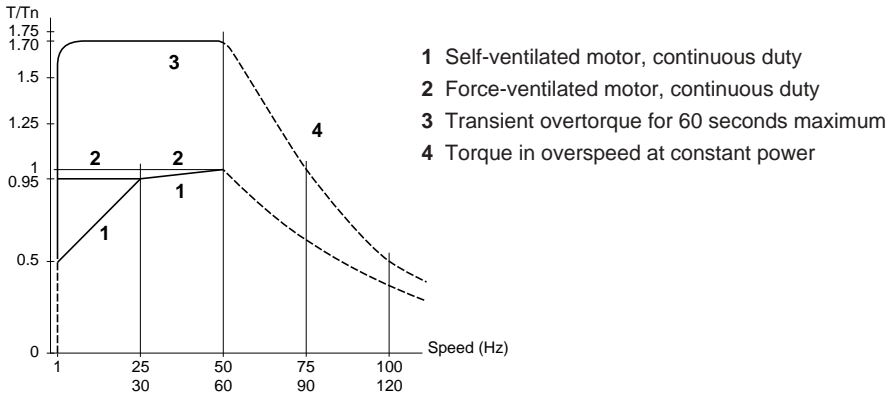

Figure 11: Typical Torque Characteristics

FACTORY SETTINGS

The ATV58 TRX Type F drive controller is preset for constant torque applications. Table 16 lists the factory settings. See Appendix A for available configuration tools to alter factory settings.

Table 16: Factory Settings

Function	Setting
Base frequency	50 or 60 Hz ^[1]
Motor voltage	240 V or 400/460 V, depending on model. See Figure 12 on page 36.
Acceleration and deceleration ramps	3 s
Low speed	0 Hz
High speed	50/60 Hz ^[1]
Maximum frequency	60/72 Hz ^[1]
Motor thermal current	0.9 times rated drive controller output current
DC braking current at stop	0.63 times rated drive controller output current for 0.5 s
Operation	Constant torque
Control type	2-wire control

^[1] Depending on the position of the 50/60 Hz switch. Factory set to 60 Hz (72 Hz maximum frequency). See page 33.

Table 16: Factory Settings (Continued)

Function	Setting
Logic inputs	LI1: Run Forward; LI2: Run Reverse
	LI3 LI4 Preset speed
	0 0 Low speed + reference
	1 0 10 Hz
	0 1 15 Hz
1 1 High speed	
Analog inputs	AI1: 0 to +10 V speed reference AI2: 4 to 20 mA speed reference Speed references at AI1 and AI2 are summed together.
Analog output	Motor frequency
Relay outputs	R1: fault relay (cannot be reassigned) R2: not assigned (can be reassigned)
Switching frequency	4 kHz
^[1] Depending on the position of the 50/60 Hz switch. Factory set to 60 Hz (72 Hz maximum frequency). See page 33.	

START UP

DANGER

HAZARDOUS VOLTAGE

- Read and understand this bulletin in its entirety before installing or operating ALTIVAR 58 TRX drive controllers. Installation, adjustment, repair, and maintenance of the drive controllers must be performed by qualified personnel.
- The user is responsible for conforming to all applicable code requirements with respect to grounding all equipment.
- Many parts in this drive controller, including printed wiring boards, operate at line voltage. **DO NOT TOUCH.** Use only electrically insulated tools.
- **DO NOT** short across DC bus capacitors or touch unshielded components or terminal strip screw connections with voltage present.
- Before servicing the drive controller:
 - Disconnect all power including external control power that may be present before servicing the drive controller.
 - Place a “DO NOT TURN ON” label on the drive controller disconnect.
 - Lock the disconnect in open position.
 - **WAIT THREE MINUTES** for the DC bus capacitors to discharge. Then follow the DC bus voltage measurement procedure on page 13 to verify that the DC voltage is less than 45 V. The drive controller LEDs are not accurate indicators of the absence of DC bus voltage.
- Install and close all covers before applying power or starting and stopping the drive controller.

Electrical shock will result in death or serious injury.

Before powering up the drive controller, set the 50/60 Hz switch to correspond with the incoming power frequency. The 50/60 Hz switch is on the control board. To access it, unlatch and open the clear plexiglass door to the left of the manual motor control switch (see Figure 12). If an option card is present, the switch will still be accessible through the card. Set the switch to the position corresponding to the mains frequency.

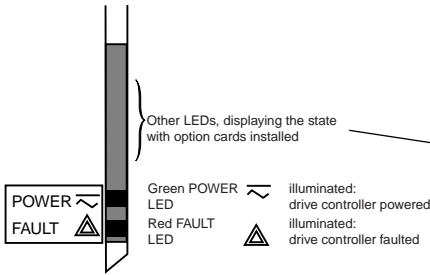

Drive controller shown with optional keypad.

The pre-adjusted operating voltage corresponding to the switch position is:

- 50 Hz Position:
 -240 V, 50 Hz for ATV58E***M2
 -400 V, 50 Hz for ATV58E***N4
- 60 Hz Position (Factory Setting):
 -240 V, 60 Hz for ATV58E***M2
 -460 V, 60 Hz for ATV58E***N4

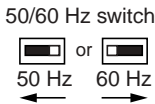

Figure 12: Setting the 50/60 Hz Switch/LED States

Several tools are available to aid in starting up the ATV58 TRX Type F drive controller:

- Keypad display, VW3A58101U. The drive controller is shipped without the keypad display.
- Test and Commissioning software, VW3A8104, ordered separately

Consult the documentation provided with each of these tools to start up and maintain the drive controller. If your drive controller has an I/O extension card or communication card, also consult the documentation provided with the option.

LIGHT EMITTING DIODES (LEDS)

The LEDs on the front of the drive controller indicate several states as shown in Figure 12 on page 36.

PREVENTIVE MAINTENANCE

To maintain your drive controller, at regular intervals:

- Check the condition and tightness of the connections.
- Make sure the ventilation is effective and that the temperature around the drive controller remains at an acceptable level.
- Remove dust and debris from the drive controller, if necessary.

TROUBLESHOOTING AND MAINTENANCE

When a fault is detected, the drive controller trips and the fault relay deenergizes.

After performing the “Bus Voltage Measurement Procedure” on page 13, check the supply voltage (Procedure 1 on page 37) and the peripheral components (Procedure 2 on page 38).

If no problem is found with the supply voltage and peripheral equipment, install a keypad display (VW3A58101U) for additional fault information. The faults are identified in the keypad display manual, VVDED397047US.

Refer to Appendix B on page 42 for internal wiring diagrams to assist with troubleshooting and maintaining internal components.

Procedure 1: Checking Supply Voltage

To determine if the voltage is within the drive controller tolerance:

1. Perform the Bus Voltage Measurement procedure (see “Bus Voltage Measurement Procedure” on page 13).
2. Attach meter leads to L1 and L2 on the J2A terminal block. Set the voltmeter to the 1000 Vac scale.
3. Reapply power and check for the correct line voltage, shown on the drive controller nameplate rating.
4. On drive controllers with three-phase input power, remove power and repeat the procedure for L2 and L3, and L1 and L3.
5. When all phases have been measured, remove power. Remove leads and replace all covers.

Procedure 2: Checking the Peripheral Equipment

The following equipment may need to be checked. Follow the manufacturers' procedures when checking this equipment.

1. A protective device such as fuses or circuit breaker may have tripped.
2. A switching device such as a contactor may not be closing at the correct time.
3. Conductors may require repair or replacement.
4. Connection cables to the motor or high resistance connections to ground may need to be checked. Follow NEMA standard procedure WC-53.
5. Motor insulation may need to be checked. Follow NEMA standard procedure MG-1. Do not apply high voltage to U, V, or W. Do not connect the high potential dielectric test equipment or insulation resistance tester to the drive controller since the test voltages used may damage the drive controller. Always disconnect the drive controller from the conductors or motor while performing such tests.

CAUTION

EQUIPMENT DAMAGE HAZARD

Do not perform high potential dielectric tests on circuits while the circuits are connected to the drive controller.

Any circuit requiring high potential dielectric tests must be disconnected from the drive controller prior to performing the test.

Failure to follow this instruction can result in injury or equipment damage.

Fault Storage

The first fault detected is saved and displayed on the optional keypad (VW3A58101U) if power is maintained. The drive controller trips and the fault relay opens.

To reset the fault:

1. Remove power from the drive controller.
2. Before switching power back on, identify and correct the cause of the fault.
3. Restore power. This will reset the fault when it has been corrected.

In certain cases, when automatic restart has been enabled, the drive can be automatically restarted after the cause of the fault has disappeared.

The Test & Commissioning software can be used to view the last eight faults recorded by the drive controller. See Appendix A for the part number.

APPENDIX A: OPTIONS AND ACCESSORIES

Table 17 shows the accessories available for ATV58 TRX drive controllers. See Appendix B for the repair parts list.

Table 17: ATV58 TRX Type F Drive Controller Accessories

Catalog No.	Description
VW3A8104	POWERSUITE™ Test & Commissioning Software on CD for use with Microsoft® WINDOWS 95, 98, and NT™ and Windows CE v3.0 for Pocket PCs
VW3A8106	PC Connection Kit for connecting the PC to an ATV58 TRX controller. Kit includes: 1 m cable with RJ45 connectors; RS-232 to RS-485 adapter with RJ45 and DB9 female connectors; RJ45 to DB9 adapter for use with an ATV58 controller; and cable adapter for use with an ATV11 controller.
VW3A8111	Pocket PC Connection Kit for connecting a JORNADA PPC to an ATV58 TRX controller. Kit includes: 1/2 m cable with RJ45 connectors, RS-232 to RS-485 adapter with RJ45 and DB9 male connectors; RJ45 to DB9 adapter, cable adapter for use with an ATV11 controller, cable to connect the serial port on the PPC to the DB9 connector on the RS-232 to RS-485 adapter.
VW3A58101U	Keypad Display
VW3A58201U	Analog I/O Option Card
VW3A58202U	Digital I/O Option Card
VW3A58210U	Pump Switching Card
VW3A58253U	General Purpose Option Card
VW3A58301U	FIPIO® Communication Card
VW3A58302U	MODBUS® Plus Communication Card
VW3A58303U	MODBUS/UNITELWAY™ Communication Card
VW3A58304EU	Interbus S Communication Card. Requires external power supply.
VW3A58306U	RS-485 Cable w/ MODBUS Mapping Guide
VW3A58307U	Profibus DP Communication Card
VW3A58309U	DeviceNet™ Communication Card
VW3A58310U	Ethernet MODBUS TCP/IP Communication Card
VW3A58312PU	LONWORKS® to MODBUS DIN Rail Mount Gateway
VW3A58354U	JOHNSON CONTROLS® N2 Communication Card
VW3A58701	DB Transistor Module for ATV58EU09M2FZU and U18M2FZU
VW3A66711	DB Resistor Kit for ATV58EU09M2FZU, U18M2FZU, U18M2FZU
VW3A66712	DB Resistor Kit for ATV58EU29M2FZU, U41M2FZU, U90N4FZU

APPENDIX B: REPAIR PARTS

The following table shows the replacement parts available for ATV58 TRX Type F drive controllers

Catalog No.	Description
VW3A58866	Replacement speed potentiometer
VW3A58861	Replacement power terminal
VW3A58865	Sub-D cable entry
VX4A581U	ATV58 TRX control board kit
VZ3N581U	ATV58 TRX removable control board terminal strips (includes 9-position and 10-position relay terminal strip)
VW3A58821	Fan kit for ATV58EU09M2 and U18M2
VW3A58822	Fan kit for ATV58EU29M2, U41M2, and U18N4 to U41N4
VW3A58823	Fan kit for ATV58EU54M2, U72M2, and U54N4 to U90N4
VZ3V58223U	Internal fan kit (two fans) for ATV58EU41M2
1REL002511	Replacement seal-in relay

Factory repaired ATV58 TRX Type F drive controllers are available within 24 hours from a factory exchange pool, or your drive controller can be factory repaired and returned. Contact your local Square D Distributor or Square D Customer Service Representative at 919-266-8600 for availability.

APPENDIX C: INTERNAL WIRING

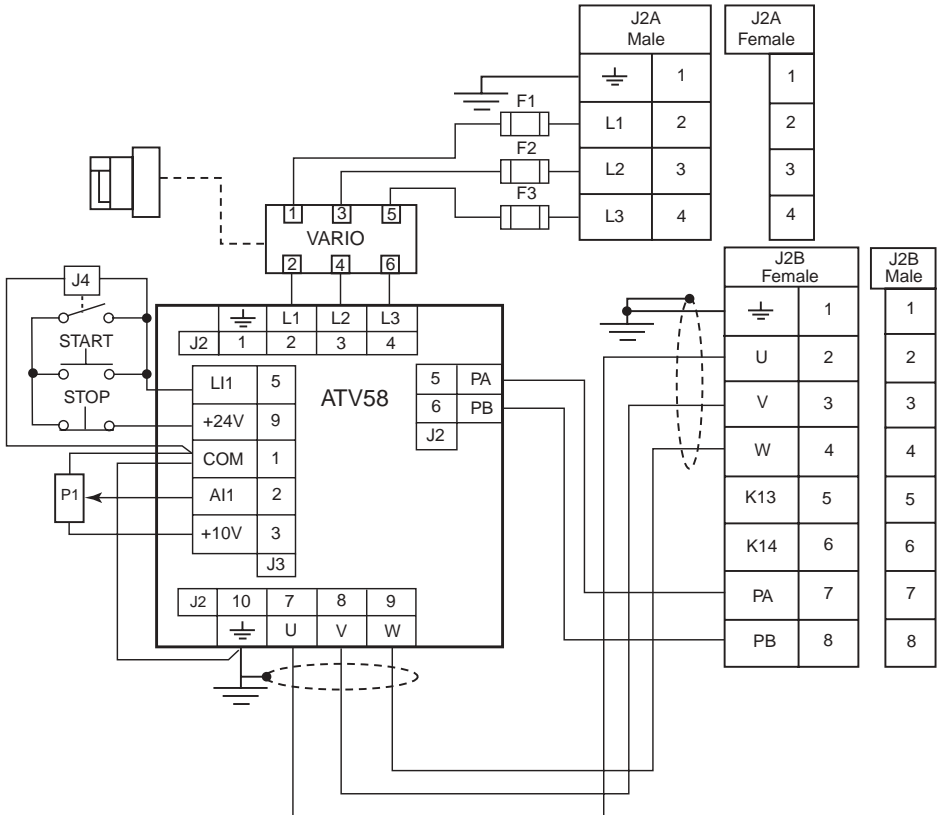

- ATV58: AC drive chassis
- VARIO: Manual motor control switch
- Start-stop push buttons: 16 mm devices
- J2A: Input power plug-in terminal
- J2B: Output power plug-in terminal
- J1: Left-most control plug-in terminal on AC drive chassis
- J2: Power terminal on AC drive chassis
- J3: Right-most control plug-in terminal on AC drive chassis
- J4: Seal-in Relay
- P1: Manual speed potentiometer

**Figure 13: Internal Wiring Diagram for all ATV58 TRX Controllers Except
 ATV58EU09M2FZU and ATV58EU18M2FZU**

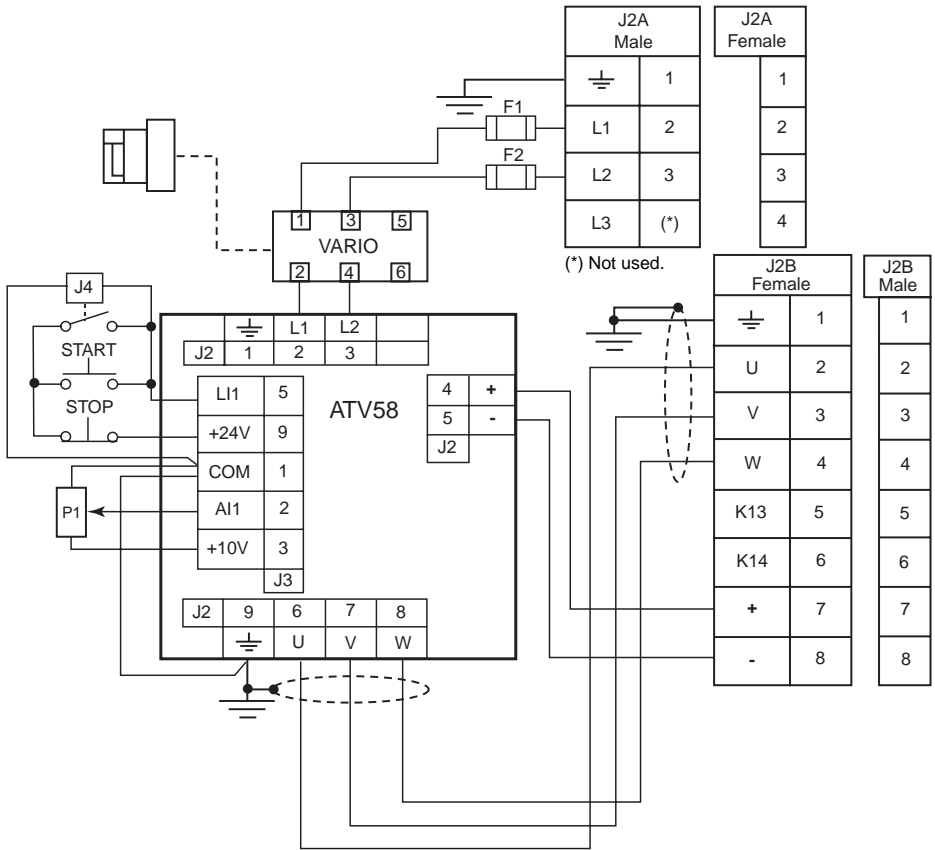

- ATV58: AC drive chassis
- VARIO: Manual motor control switch
- Start-stop push buttons: 16 mm devices
- J2A: Input power plug-in terminal
- J2B: Output power plug-in terminal
- J1: Left-most control plug-in terminal on AC drive chassis
- J2: Power terminal on AC drive chassis
- J3: Right-most control plug-in terminal on AC drive chassis
- J4: Seal-in Relay
- P1: Manual speed potentiometer

Figure 14: Internal Wiring Diagram for ALTIVAR 58 TRX Type F Drive Controllers, Model Numbers ATV58EU09M2FZU and ATV58EU18M2FZU

Numerics

50/60 Hz switch 36

A

acceleration ramp 33
AIC 19
altitude 9
ambient temperature 9
analog inputs 25, 34
analog output 34
automatic restart 39

B

bus voltage measurement 13

C

cable capacitance 20
cable length 20
cable type 20
codes and standards 10
communication cables 31
conduit 17, 18, 22
 size 18
constant torque 33
control type 33
current
 braking 33
 input 18
 maximum thermal 33
 output transient 10
 short circuit (AIC) 19

D

DC injection braking 10
deceleration ramp 33
dimensions 11
displacement power factor 10
dynamic braking connection
 23, 26, 27

E

efficiency 10
enclosure type 9
ethernet 5
external power supply 29

F

factory settings 33
fault relay. See relays
faults
 resetting 38
 storage 38
ferrite core 17
frequency
 input 9
 maximum 33
 output 9
 switching. See switching
 frequency
fuses 19
 line power 28

G

grounding 21

I

installation 12

K

keypad display 32, 36

L

LEDs 36, 37
lightning arrestors 21
line contactor, external 29
logic inputs 25, 29, 34

M

maintenance 37
manual motor control switch
 12, 15
minimum clearances 12
motor control algorithm 10
motor torque 32
motors
 self-ventilated 32
 special 32

O

operating position 9
option card installation 30
options 40
overspeed operation 32

P

peripheral equipment
 checking 38
pollution degree 9, 12
potentiometer 25
power factor correction
 capacitors 21
power supply, external 29
programming terminal 32
protection
 drive controller 10
 motor 10
 thermal 10

R

range 5
ratings
 200 to 240 V controllers 7, 19
 400 to 460 V controllers 8, 20
reactors 7, 26, 27
receiving 6
recommended equipment
 200/240 V controllers 28
 400/460 V controllers 28
relay outputs 34
relays 17, 24
 drive run 26, 27
 fault 29
 K13/K14 26, 27

S

shield connection 24
shipping 6
short-circuit current 19

specifications
 electrical 9
 environmental 9
speed range 9
speed regulation 10
start up 35
storing 6
supply voltage
 checking 37
switching frequency 9, 34

T

terminals
 control 24
 power 23
test & commissioning software
 32, 36, 39
torque
 available motor 32
 braking 10
 transient motor 10
transparent ready 5
troubleshooting 37

V

ventilation 37
vibration 9
voltage
 input 9
 output 9

W

weights 11
wiring

branch circuit components
 18
control 17
diagrams 26–27
external 24 V supply 29
general practices 17
internal 42, 43
minimum inductance 21
output 20
power 17
single phase input 26
three phase input 27

W915982160111A03

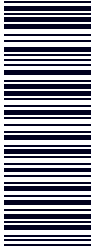

91598216011103

Square D Company
8001 Hwy 64 East
Knightdale, NC 27545 USA
1-888-SquareD (778-2733)
www.squared.com

Electrical equipment should be installed, operated, serviced, and maintained only by qualified personnel. No responsibility is assumed by Schneider Electric for any consequences arising out of the use of this material.

Bulletin No. VVDED300011USR2/03
© 2000–2003 Schneider Electric All Rights Reserved.
Replaces VVDED300011US dated January 2000.